

HOME PHILOSOPHY  
**visionnaire**

THE ORIGINAL ONE, DREAMED AND CRAFTED IN ITALY

**RESPIRO**









## B R E A T H

---

*space is the breath of art*

*Synonymous with renewal and transformation, "Breath" is the direction that strongly characterises the new Visionnaire style. The careful search for balance between material and shape, past and contemporaneity, leads immediately to symbolic and meditative places. Full then empty like diaphragms that oxygenate the surrounding space and that find their expression and preciousness in metal, wooden material and marble, as in stone, leather, wool and raffia, and bring a sensation of nature in harmonious arrangement, devoid of redundancy. Craftsanship is the value on which Visionnaire continues to focus its efforts to stand out: products with technical content summarised in style with strong personality. If Italy has always represented the inspiring element for the collections, from history of art, to cinema and the visual arts in general, then this year the creative direction looks on with a wise and refined mix, also to the East. The colour palette draws on tones from the earth and forests, rendering the natural element the true protagonist. A luxury proposal, therefore, that no longer only coincides with the object of merit, but which finds, in the multi-sensory atmosphere, in well-being, in imaginative strength and conviviality, the response to the evolution of a market in continuous transformation.*



## R E S P I R O

---

*lo spazio è il respiro dell'arte*

Sinonimo di rinnovamento e trasformazione, è il “Respiro” la direzione che fortemente caratterizza il linguaggio di Visionnaire. L’attenta ricerca di equilibrio tra materia e forma, tra passato e contemporaneità riportano immediatamente ad ambienti simbolici e meditativi. Pieni e vuoti come diaframmi che ossigenano lo spazio circostante e che trovano la loro espressione e preziosità nei metalli, nelle essenze legnose, nei marmi, così come nella pietra, nel cuoio, nelle lane e nelle raffie ed introducono ad una sensazione di natura in un accordo armonico, privo di ridondanza. L’artigianalità è il valore su cui Visionnaire continua a puntare per distinguersi: prodotti con contenuto tecnico, sintetizzati in un linguaggio di forte personalità. E se da sempre l’Italia ha rappresentato l’elemento ispiratore per le collezioni, dalla storia dell’arte, al cinema, alle arti visive in generale, quest’anno la direzione creativa guarda con un sapiente e raffinato mix, anche ad Oriente. La palette cromatica attinge alle tonalità dei colori della terra e delle foreste rendendo così l’elemento naturale, il vero protagonista. Una proposta lusso quindi che non coincide più esclusivamente al solo oggetto di pregio, ma che trova nell’ambiente multisensoriale, nel benessere, nella forza immaginativa e nella convivialità, la risposta all’evoluzione di un mercato in continua trasformazione.



# I N D E X

---

## *collection*

### **XAVIER**

divano componibile_ <i>modular sofa</i>	6
divano_ <i>sofa</i>	16

### **RYLAN**

tavolo basso_ <i>low table</i>	24
--------------------------------	----

### **DANNY**

mobile basso_ <i>low cabinet</i>	26
consolle_ <i>console</i>	29

### **KALGAN-BILBO-KAEL**

plafoniere_ <i>ceiling lamps</i>	32
----------------------------------	----

### **KERWAN**

tavolo da pranzo_ <i>dining table</i>	36
---------------------------------------	----

### **ASTRID**

sedia_ <i>chair</i>	42
---------------------	----

### **EKOS**

panca_ <i>bench</i>	44
consolle_ <i>console</i>	46

### **THAMOS**

mobile con ante_ <i>cabinet</i>	48
---------------------------------	----

### **AKIRA**

lampadario_ <i>chandelier</i>	52
applique_ <i>wall lamp</i>	55
lampada da tavolo_ <i>table lamp</i>	56
applique_ <i>wall lamp</i>	97

### **KATHRYN OUTDOOR**

poltroncina outdoor_ <i>outdoor armchair</i>	58
pouf outdoor_ <i>outdoor pouffe</i>	60

### **LUKE OUTDOOR**

lampada da terra_ <i>outdoor floor lamp</i>	63
---	----

### **RÊVERIE**

letto_ <i>bed</i>	64
-------------------	----

### **NOMOS**

comodino_ <i>bedside table</i>	70
cassettiera_ <i>chest of drawers</i>	72
mobile alto_ <i>cabinet</i>	108
mobile bar_ <i>bar cabinet</i>	114

### **RUPERT**

tavolo basso_ <i>low table</i>	76
--------------------------------	----

### **TANYA**

poltroncina_ <i>armchair</i>	80
sedia_ <i>chair</i>	106

### **MILO**

specchiera_ <i>mirror</i>	82
---------------------------	----

### **ANTHAR**

divano_ <i>sofa</i>	84
dormeuse	88

### **KOBOL**

consolle lavabo_ <i>console with basin</i>	92
specchio_ <i>mirror</i>	92
portasciugamani_ <i>towel holder</i>	92



# I N D E X

---

## *collection*

<b>JASON</b>			
tavolo da pranzo_ <i>dining table</i>	98		
<b>SYLAR</b>			
plafoniera_ <i>ceiling lamp</i>	118		
<b>TAYLOR</b>			
divano componibile_ <i>modular sofa</i>	120		
divano_ <i>sofa</i>	126		
<b>MIKA</b>			
poltroncina_ <i>armchair</i>	134		
<b>MARTY</b>			
consolle_ <i>console</i>	138		
tavolo basso_ <i>low table</i>	142		
<b>BRONSON</b>			
mobile basso_ <i>low cabinet</i>	144		
<b>GAIUS</b>			
mobile bar_ <i>bar cabinet</i>	150		
<b>RIPLEY</b>			
letto_ <i>bed</i>	154		
<b>LEGEND</b>			
poltrona_ <i>armchair</i>	160		
<b>JASPER</b>			
lampada da tavolo_ <i>table lamp</i>	162		
<b>BARNEY</b>			
cassettiera_ <i>chest of drawers</i>	164		
<b>ANASTASIA</b>			
poltroncina_ <i>armchair</i>		168	
poltrona_ <i>armchair</i>		172	
sedia_ <i>chair</i>		173	
<b>BACKSTAGE</b>			
divano componibile_ <i>modular sofa</i>		174	
divano_ <i>sofa</i>		182	
<b>BANNER</b>			
tavolo basso_ <i>low table</i>		190	
consolle_ <i>console</i>		192	
<b>PARKER</b>			
mobile basso_ <i>low cabinet</i>		194	
<b>OMEGA</b>			
lampada da tavolo_ <i>table lamp</i>		198	
<b>POLIDORO</b>			
specchiera_ <i>mirror</i>		200	
<b>BALANCE</b>			
divano_ <i>sofa</i>		202	
poltrona_ <i>armchair</i>		210	
<b>ASTRA</b>			
lampada da tavolo_ <i>table lamp</i>		212	
<b>BALIN-ELMO</b>			
<b>GALDOR-TAREG</b>			
specchio_ <i>mirror</i>		214	







**X A V I E R**  
**M A S T E R   &   B O A R D**

---

*modular sofa*









visionnaire





**XAVIER**

divano componibile\_modular sofa







XAVIER MASTER - sectional

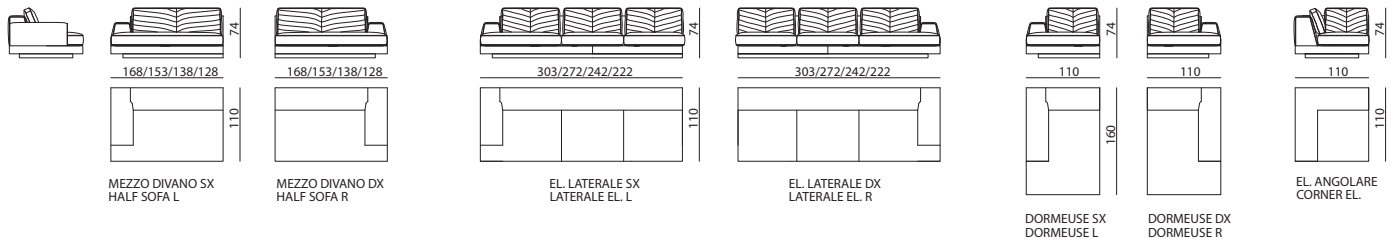

## XAVIER

divano componibile\_modular sofa  
design Mauro Lipparini

Divano componibile tappezzato in pelle o tessuto, con base a piattaforma e schienale e braccioli trapezoidali imbottiti, scocca interna in legno massello e multistrati di pioppo e faggio. Cuscini di seduta in poliuretano, memory foam® e piuma. Cuscini di schienale con lavorazione “chevron” in poliuretano e piuma. Disponibile anche con bracciolo e schienale in versione “board” in legno rivestito in pelle, tessuto o pelle intrecciata con elementi strutturali e decorativi in ottone massiccio satinato con placche incise con logo Visionnaire, cuscini schienale in diverse misure in poliuretano e piuma. Gli elementi laterali “board” sono disponibili anche con piattaforma estesa “extension” sotto il bracciolo di + 24 cm.

*Upholstered leather or fabric modular sofa, with platform base and backrest and trapezoidal upholstered armrests, inner shell in solid wood and poplar and beech plywood. Seat cushions in polyurethane, memory foam® and feather. Back cushions with “chevron” processing in polyurethane and feather. Also available with armrest and backrest in the “board” version in wood upholstered in leather, fabric or woven leather with structural and decorative elements in solid satin brass with engraved plaques with Visionnaire logo, backrest cushions in different sizes in polyurethane and feather. The side “board” elements are also available with optional “extension” platform under the armrest of + 24 cm.*





XAVIER BOARD - sectional

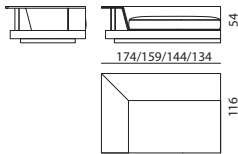

MEZZO DIVANO SX  
HALF SOFA L

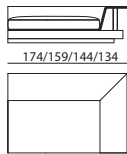

MEZZO DIVANO DX  
HALF SOFA R

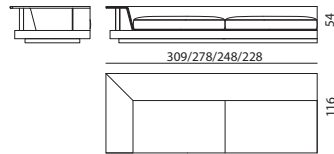

EL. LATERALE SX  
LATERALE EL. L

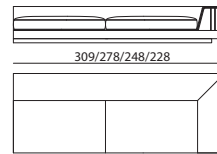

EL. LATERALE DX  
LATERALE EL. R

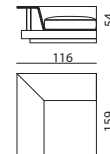

DORMEUSE SX  
DORMEUSE L

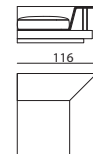

DORMEUSE DX  
DORMEUSE R

XAVIER BOARD - sectional with extension

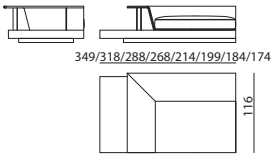

EL. LATERALE SX  
LATERALE EL. L

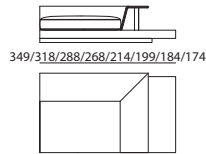

EL. LATERALE DX  
LATERALE EL. R





**X A V I E R M A S T E R**

---

*sofa*











**XAVIER**  
divano\_sofa



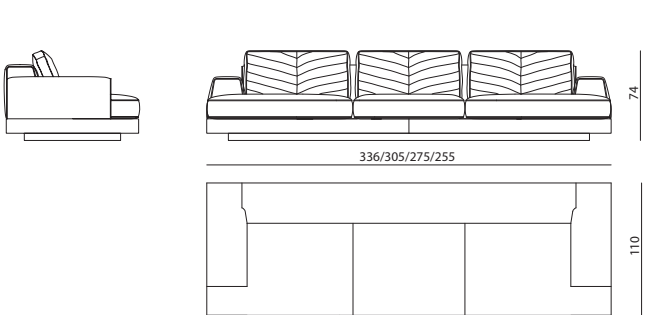

XAVIER MASTER - sectional

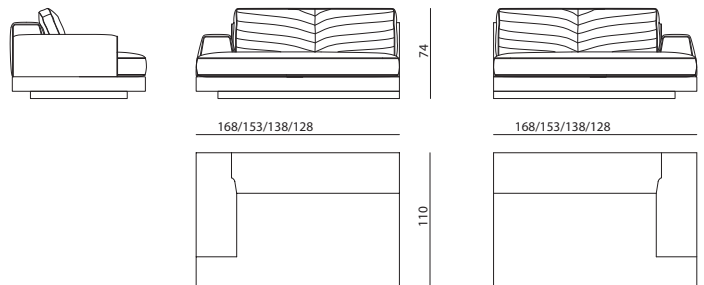

MEZZO DIVANO SX  
HALF SOFA L

MEZZO DIVANO DX  
HALF SOFA R



## XAVIER

divano\_sofa

design Mauro Lipparini

Divano tappezzato in pelle o tessuto, con base a piattaforma e schienale e braccioli trapezoidali imbottiti, scocca interna in legno massello e multistrati di pioppo e faggio. Cuscini di seduta in poliuretano, memory foam® e piuma. Cuscini di schienale con lavorazione “chevron” in poliuretano e piuma. Disponibile anche con bracciolo e schienale in versione “board” in legno rivestito in pelle, tessuto o pelle intrecciata con elementi strutturali e decorativi in ottone massiccio satinato con placche incise con logo Visionnaire, cuscini schienale in diverse misure in poliuretano e piuma. Gli elementi laterali “board” sono disponibili anche con piattaforma estesa “extension” sotto il bracciolo di + 24 cm.

*Upholstered leather or fabric sofa, with platform base and backrest and trapezoidal upholstered armrests, inner shell in solid wood and poplar and beech plywood. Seat cushions in polyurethane, memory foam® and feather. Back cushions with “chevron” processing in polyurethane and feather. Also available with armrest and backrest in the “board” version in wood upholstered in leather, fabric or woven leather with structural and decorative elements in solid satin brass with engraved plaques with Visionnaire logo, backrest cushions in different sizes in polyurethane and feather. The side “board” elements are also available with optional “extension” platform under the armrest of + 24 cm.*

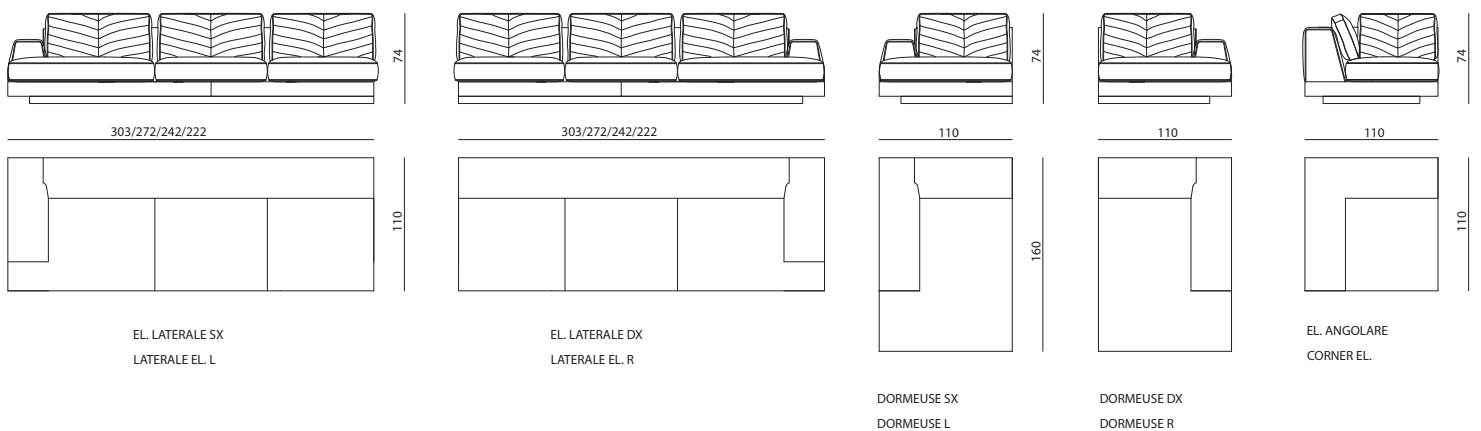



**RYLAN**  
tavolo basso\_ *low table*





## RYLAN

tavolo basso\_low table  
design Mauro Lipparini

Tavolo basso ovale con basamento obliquo in legno rivestito in acciaio inox satinato e top obliquo girevole in legno laccato lucido. Il top può ruotare di 180°.

*Oval coffee table with wooden oblique stand covered in satin stainless steel and swivel oblique top in glossy lacquered wood. The top can rotate 180°.*

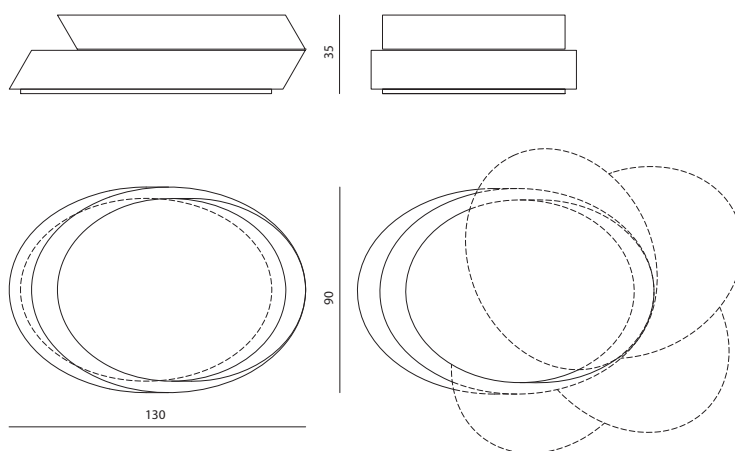





**DANNY**  
mobile basso\_ *low cabinet*





## DANNY

mobile basso\_low cabinet  
design Mauro Lipparini

Mobile basso con 4 ante, struttura esterna in legno laccato lucido esternamente e rivestito internamente in acciaio inox satinato. Top e ante rivestite in essenza laccata al poliestere lucido, profili top in acciaio.

*Low cabinet with 4 doors, external structure in polished lacquered wood and internally covered in satin stainless steel. Top and doors in veneered wood in glossy lacquered finishing, top profiles in stainless steel.*

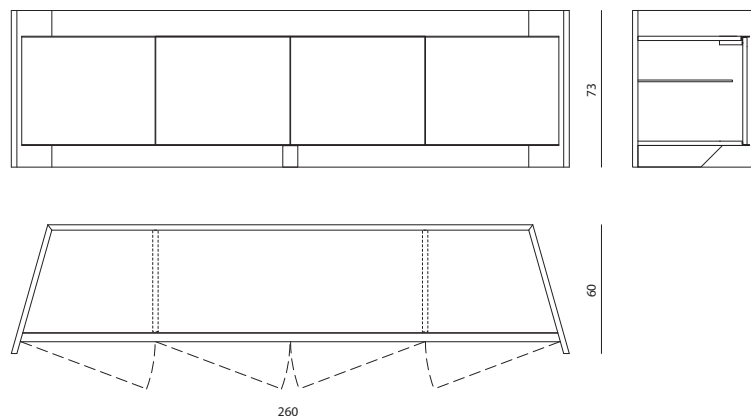

**DANNY**  
*consolle\_console*









## DANNY

consolle\_console  
design Mauro Lipparini

Consolle con tre cassetti, struttura esterna in legno laccato lucido esternamente e rivestito internamente in acciaio inox satinato. Top rivestito in essenza laccata al poliestere lucido, cassetti disponibili in essenza o rivestiti in pelle intrecciata. Profili top in acciaio inox.

*Console with 3 drawers, external structure in polished lacquered wood and internally covered in satin stainless steel. Top in veneered wood in glossy lacquered finishing, drawers in veneered wood or upholstered in woven leather. Top profiles in stainless steel.*

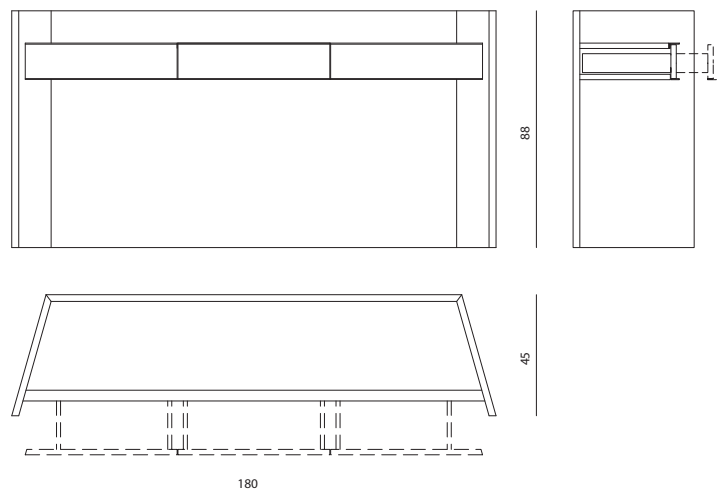







**KALGAN - BILBO - KAE**  
*plafoniere\_ceiling lamps*





## KALGAN - BILBO - KAEI

plafoniere\_ceiling lamps  
design Marco Piva

Lampade a sospensione in vetro con trattamento superficiale di vaporizzazione metallica di ottone antico, titanio sfumato e rame brunito. Sorgente luminosa a LED - COB 9W con diffusore interno in pirex satinato. Disponibili singolarmente e come plafoniere da tre e nove elementi.

*Suspension lamps in glass with surface treatment of metal vaporization of antique brass, titanium fade and dark copper. LED - COB 9W light source with internal diffuser in satin Pyrex. Available individually or as ceiling lights of three and nine elements.*

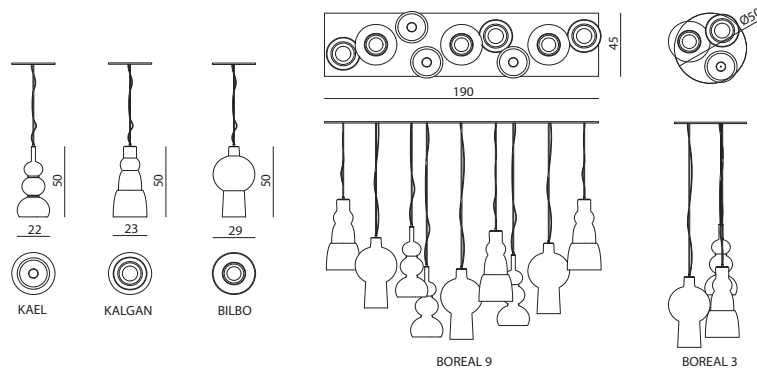





**K E R W A N**

---

*dining table*





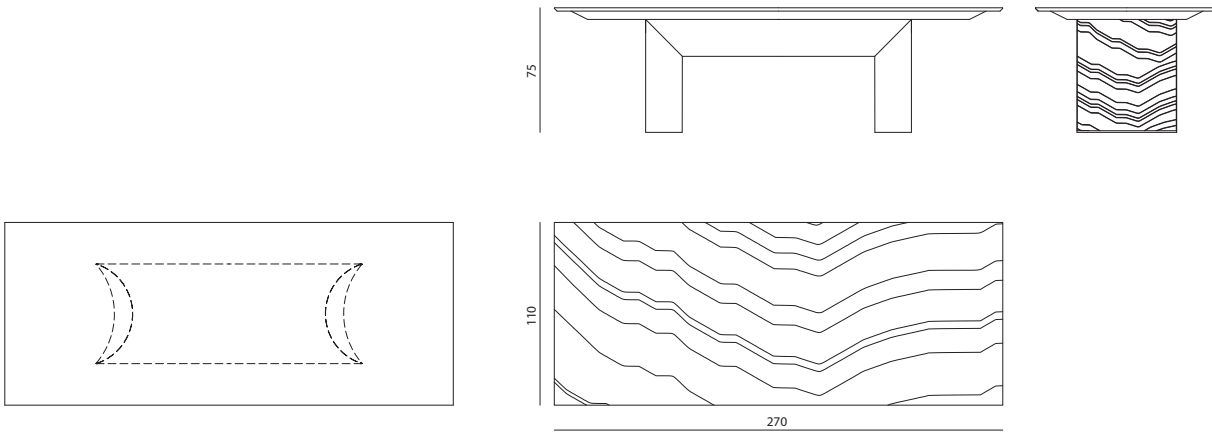





## **KERWAN**

tavolo da pranzo\_*dining table*  
design Alessandro La Spada

Tavolo da pranzo, top in lastra di marmo con bordo bisellato in negativo e sottotop in legno laccato. Basamento in acciaio inox lucido curvato su tre lati. Le superfici esterne concave del basamento sono realizzate in marmo curvato e lucidato.

*Dining table, top in marble with bevelled edge and under board in lacquered wood. Polished and curved stainless steel base with concave external surfaces made of curved and polished marble.*

**ASTRID**  
*sedia\_chair*





## ASTRID

sedia\_chair

design Alessandro La Spada

Sedia imbottita con scocca in legno curvato imbottita e rivestita in pelle o tessuto. Gambe in fusione di alluminio satinato e laccato oro.

*Padded chair with curved wood shell upholstered and covered in leather or fabric. Legs in cast aluminum and gold lacquered.*

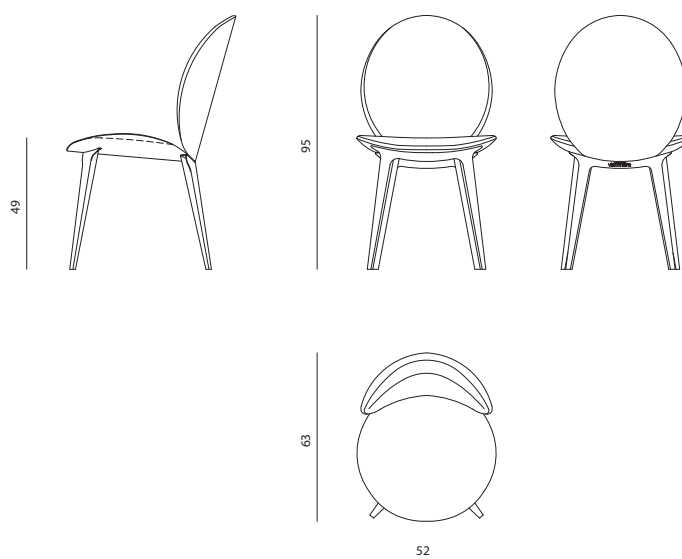



## EKOS

panca\_bench  
design Alessandro La Spada

Panca imbottita con seduta lineare rivestita in pelle o tessuto, basamento rivestito in acciaio inox lucido curvato, con elementi laterali in marmo massello a forma concava.

*Upholstered bench with linear seat in leather or fabric, base covered in curved polished stainless steel, with concave-shaped solid marble side elements.*

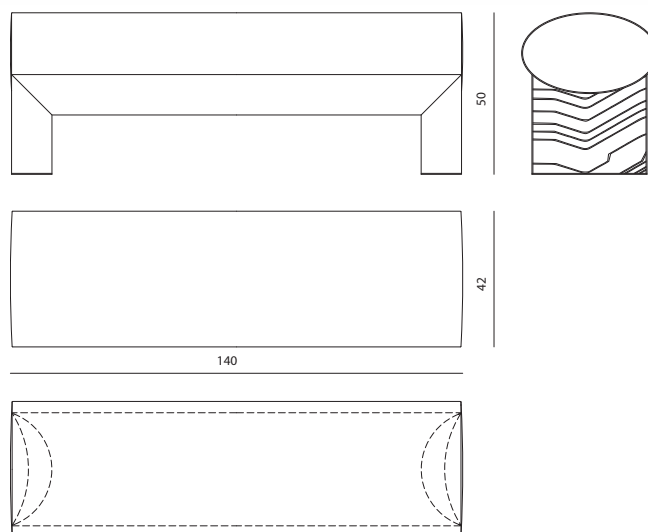



**EKOS**  
*panca\_bench*





## EKOS

consolle\_console  
design Alessandro La Spada

Consolle in legno con top e gambe concavi rivestiti in essenza con finitura lucida 100 gloss, la parte interna è rivestita in acciaio inox lucido curvato. Secondo top in cristallo.

Consolle in marmo massello con top e gambe a lavorazione concava lucidata a mano, la parte interna è rivestita in acciaio inox lucido curvato. Secondo top in cristallo fumè.

*Console in wood with polished veneered concave legs and top, the inside part is covered in curved polished stainless steel. Second crystal top.*

*Console in solid marble with concave work for top and legs, handmade polished. The inside part is covered in curved polished stainless steel. Second smoked crystal top.*

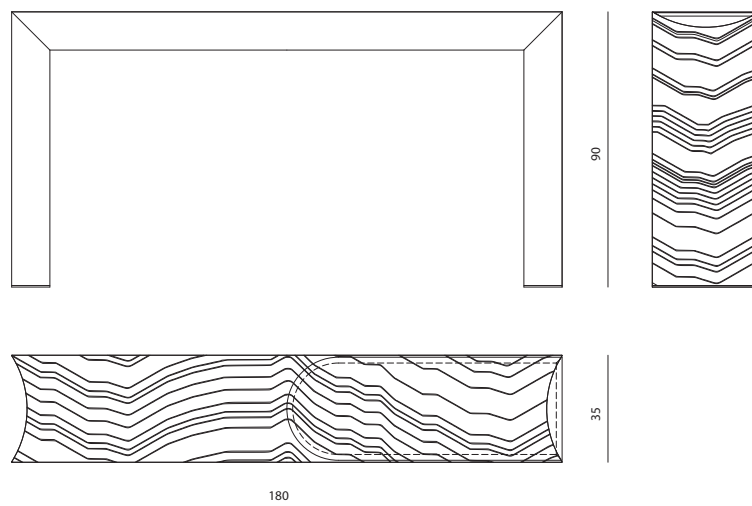

**EKOS**  
consolle\_console



**THAMOS**  
mobile con ante\_cabinet







## THAMOS

mobile con ante\_cabinet  
design Alessandro La Spada

Mobile contenitore con quattro ante, struttura in legno con fianchi concavi e top in essenza con finitura manuale lucida 100 gloss. Cornice interna di fianchi e top in acciaio inox lucido curvato verso l'interno. Gli interni del mobile sono laccati in tinta RAL con finitura opaca, con cassetti interni parzialmente a vista anche con ante chiuse. Illuminazione interna a led sotto-top.

*Cabinet with four doors, wooden frame with concave sides and top veneered with 100 gloss handmade finishing. Internal frame of sides and top in polished stainless steel bent inwards. Interiors laquered in RAL color with a matte finish, with visible internal drawers even with closed doors. Inside led light under the top.*



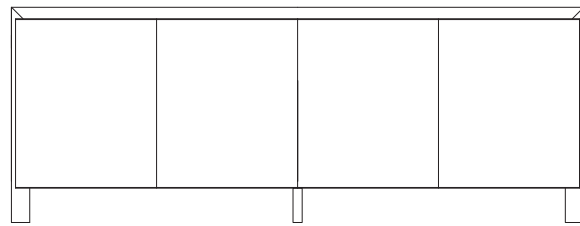
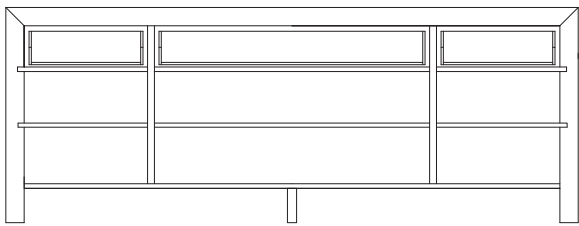

94

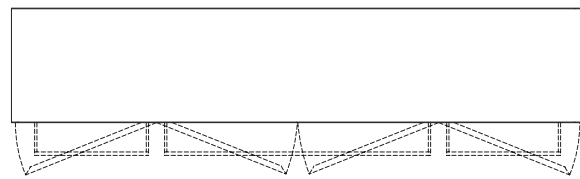
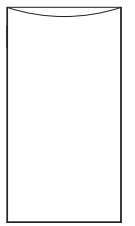

50

250



**AKIRA**  
*lampadario\_chandelier*





## AKIRA

lampadario\_chandelier  
design Alessandro La Spada

Lampadario a 16 luci con struttura in ottone lucidato, i bracci curvati sono fissati al fusto centrale tramite elementi in ottone massiccio. Portalampe in ottone tornito e luci G9 da 40 W con diffusore in vetro satinato. Paralumi concavi "a ventaglio" in tessuto stampato con diffusore interno in tessuto moiré.

*16 lights chandelier with polished brass structure, the curved arms are fixed to the central stem by solid brass elements. Lampholders in turned brass and G9 40 W bulbs with frosted glass diffuser. Concave "fan-shaped" lampshades in printed fabric with internal moiré fabric diffuser.*

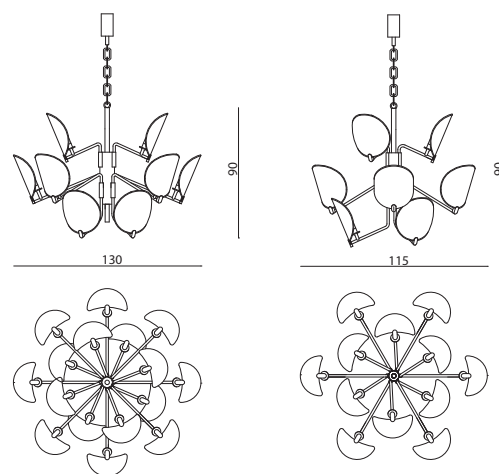





**AKIRA**  
applique\_wall lamp



**AKIRA**  
applique\_wall lamp  
design Alessandro La Spada

Applique a 4 luci con struttura in ottone lucidato, i bracci curvati sono fissati al fusto centrale tramite elementi in ottone massiccio. Portalampade in ottone tornito e luci G9 da 40 W con diffusore in vetro satinato. Paralumi concavi "a ventaglio" in tessuto stampato con diffusore interno in tessuto moiré.

*4 lights wall lamp with polished brass structure, the curved arms are fixed to the central stem by solid brass elements. Lampholders in turned brass and G9 40 W bulbs with frosted glass diffuser. Concave "fan-shaped" lampshades in printed fabric with internal moiré fabric diffuser.*

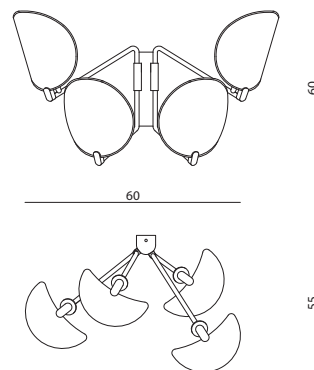





## AKIRA

lampada da tavolo\_ *table lamp*  
design Alessandro La Spada

Lampada da tavolo a una luce con base di appoggio in ottone lucidato, con paralume verticale concavo "a ventaglio" in tessuto stampato con diffusore interno in tessuto moiré. Paralume posteriore antiabbagliante in acciaio inox microforato con trama grafica "foliage". Portalampada in ottone tornito e luce G9 da 40 W con diffusore in vetro.

*One light table lamp with polished brass base, with concave fan shaped vertical lampshade in printed fabric with internal moiré fabric diffuser. Anti-glare rear lampshade in micro-perforated stainless steel with "foliage" graphic texture. Lampholder in turned brass and G9 40 W bulb with glass diffuser.*

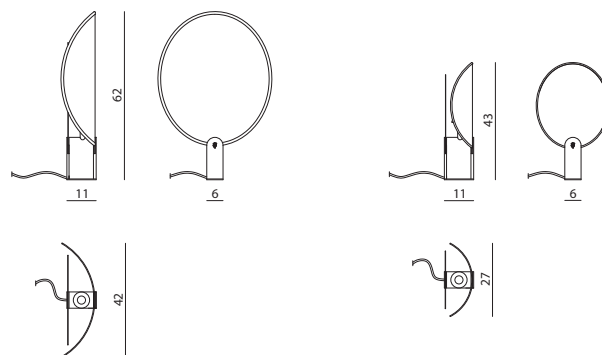



**AKIRA**  
lampada da tavolo *\_table lamp*







**K A T H R Y N**

---

*outdoor*



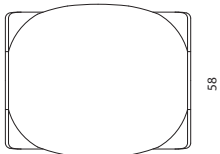
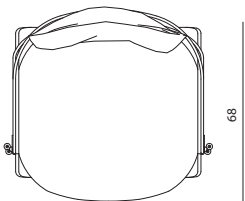
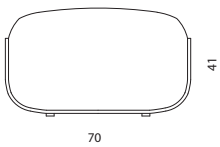
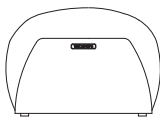
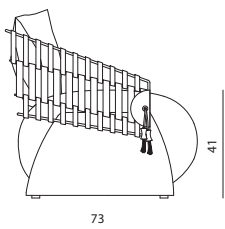
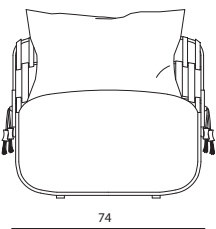





## **KATHRYN OUTDOOR**

poltroncina outdoor\_*outdoor armchair*  
design Giuseppe Viganò

Poltroncina outdoor, struttura in multistrati curvato rivestito teak contenente un cuscino di seduta imbottito in tessuto o pelle da esterno. Schienale curvo formato da struttura in ottone e acciaio inox, intrecciata in corda di lino o sintetico e bacchette di teak massello. Stemma decorativo sui braccioli con nappe in cuoio e ottone. Cuscino volante per lo schienale in pelle o tessuto da esterno.

*Outdoor armchair, structure in curved plywood covered with teak containing a seat cushion upholstered in fabric or leather for outdoor use. Curved backrest made of brass and stainless steel structure, woven with linen or synthetic rope and solid teak rods. Decorative coat of arms on the armrests with leather and brass tassels. Loose cushion for the back in leather or outdoor fabric.*

## **KATHRYN OUTDOOR**

pouf outdoor\_*outdoor pouffe*  
design Giuseppe Viganò

Pouf outdoor, struttura in multistrati curvato rivestito teak contenente un cuscino di seduta imbottito in tessuto o pelle da esterno.

*Outdoor pouffe, structure in curved plywood covered with teak containing a seat cushion upholstered in fabric or leather for outdoor use.*



## LUKE OUTDOOR

lampada da terra outdoor\_outdoor floor lamp



### LUKE OUTDOOR

lampada da terra outdoor\_outdoor floor lamp  
design Giuseppe Viganò

Lampada da terra outdoor, struttura in multistrati curvato rivestito teak contenente una sfera luminosa in polietilene con grado di isolamento IP55, portalampada E27.

*Outdoor floor lamp, structure in curved plywood covered in teak containing a luminous sphere in polyethylene with IP55 insulation degree, E27 lampholder.*

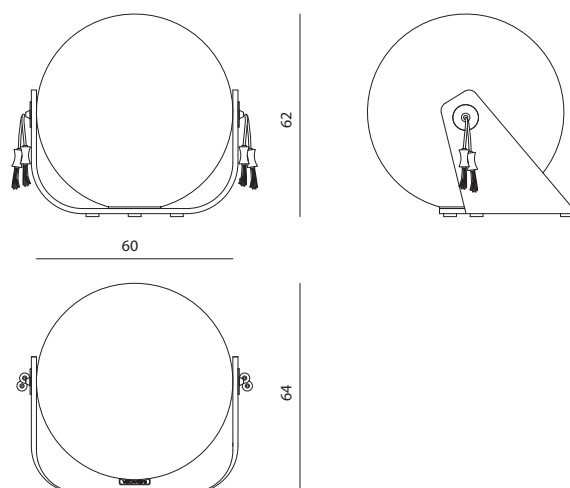





**R Ê V E R I E**

---

*bed*











## RÊVERIE

letto\_bed

design Roberto Lazzeroni

Letto imbottito in pelle o tessuto con testata alta divisa in due sezioni orizzontali a diversa inclinazione. La parte esterna può essere rivestita in contrasto con la parte interna, divisa da un filetto in pelle. Sommier imbottito con giroletto inclinato verso l'interno e basamento in legno laccato lucido con angolari decorativi in ottone satinato. Struttura interna in masselli e multistrati di legno, rete a doghe in legno massello. Supporti rete/materasso regolabili in altezza.

*Upholstered bed in leather or fabric with high head divided into two horizontal sections with different inclination. The external part can be covered in contrast with the inner part, divided by a leather thread. Padded sommier with inwardly inclined bed frame; polished lacquered wooden base with decorative satin brass corners. Internal structure in solid and multilayer wood, solid wood slatted base. Height adjustable slats/mattress supports.*

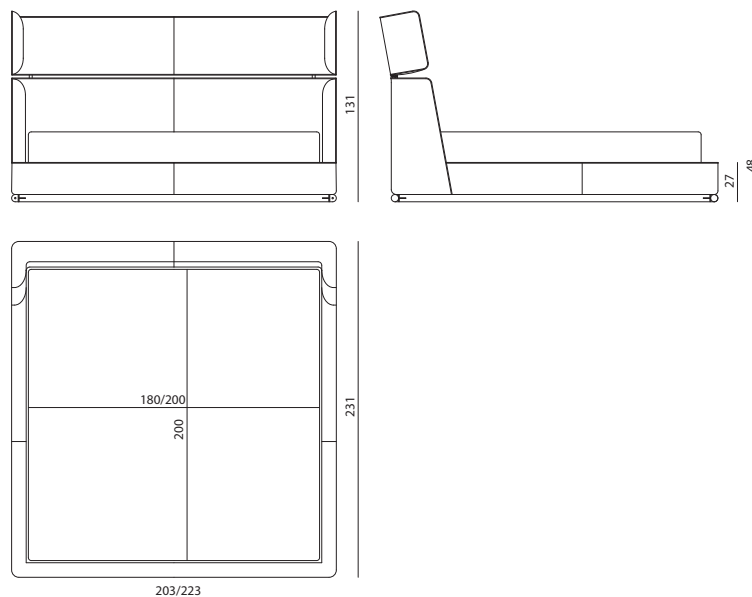

**NOMOS**  
comodino\_bedside table



**NOMOS**

comodino\_bedside table  
design Roberto Lazzeroni

Comodino con 2 cassetti con corpo centrale semi-ellittico disponibile in legno curvato su tutti i lati, superficie esterna con profili a rilievo, finitura laccato lucido o rivestito in pelle. Top in marmo inserito in una cornice sagomata in legno massello di rovere con finitura nera a poro aperto. Base conica in legno nero e profilo inferiore in metallo satinato. Interno cassetti in essenza rovere nero e interno in microfibra nera.

*Bedside table with 2 drawers with semi-elliptical central body in curved wood on all sides, external surface with raised profiles, glossy lacquered finish or covered in leather. Marble top inserted in a molded frame in solid Oak wood with black open-pore finish. Conical base in black wood and lower profile in satin metal. Drawers interiors in black oak and black microfibre inside.*

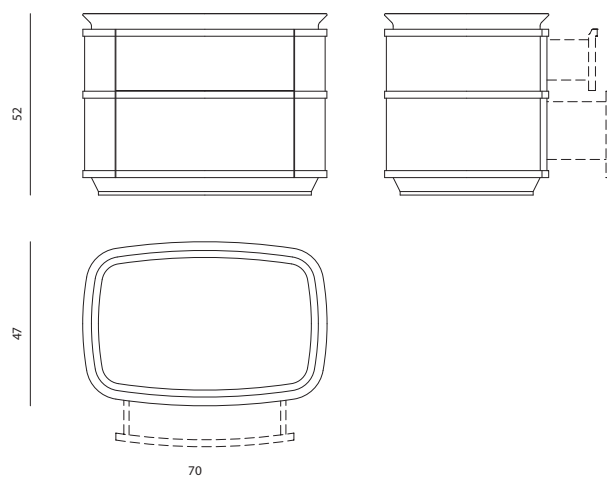







**NOMOS**  
cassettiera\_chest of drawers





## NOMOS

cassettiera\_chest of drawers  
design Roberto Lazzeroni

Cassettiera con 6 cassetti con corpo centrale semi-ellittico in legno curvato su tutti i lati, superficie esterna con profili a rilievo, finitura laccato lucido. Top in marmo inserito in una cornice sagomata in legno massello di Rovere con finitura nera a poro aperto. Base conica in legno nero e profilo inferiore in metallo satinato. Interno cassetti in essenza rovere nero e interno in microfibra nera. Disponibile nella versione "Wall" con schienale piatto.

*Chest of drawers with 6 drawers with semi-elliptical central body in curved wood on all sides, external surface with raised profiles, glossy lacquered finish. Marble top inserted in a molded frame in solid Oak wood with black open-pore finish. Conical base in black wood and lower profile in satin metal. Drawers interiors in black oak and black microfibre inside. Also available in the "Wall" version with flat back.*

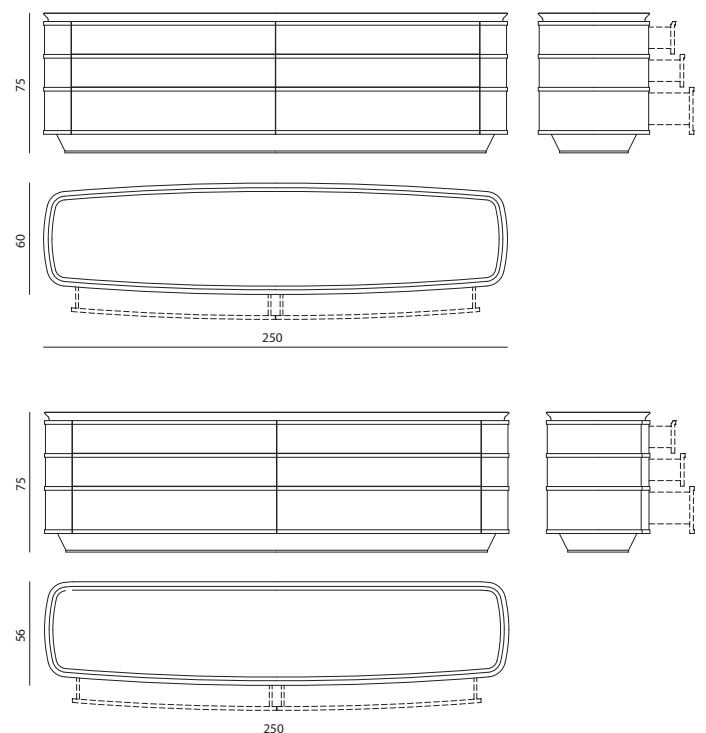







**RUPERT**  
tavolo basso\_ *low table*





## RUPERT

tavolo basso\_low table  
design Roberto Lazzeroni

Tavolino basso ovale con top in fibra di legno lavorata dal pieno in forma organica con finitura laccata 100 gloss. Vano porta oggetti ricavato nel piano superiore. La parte inferiore del top, di sagoma eccentrica, confluisce in una base conica in marmo massiccio, scavato da unico blocco. Basetta di appoggio in acciaio satinato.

*Oval low table with top in wood fiber graven organic form with 100 gloss lacquered finish. Object compartment in the top. The lower part, of eccentric shape, flows into a conical base in solid marble, milled from a single block. Support base in brushed steel.*

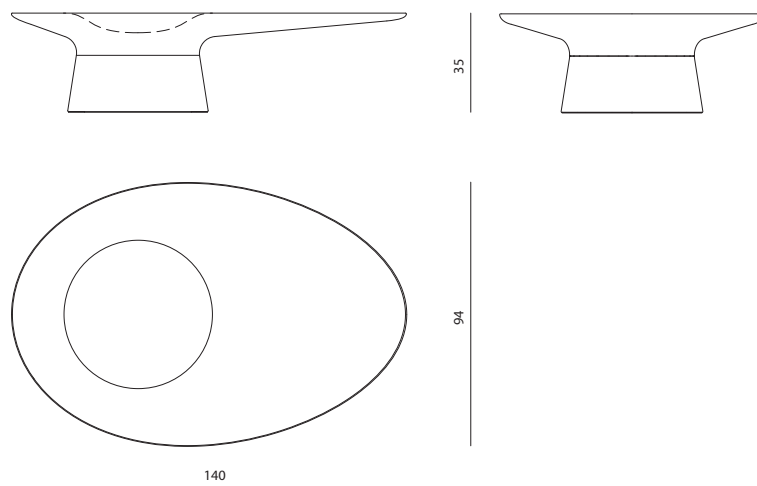





## TANYA

poltroncina\_ *armchair*  
design Roberto Lazzeroni

Poltroncina monoscocca in poliuretano stampato a freddo (densità 70 kg/mq) con scocca interna in metallo. Rivestimento in pelle o tessuto; la parte esterna può essere rivestita in contrasto con la parte interna, divisa da un filetto in pelle. Gambe costituite da una singola struttura in fusione di alluminio, con finitura antracite perlato e piedini in acciaio inox.

*Armchair in cold-cured PU Foam molding (density 70 kg/m<sup>2</sup>) with internal metal shell. Upholstery in leather or fabric; the external part can be covered in contrast with the internal part, divided by a leather thread. Legs made of a single structure in aluminum cast, with pearl anthracite finish and stainless steel feet.*

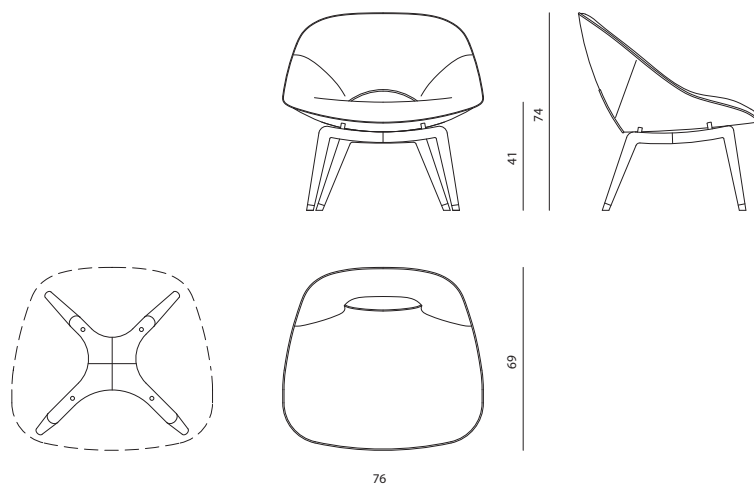



**TANYA**  
*poltroncina\_armchair*



**MILO**  
specchiera\_mirror

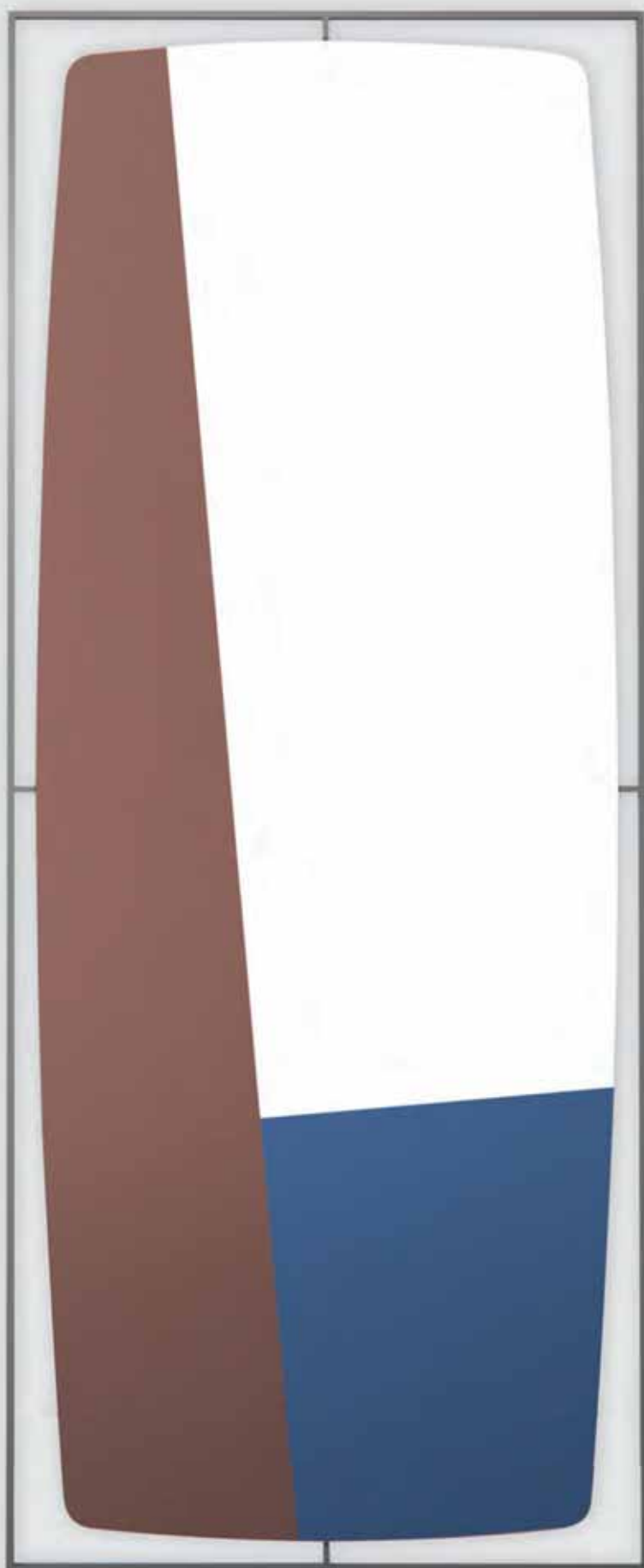

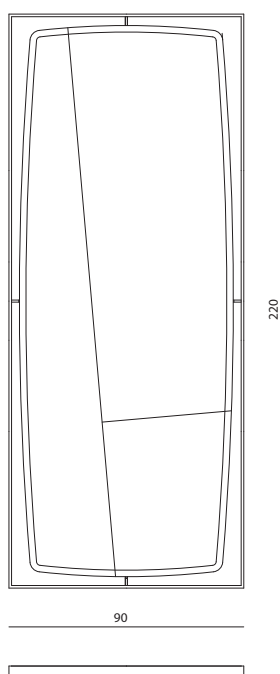

## MILO

specchiera\_mirror

design Roberto Lazzeroni

Specchiera in tre sezioni cromatiche con parti in specchio naturale, rosa e azzurro. Cornice in metallo separata dallo specchio da quattro elementi in ottone. Fondo in legno nero.

*Mirror in three chromatic sections with parts in natural, pink and blue mirror. Metal frame separated from the mirror by four brass elements. Black wooden back.*





**A N T H A R**

---

*sofa*



## ANTHAR

divano\_sofa

design Roberto Lazzeroni

Divano tappezzato in pelle o tessuto. Struttura in multistrati e massello di legno con schienale curvo sospeso, sedile molleggiato con cinghie elastiche e imbottitura in poliuretano a diverse densità, memory foam® e piuma d'oca. Cuscini volanti in piuma. Base sagomata in legno massello verniciato nero lucido. Disponibile anche pouf.

*Upholstered sofa in leather or fabric. Structure in plywood and solid wood with curved backrest, seat suspension with elastic straps and polyurethane padding in different densities, memory foam® and goose down. Loose cushions in feathers. Shaped base in solid black lacquered solid wood. Also available pouffe.*

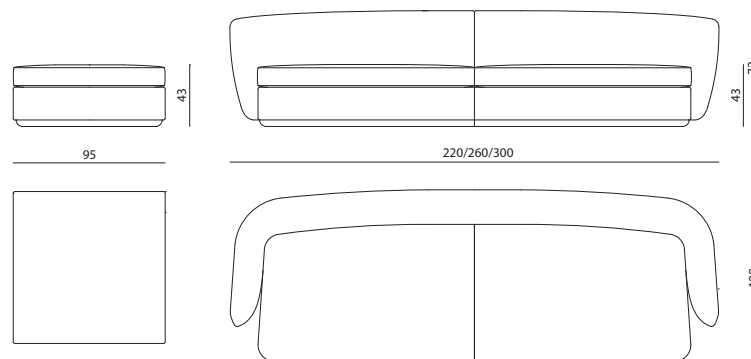









**ANTHAR**  
dormeuse

## **ANTHAR**

dormeuse  
design Roberto Lazzeroni

Dormeuse tappezzata in pelle o tessuto. Struttura in multistrati e massello di legno con schienale curvo sospeso, sedile molleggiato con cinghie elastiche e imbottitura in poliuretano a diverse densità, memory foam® e piuma d'oca. Cuscini volanti in piuma. Base sagomata in legno massello verniciato nero lucido.

*Dormeuse upholstered in leather or fabric. Structure in plywood and solid wood with curved backrest, seat suspension with elastic straps and polyurethane padding in different densities, memory foam® and goose down. Loose cushions in feathers. Shaped base in solid black lacquered solid wood.*



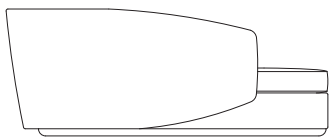

43

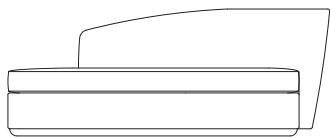

72

180

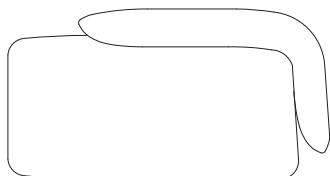

95

DORMEUSE SX  
DORMEUSE L

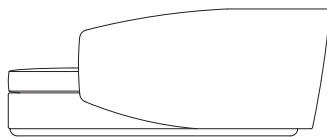

72

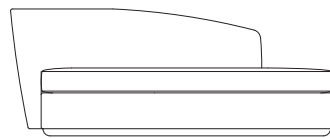

43

180

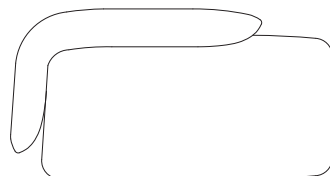

95

DORMEUSE DX  
DORMEUSE R



## KOBOL

mobile portalavabo singolo e doppio\_console with single and double basin





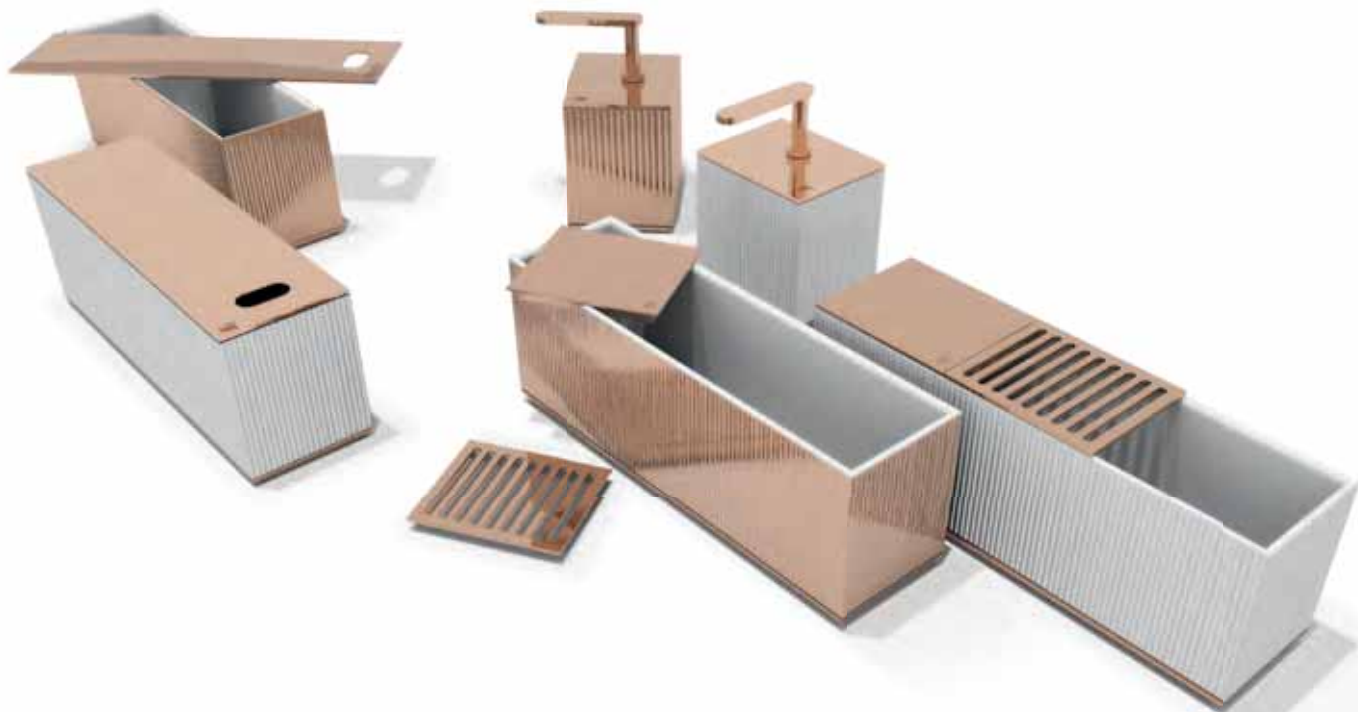

## KOBOL

accessori bagno\_*bathroom accessories*  
design Alessandro La Spada

Linea di accessori in ceramica rigata con dettagli in acciaio inox e ottone satinato, composta da bicchiere quadrato, dispenser sapone, contenitore rettangolare con coperchio e con griglia.

*Line of accessories in striped ceramic with details in stainless steel and satin brass, composed of square box, soap dispenser, rectangular container with lid and with grill.*

SCATOLA MULTIUSO - MULTIPURPOSE BOX

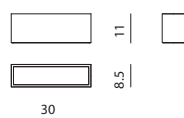

SCATOLA SINGOLA - SINGLE BOX

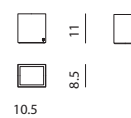

COVER "BIG"

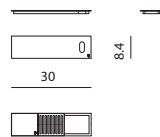

COVER "SMALL"

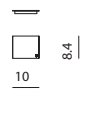

SOAP COVER

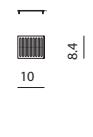

SOAP DISPENSER

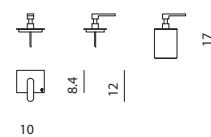

## KOBOL

mobile portalavabo\_*console with basin*  
design Alessandro La Spada

Console da toilette con due lavabi, mobile in legno con due cassetti provvisto di alzata laterale e posteriore in legno massello scolpito in bassorilievo con lavorazione "cannetè", internamente rivestita in acciaio inox satinato. Top in marmo sciolto con parte posteriore rialzata a supporto della rubinetteria. I rubinetti ed erogatore dell'acqua sono realizzati in ottone massiccio cromato. Lavabo in ceramica smaltata con esterno bianco oppure smaltato oro o platino, provvisto di piatto copri scarico in ceramica. Struttura portante in acciaio inox satinato, provvista di ripiano porta salviette in vetro o marmo. Predisposto per fissaggio a parete. Compatibile con linea accessori bagno Kobol.

*Console with two washbasins, wooden cabinet with two drawers with side and back in solid wood carved in bas-relief with "cannetè" processing, internally covered in satin stainless steel. Boxed marble top with raised rear part to support the taps. The faucets and the knobs are made of solid chromed brass. Glazed ceramic washbasin with white, gold or platinum enamelled exterior, provided with ceramic drain plate. Structure in brushed stainless steel, equipped with glass or marble towel shelf. Prepared for wall mounting. Compatible with Kobol bathroom accessories line.*

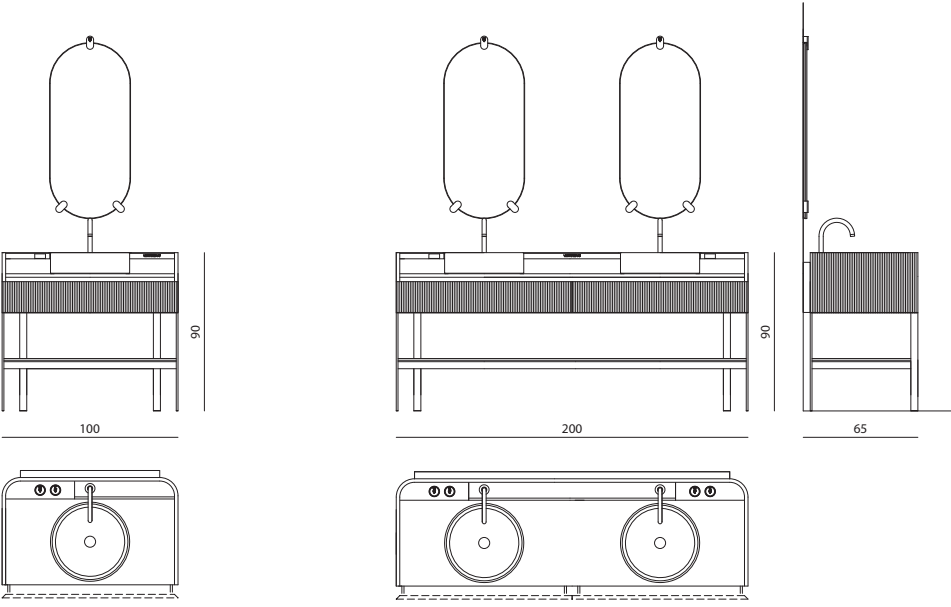



## KOBOL

specchio\_mirror  
design Alessandro La Spada

Specchio a posizionamento verticale con bordo molato e schienale in legno nero. Tre elementi decorativi in ottone satinato lungo il perimetro.

*Vertical mirror with ground edge and black wood back. Three decorative elements in satin brass along the perimeter.*

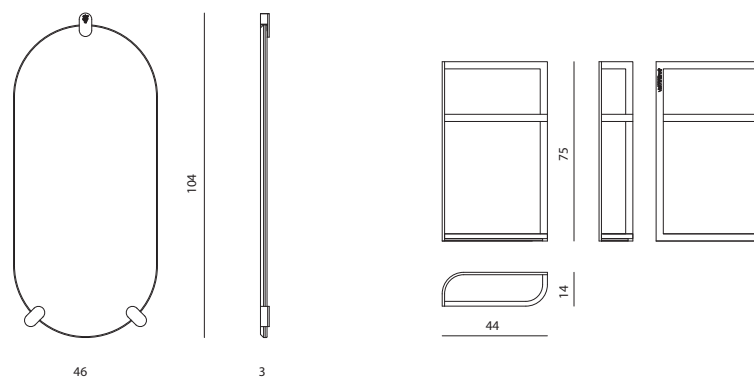

## KOBOL

portasciugamani\_towel holder  
design Alessandro La Spada

Portasciugamani in acciaio inox satinato con portaoggetti in marmo.

*Satin stainless steel towel rail with marble storage rack.*

**AKIRA**  
applique\_wall lamp



**AKIRA**

applique\_wall lamp  
design Alessandro La Spada

Applique a una luce con struttura in ottone lucidato. portalampada in ottone tornito e luce G9 da 40 W con diffusore in vetro satinato. Paralume concavo "a ventaglio" in tessuto stampato con diffusore interno in tessuto moiré.

Single light wall lamp with polished brass structure. Lampholder in turned brass and G9 40 W bulb with frosted glass diffuser. Concave "fan-shaped" lampshades in printed fabric with internal moiré fabric diffuser.

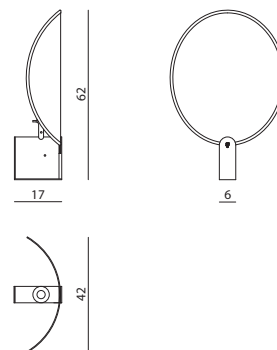



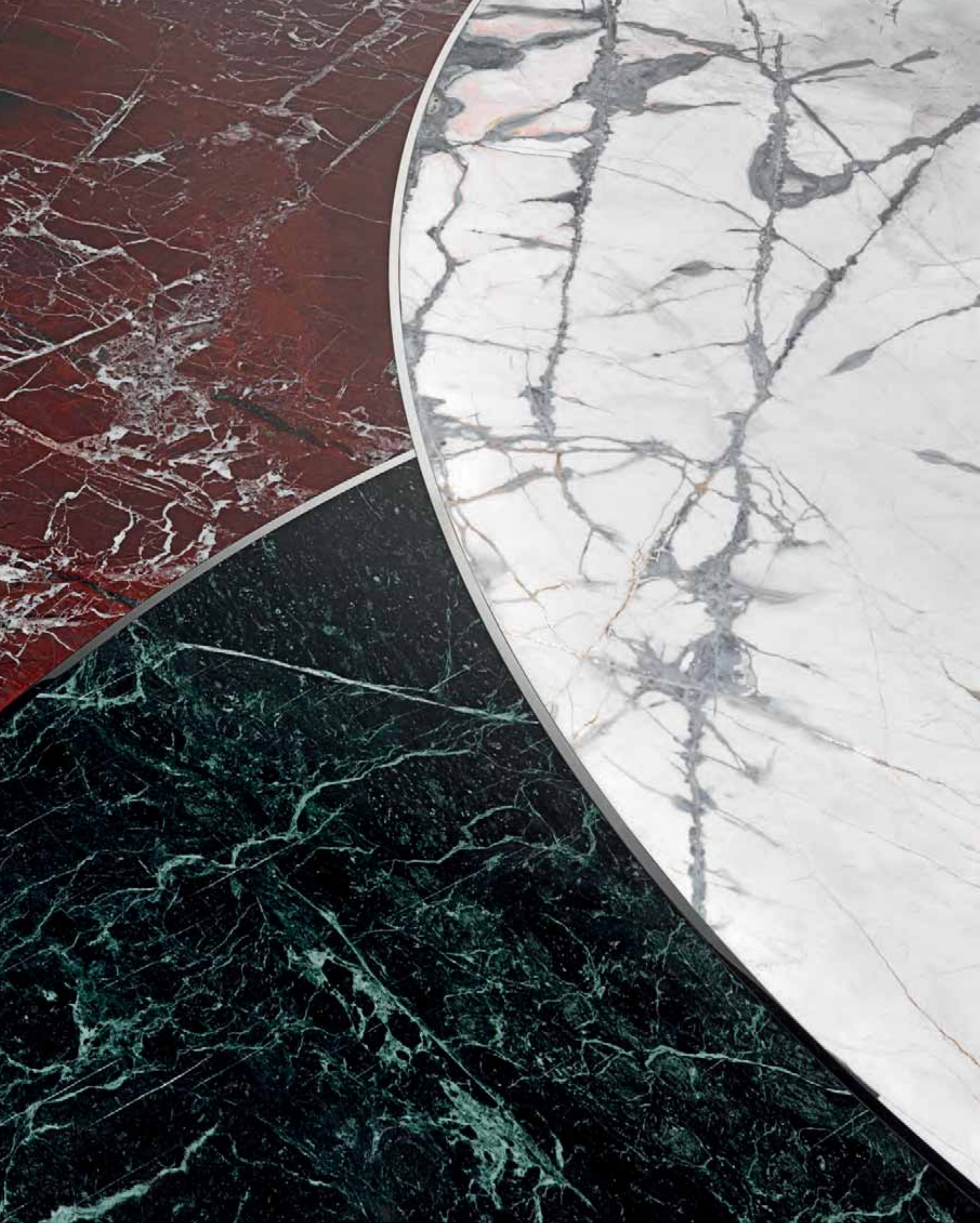



**J A S O N**

---

*dining table*











# JASON

tavolo da pranzo\_dining table



## JASON

tavolo da pranzo\_dining table  
design Roberto Lazzeroni

Tavolo da pranzo ovale con top in marmo composto da macro-mosaico in tre tipologie di marmo intarsiate con profilo metallico da 5 mm in acciaio inox lavorato a filo del piano. Il bordo del top è lavorato con profilo smussato. Sottotop in legno laccato lucido a sezione smussata. Basamento composto da due gambe concave in legno rivestito in cuoio nero con profili decorativi in acciaio inox satinato.

*Oval dining table with marble top composed of macro-mosaic in three types of marble inlaid with a 5 mm metal profile in stainless steel. The edge of the top is worked with a rounded edge. Undermount in glossy lacquered wood with rounded section. Base made of two concave wooden legs covered in black leather with decorative profiles in stainless steel.*

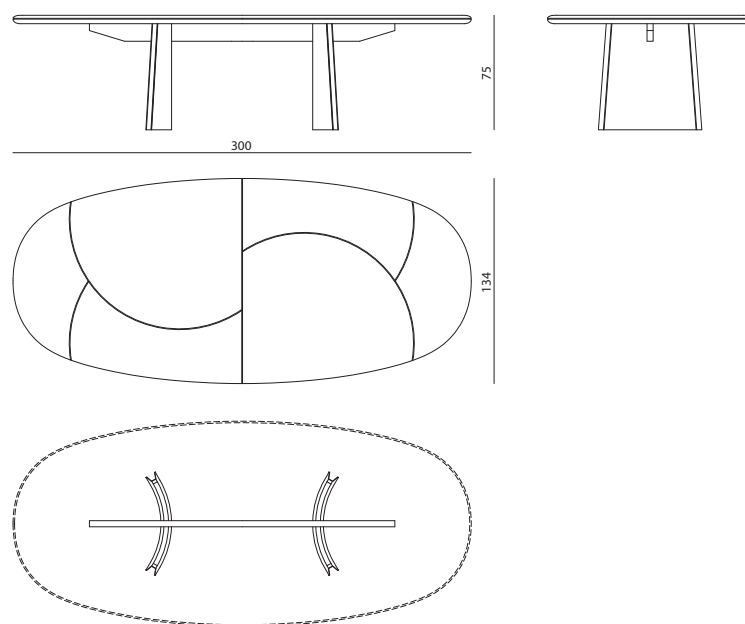

**JASON**  
tavolo da pranzo\_dining table





## JASON

tavolo da pranzo\_dining table  
design Roberto Lazzeroni

Tavolo da pranzo tondo con top in marmo composto da macro-mosaico in tre tipologie di marmo intarsiate con profilo metallico da 5 mm in acciaio inox lavorato a filo del piano. Il bordo del top è lavorato con profilo smussato. Sottotop in legno laccato lucido a sezione smussata. Basamento composto da due gambe concave in legno rivestito in cuoio nero con profili decorativi in acciaio inox satinato.

Round dining table with marble top composed of macro-mosaic in three types of marble inlaid with a 5 mm metal profile in stainless steel. The edge of the top is worked with a rounded edge. Undermount in glossy lacquered wood with rounded section. Base made of two concave wooden legs covered in black leather with decorative profiles in stainless steel.

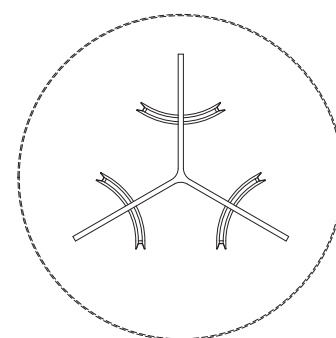
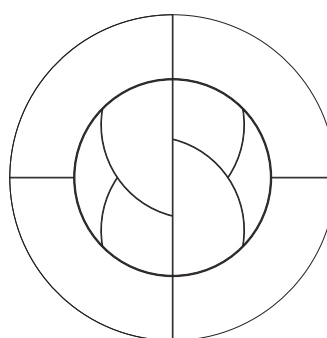
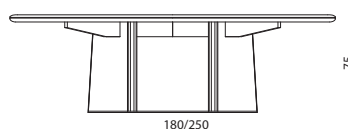

**TANYA**  
*sedia\_chair*







## TANYA

sedia\_chair

design Roberto Lazzeroni

Poltroncina monoscocca in poliuretano stampato a freddo (densità 70 kg/mq) con scocca interna in metallo. Rivestimento in pelle o tessuto; la parte esterna può essere rivestita in contrasto con la parte interna, divisa da un filetto in pelle. Gambe costituite da una singola struttura in fusione di alluminio, con finitura antracite perlato e piedini in acciaio inox.

*Armchair in cold-cured PU Foam molding (density 70 kg/m<sup>2</sup>) with internal metal shell. Upholstery in leather or fabric; the external part can be covered in contrast with the internal part, divided by a leather thread. Legs made of a single structure in aluminum cast, with pearl anthracite finish and stainless steel feet.*

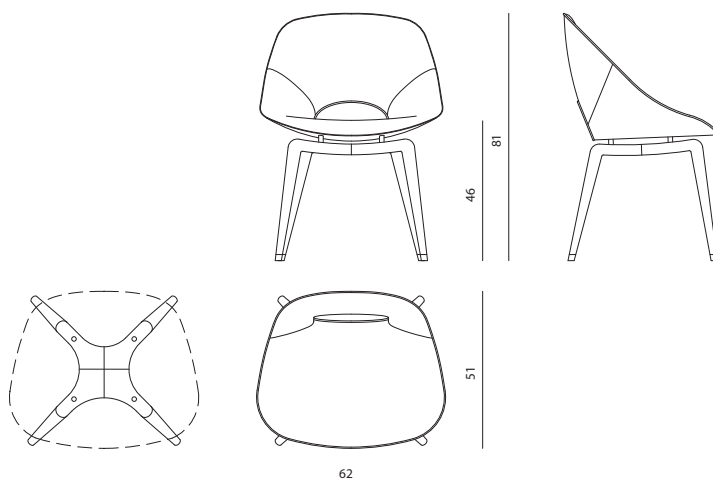



**NOMOS**  
mobile alto\_cabinet













## **NOMOS**

mobile alto\_cabinet  
design Roberto Lazzeroni

Mobile alto con 4 ante, corpo centrale semi-ellittico in legno curvato su tutti i lati, superficie esterna con profili a rilievo, finitura laccato lucido. Top in marmo inserito in una cornice sagomata in legno massello di rovere con finitura nera a poro aperto. Base conica in legno nero e profilo inferiore in metallo satinato. Interno mobile provvisto di ripiani e cassetti, finito in radica di eucalipto con finitura a poro aperto e schienali a specchio fumè. Cassetti rivestiti in cuoio con interno in microfibra. Disponibile nella versione "Wall" con schienale piatto.

*Cabinet with 4 doors, semi-elliptical central body in curved wood on all sides, external surface with raised profiles, glossy lacquered finish. Marble top inserted in a molded frame in solid Oak wood with black open-pore finish. Conical base in black wood and lower profile in satin metal. Interiors with shelves and drawers, finished in eucalyptus root with open pore finish and smoked mirror backs. Drawers covered in leather with microfibre lining. Also available in the "Wall" version with flat back.*

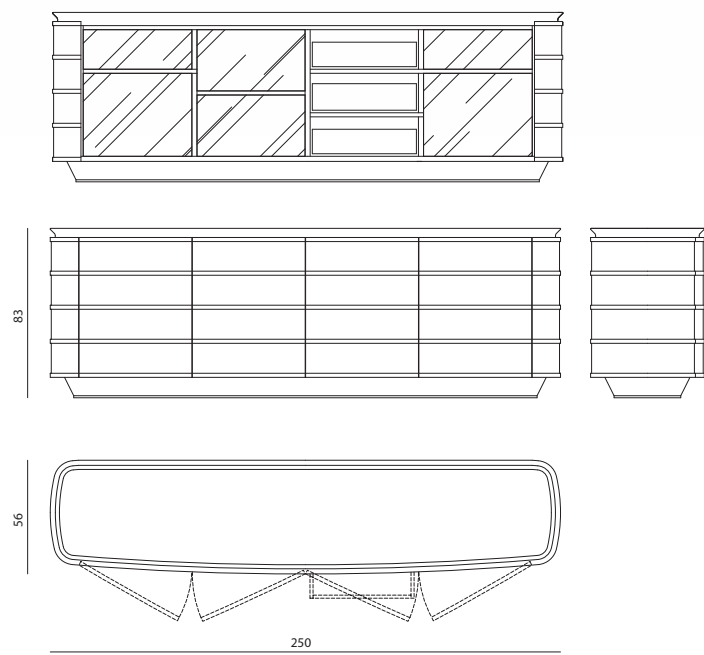
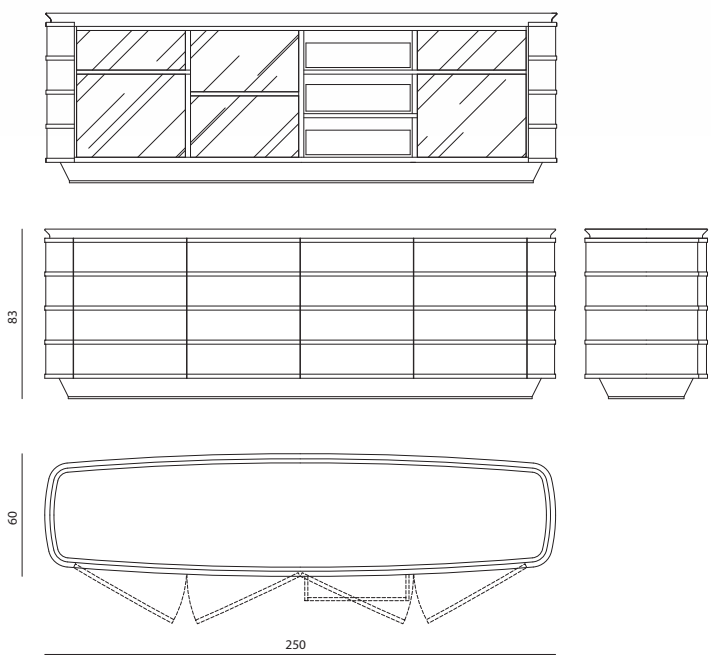

**NOMOS**  
mobile bar\_bar cabinet









## NOMOS

mobile bar\_bar cabinet  
design Roberto Lazzeroni

Mobile bar con 4 ante, corpo centrale semi-ellittico in legno curvato su tutti i lati, superficie esterna con profili a rilievo, finitura laccato lucido. Top in marmo inserito in una cornice sagomata in legno massello di rovere con finitura nera a poro aperto. Base conica in legno nero e profilo inferiore in metallo satinato. Le due ante laterali si aprono sui fianchi del mobile. Interno mobile provvisto di ripiani e cassetti, finito in radica di eucalipto con finitura a poro aperto e schienali a specchio fumè. Cassetto centrale rivestito in cuoio con interno in microfibra.

*Bar cabinet with 4 doors, semi-elliptical central body in curved wood on all sides, external surface with raised profiles, glossy lacquered finish. Marble top inserted in a molded frame in solid Oak wood with black open-pore finish. Conical base in black wood and lower profile in satin metal. The two side doors open on the sides of the cabinet. Interiors with shelves and drawers, finished in eucalyptus root with open pore finish and smoked mirror backs. Drawers covered in leather with microfibre lining.*

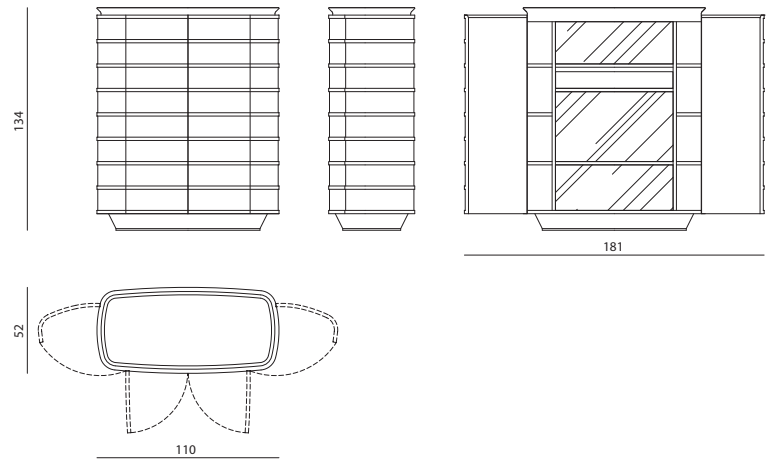



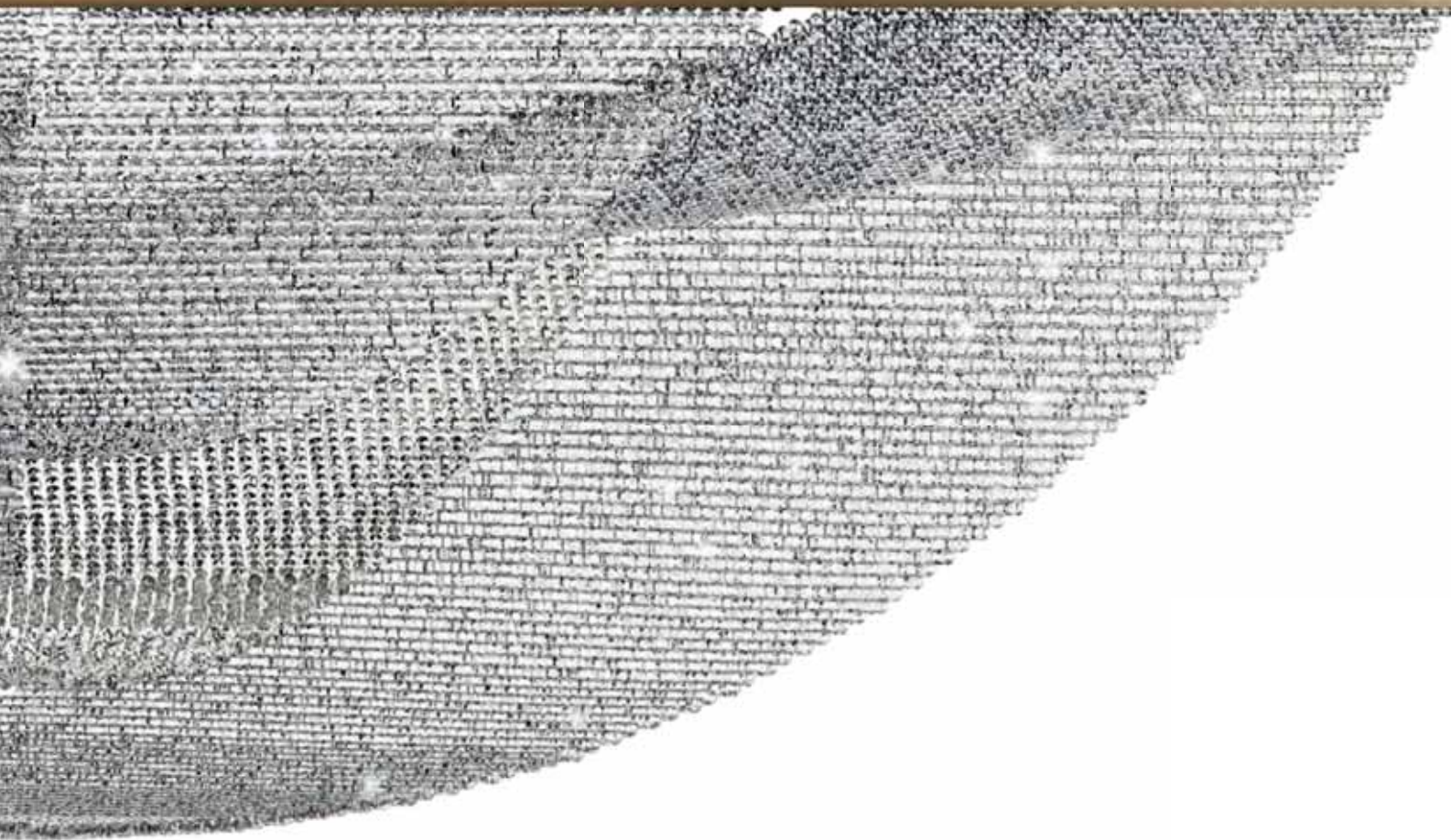

## SYLAR

plafoniera\_ceiling lamp  
design La Conca

Lampadario/plafoniera ovale in maglia di cristallo formato da cinque drappi cascanti, incrociati a diverse altezze. Struttura portante in acciaio inox satinato, impianto a 20 luci G9.

*Oval chandelier/ceiling lamp made of five crystal mesh hanging drapes, crossed at different heights. Support structure in brushed stainless steel, 20 G9 light system.*

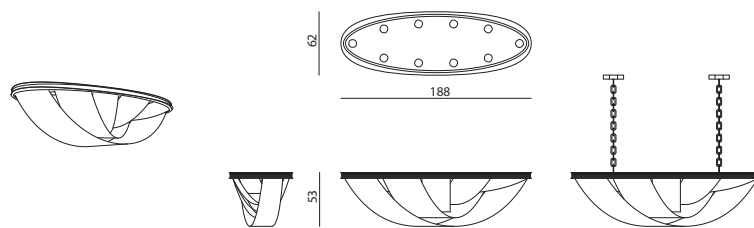



**SYLAR**  
plafoniera\_ceiling lamp





**T A Y L O R**

---

*modular sofa*







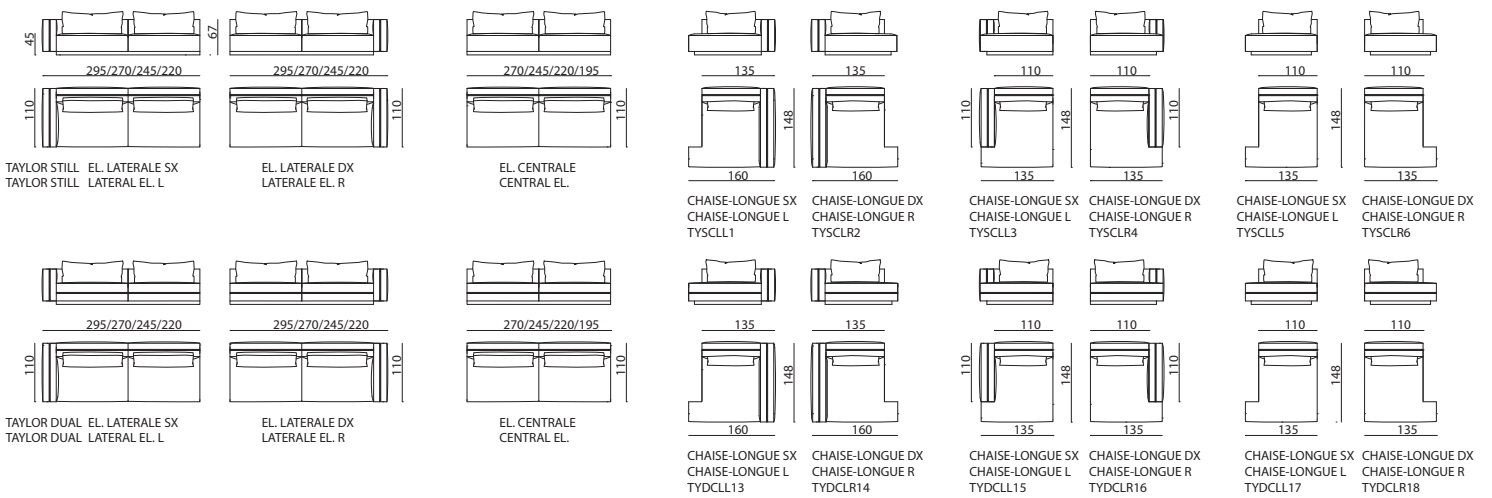
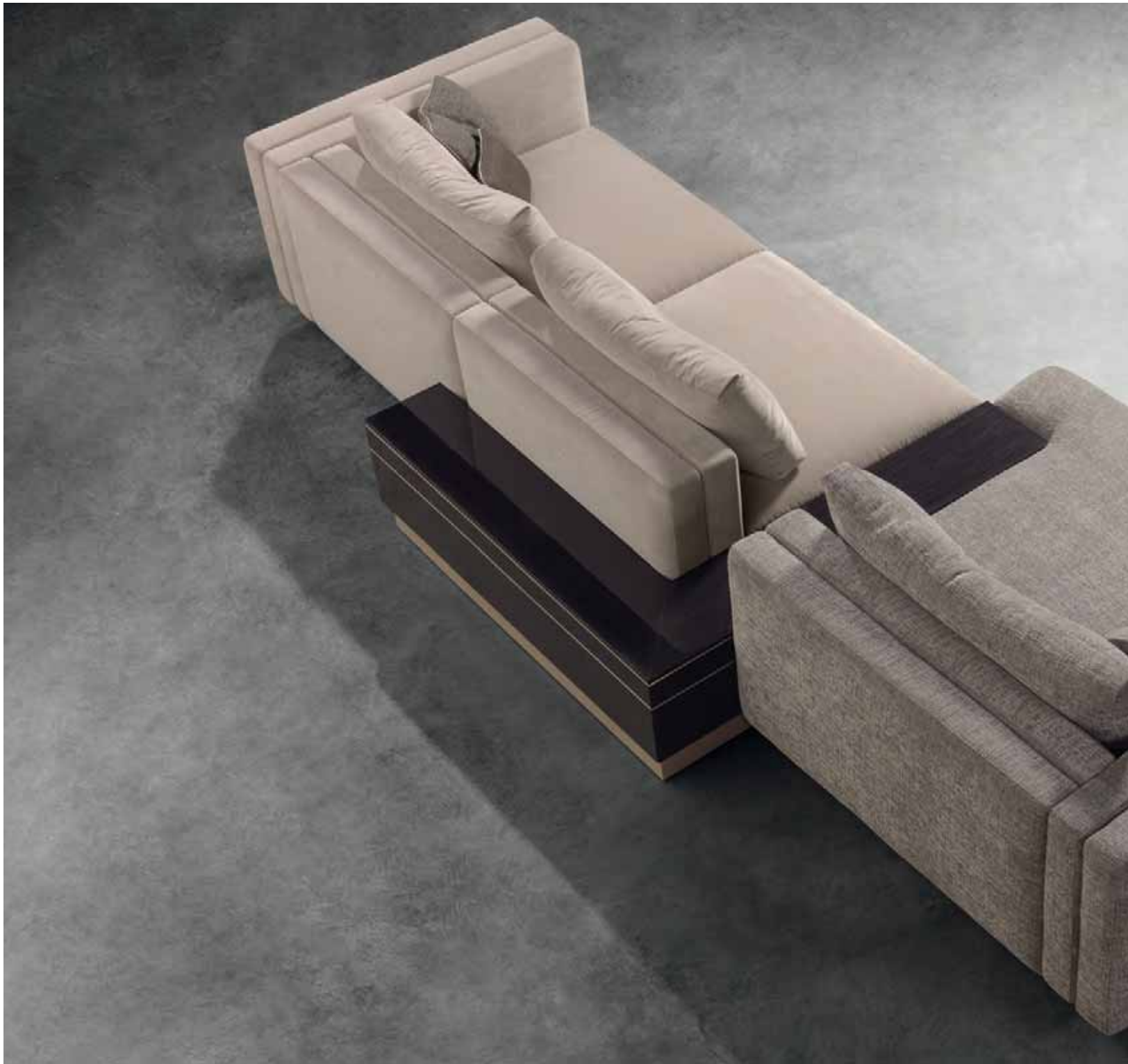



## TAYLOR

divano componibile\_modular sofa  
design Giuseppe Viganò

Divano componibile tappezzato in pelle o tessuto, con schienale e braccioli a doppio elemento con cuciture ribattute. Scocca interna in legno massello e multistrati, dotata di molleggio a cinghie elastiche. Cuscini di seduta in poliuretano, memory foam® e piuma. Cuscini di schienale e cuscini volanti in poliuretano e piuma. La scocca della seduta è disponibile nella versione Still a singolo elemento e nella versione Dual con base rigida e cuscini in appoggio. Base in legno H. 7 cm, rivestita in acciaio inox satinato. Gli elementi componibili offrono diverse possibilità di configurazione integrando gli elementi imbottiti Taylor con gli elementi in legno Agorà nella funzione di tavolini laterali o centrali.

*Upholstered modular sofa in leather or fabric with twin-element back and arms with riveted seams. Internal shell in solid wood and plywood, equipped with elastic belts springing. Seat cushions in polyurethane, memoryfoam® and feather. Back cushions and loose cushions in polyurethane and feather. The seat shell is available in the single element Still version and in the Dual version with base and cushions. Wooden base H. 7 cm, covered in satin stainless steel.*

*The modular elements offer different configuration possibilities by integrating the Taylor upholstered modular elements with Agorà wooden elements in the function of side or central tables.*

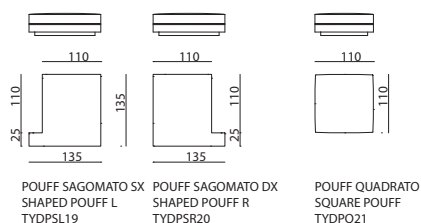
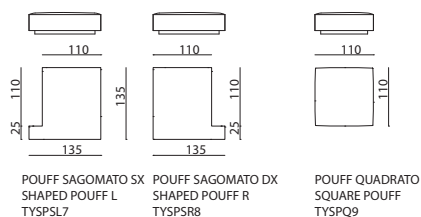





**T A Y L O R**

---

*sofa*





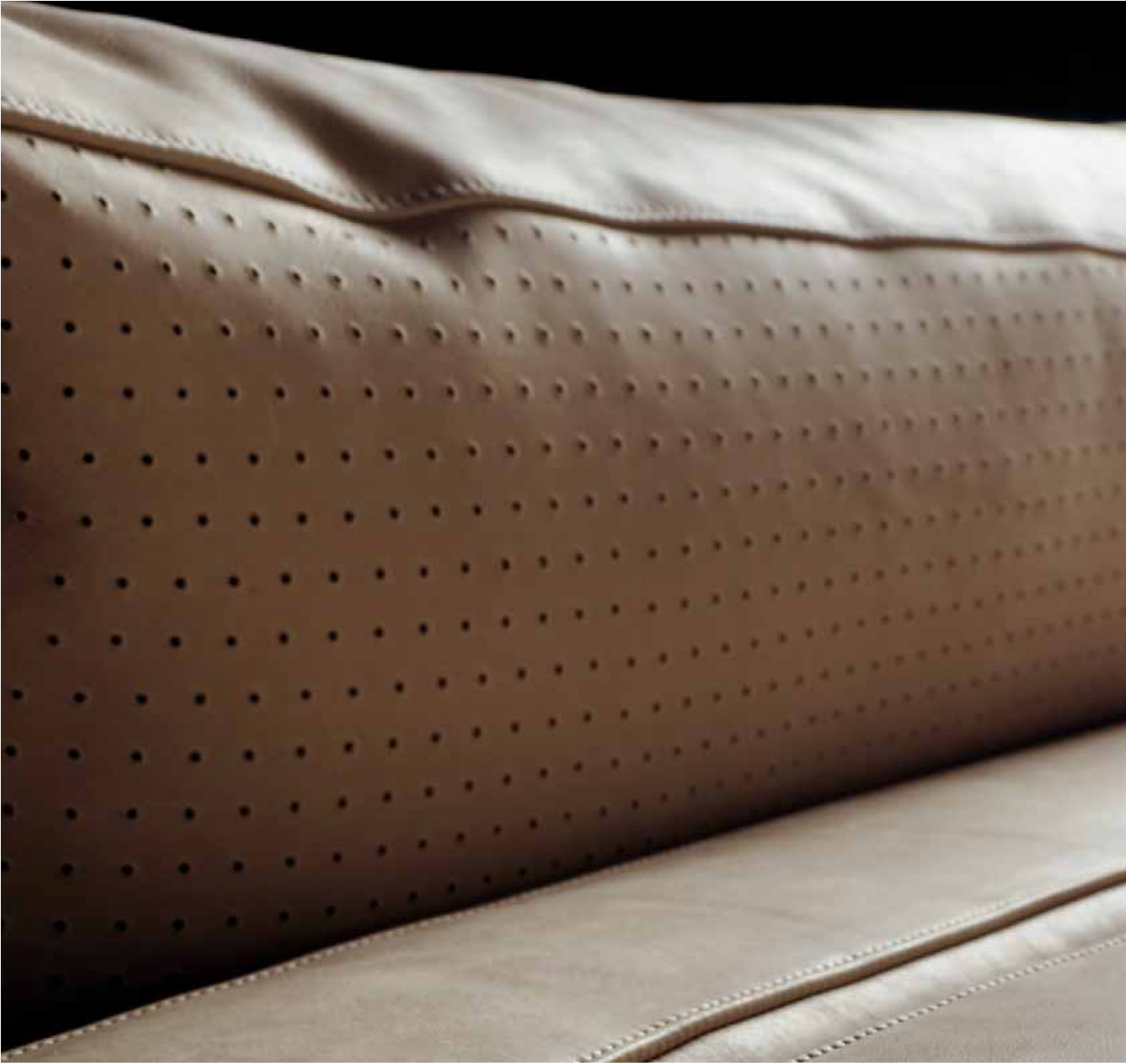



**TAYLOR**  
divano\_sofa

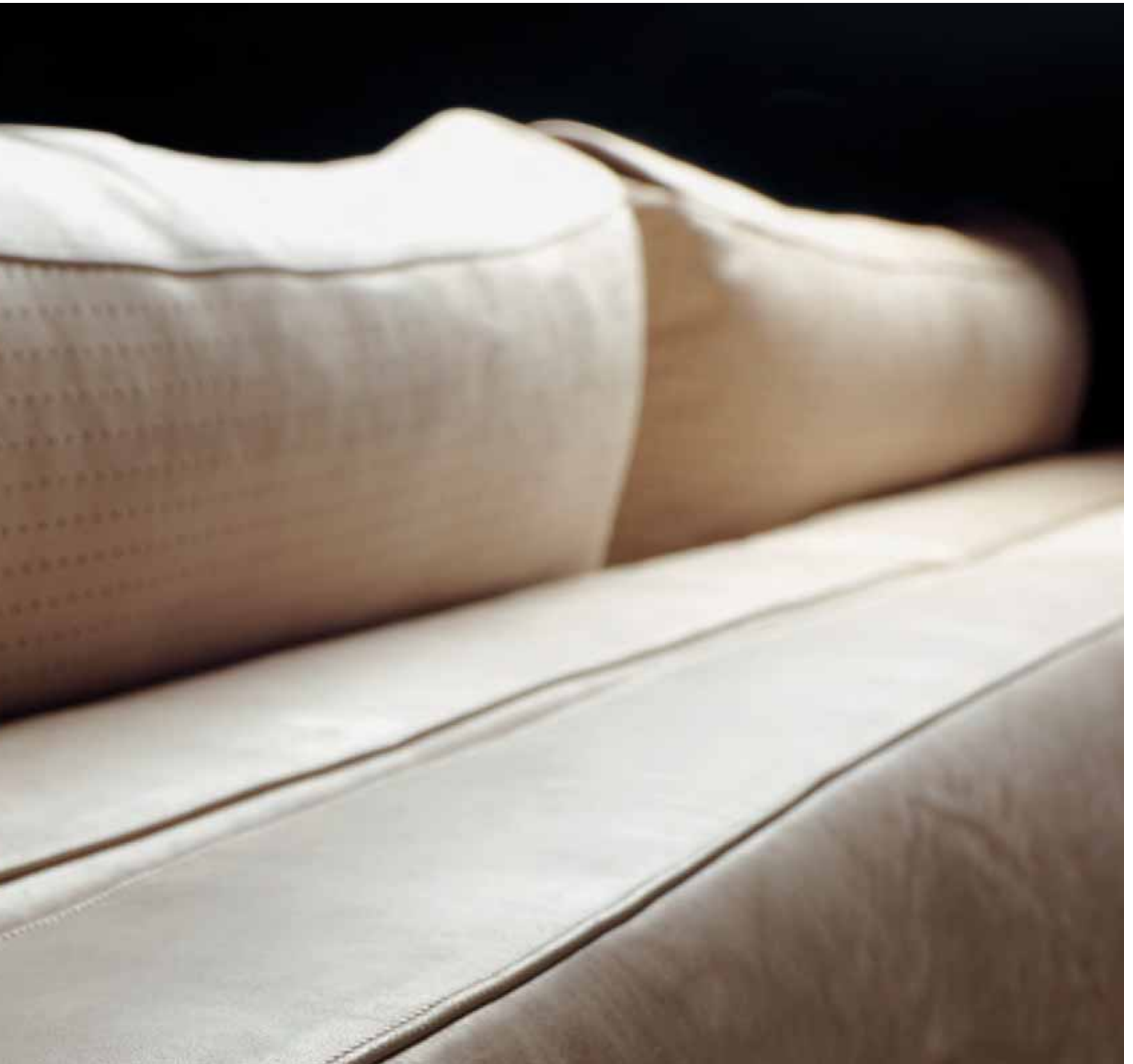

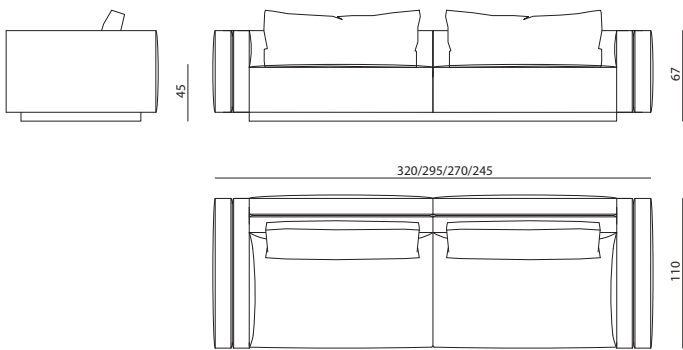

TAYLOR STILL DIVANO  
TAYLOR STILL SOFA

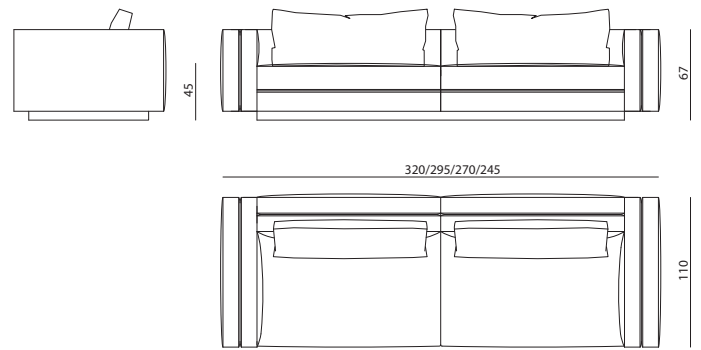

TAYLOR DUAL DIVANO  
TAYLOR DUAL SOFA



## **TAYLOR**

divano\_sofa

design Giuseppe Viganò

Divano tappezzato in pelle o tessuto, con schienale e braccioli a doppio elemento con cuciture ribattute. Scocca interna in legno massello e multistrati, dotata di molleggio a cinghie elastiche. Cuscini di seduta in poliuretano, memory foam® e piuma. Cuscini di schienale e cuscini volanti in poliuretano e piuma. La scocca della seduta è disponibile nella versione Still a singolo elemento e nella versione Dual con base rigida e cuscini in appoggio. Base in legno H.7 cm, rivestita in acciaio inox satinato. Gli elementi componibili offrono diverse possibilità di configurazione integrando gli elementi imbottiti Taylor con gli elementi in legno Agorà nella funzione di tavolini laterali o centrali.

*Upholstered sofa in leather or fabric with twin-element back and arms with riveted seams. Internal shell in solid wood and plywood, equipped with elastic belts springing. Seat cushions in polyurethane, memory foam® and feather. Back cushions and loose cushions in polyurethane and feather. The seat shell is available in the single element Still version and in the Dual version with base and cushions. Wooden base H.7 cm, covered in satin stainless steel. The modular elements offer different configuration possibilities by integrating the Taylor upholstered modular elements with Agorà wooden elements in the function of side or central tables.*





**MIKA**  
*poltroncina\_armchair*



## MIKA

poltroncina\_armchair  
design Giuseppe Viganò

Poltrona tappezzata in pelle o tessuto, con schienale curvo a doppio elemento con cuciture ribattute. Scocca interna in legno massello e multistrati, dotata di molleggio a cinghie elastiche. Seduta in poliuretano, memory foam® e piuma. Cuscini volanti in piuma. Base in legno curvo H.7 cm, rivestita in acciaio inox satinato con meccanismo girevole auto-raddrizzante.

*Upholstered armchair in leather or fabric, with twin-element curved backrest with rivested seams. Inner shell in solid wood and plywood, equipped with elastic belts springing. Seat in polyurethane, memory foam® and feather. Loose cushions in feather. Base in curved wood H.7 cm, covered in satin stainless steel with self-adjusting rotating mechanism.*





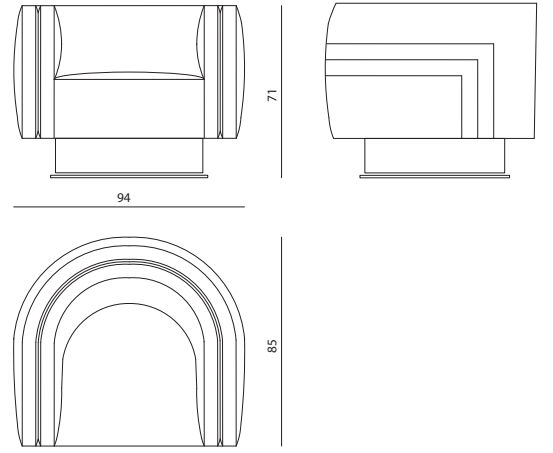



## MARTY

consolle\_console  
design Marco Piva

Consolle in vetro composta da due basamenti rivestiti in specchio bronzo con superficie cannettato in rilievo. Top in cristallo fumè sp. 8 mm scatola tramite incollaggio UV. Ulteriori top di finitura in acciaio inox satinato in corrispondenza delle basi.

*Glass console composed of two bases covered in bronze mirror with embossed surface in relief. Smoked crystal top sp. 8 mm boxed by UV bonding. Additional finishing tops in brushed stainless steel at the bases.*

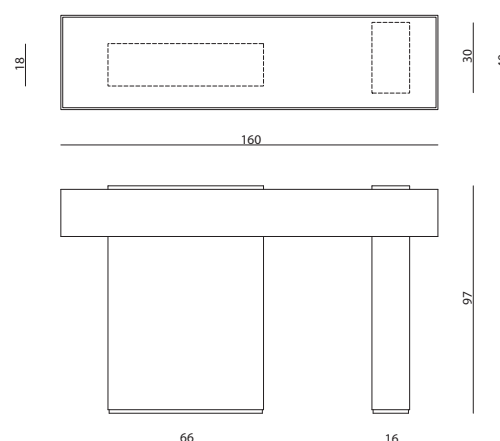



**MARTY**  
*consolle\_console*







**MARTY**  
tavolo basso\_ *low table*





## MARTY

tavolo basso\_low table  
design Marco Piva

Tavolo basso composto da tre basamenti rivestiti in marmo e acciaio inox satinato. Top in cristallo fumè sp. 8 mm scatola tramite incollaggio UV. Ulteriori top di finitura in marmo e acciaio inox satinato a materiali alterni in corrispondenza delle basi.

*Coffee table composed of three bases covered in marble and satin stainless steel. Smoked crystal top sp. 8 mm boxed by UV bonding. Additional finishing tops in marble and stainless steel with alternating materials at the bases.*

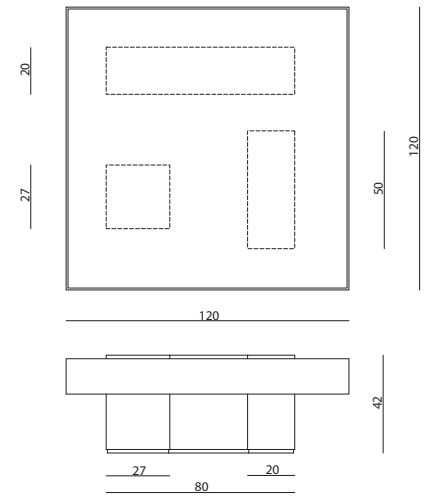



**BRONSON**  
mobile basso\_low cabinet









visionnaire





## BRONSON

mobile basso\_low cabinet  
design Giuseppe Viganò

Mobile basso in legno rivestito in essenza con fianchi sagomati e top centrale in marmo. Quattro ante in essenza e un cassetto con frontale in marmo, maniglie in acciaio satinato. Interno in legno laccato 100 gloss e ripiani in cristallo extrachiaro sp. 8 mm. Cassetto rivestito internamente in microfibra. Base in acciaio inox satinato.

*Low cabinet in veneered wood with shaped sides and marble top. Four doors in wood and a drawer with marble front, handles in satin finish 100 gloss lacquered wood interior and extra-clear glass shelves sp. 8 mm. Drawer internally lined in microfibre. Base in satined stainless steel.*

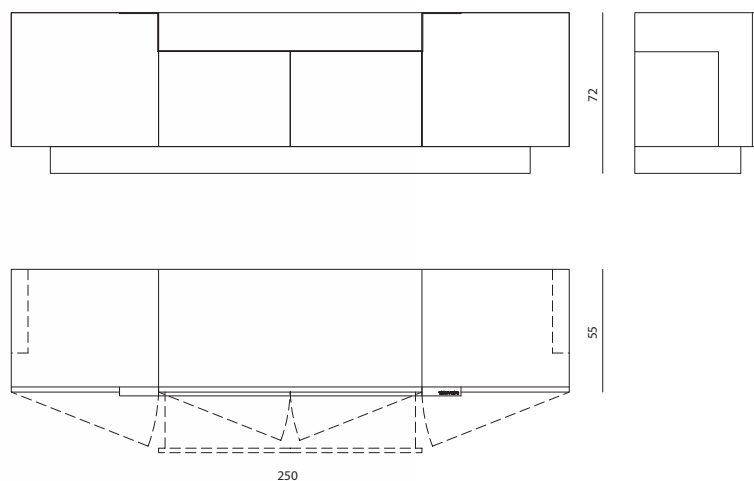

**GAIUS**  
mobile bar\_bar cabinet









visionnaire

## GAIUS

mobile bar\_bar cabinet  
design Giuseppe Viganò

Mobile bar in cristallo fumè scatola tramite incollaggio UV con box interno in legno interamente rivestito in essenza con apertura a ribalta con meccanismo smorzato. Ante laterali in cristallo con maniglie a pendaglio in ottone satinato. Stelo di sostegno in metallo rivestito in essenza e base in acciaio inox satinato.

*Bar cabinet in smoked crystal boxed by UV bonding with internal wooden box completely veneered, with flap opening with damped mechanism. Side crystal doors with frosted brass pendant handles. Support stem in veneered metal and base in brushed stainless steel.*

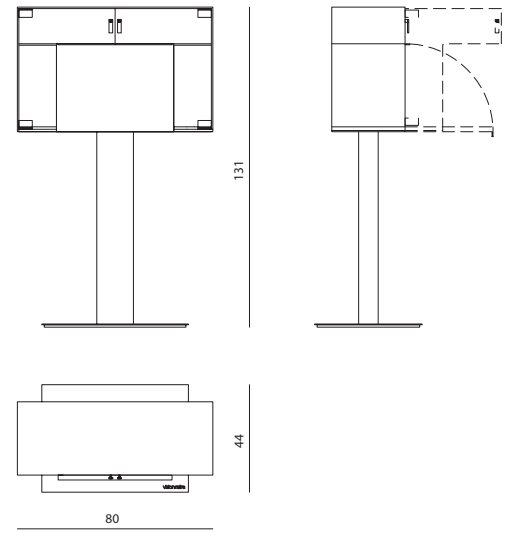





**R I P L E Y**

---

*bed*





## RIPLEY

letto\_*bed*  
design Fabio Bonfà

Letto imbottito con testata trapuntata in pelle o tessuto, incorniciata da un profilo rivestito in pelle o tessuto. Fianchi della testata incassati nella cornice rivestiti in pelle o tessuto intrecciati, leggermente imbottiti. Disponibile con luce di cortesia a LED sui fianchi della testata con interruttori a sfioramento. Sommier in pelle o tessuto intarsiato con profili in ottone sul perimetro del giroletto. Struttura interna in masselli e multistrati di legno, rete a doghe in legno massello. Supporti rete/materasso regolabili in altezza.

*Upholstered bed with quilted headboard in leather or fabric, framed by a profile covered in leather or fabric. Headboard sides embedded in the frame covered in leather or woven, slightly padded. Available with LED courtesy light on the sides of the head with touch switches. Sommier in leather or fabric inlaid with brass profiles around the bed frame. Internal structure in solid and multilayer wood, solid wood slatted base. Height adjustable slats/mattress supports.*





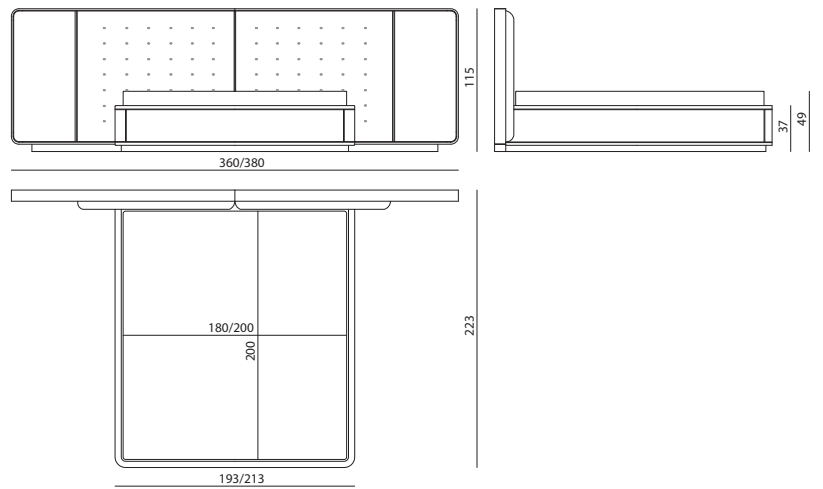



## LEGEND

poltrona\_armchair  
design Fabio Bonfà

Struttura in legno massello e multistrati con molleggio a cinghie elastiche, imbottitura in poliuretano a densità differenziate. Rivestimento in pelle o tessuto. Retro schienale trapuntato. Piedi posteriori rivestiti in pelle o tessuto. Base e piedi anteriori in acciaio inox satinato sono disponibili nella selezione finiture metalliche.

*Structure in solid wood and plywood with elastic straps, padding in polyurethane with different densities. Upholstered in leather or fabric. Quilted backrest. Rear feet upholstered in leather or fabric. Base and front feet in satinized stainless steel available in the metal finishing selection.*

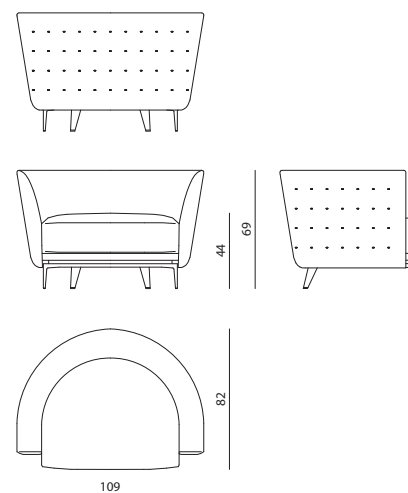

**LEGEND**  
poltrona\_armchair





## JASPER

lampada da tavolo\_ *table lamp*  
design Fabio Bonfà

Lampada da tavolo in ottone massiccio e marmo. Proiettore lineare in ottone contenente una sorgente LED a luce calda da 6W, stelo composto da un doppio tubo di ottone e un elemento conico in marmo massello, base in acciaio satinato.

*Table lamp in solid brass and marble. Linear brass projector containing a 6W LED warm light source, stem consisting of a double brass tube and a conical solid marble element, base in satinized steel.*

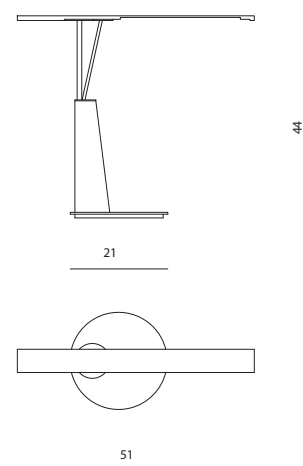



## JASPER

lampada da tavolo\_table lamp





**BARNEY**  
*cassettiera\_chest of drawers*









## BARNEY

cassettiera\_chest of drawers  
design Fabio Bonfà

Cassettiera con 9 cassetti, struttura in mdf rivestita in essenza con inserti in acciaio inox satinato incastonati nel legno, grande maniglione e base in acciaio inox satinato, frontali cassetti in marmo a pieno spessore. Interno laccato opaco, schienale laccato opaco, in opzione disponibile in essenza.

*Chest of 9 drawers, structure in MDF covered in veneer with inserts in satinized stainless steel embedded in the wood, big drawer handle and base in satinized stainless steel, doors in marble in full thickness, mat lacquered internal parts, mat lacquered backrest, available in veneer wood.*

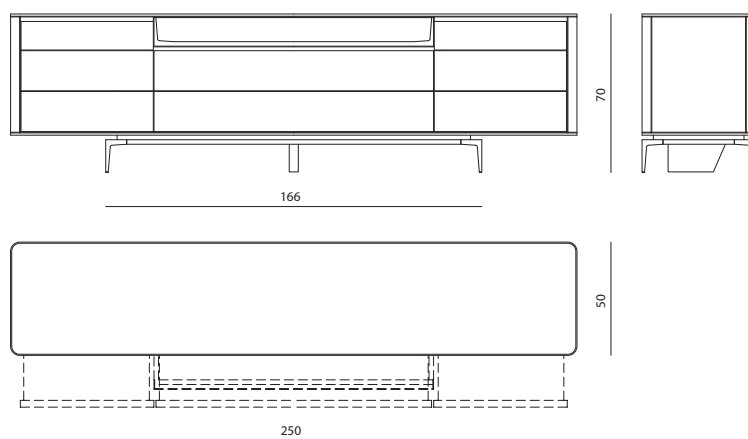



A N A S T A S I A

---

*armchair*



## ANASTASIA

poltroncina\_ *armchair*  
 design Roberto Tapinassi - Maurizio Manzoni

Poltroncina interamente in cuoio spessore 3 mm con inserti spalliera intagliati con motivo gessato. Struttura interna in metallo.

*Armchair entirely in 3 mm thick leather with carved espalier inserts with a pinstripe pattern. Internal metal structure.*

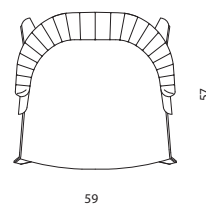
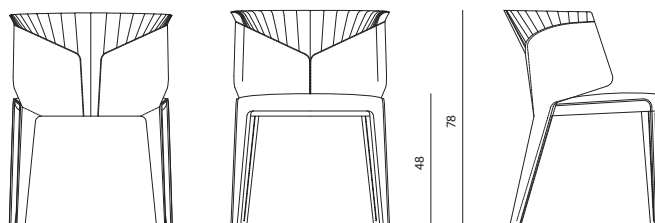



**ANASTASIA**  
*poltroncina\_armchair*





## ANASTASIA

poltrona\_armchair

design Roberto Tapinassi - Maurizio Manzoni

Poltrona interamente in cuoio spessore 3 mm con inserti spalliera intagliati con motivo gessato. Struttura interna in metallo.

Armchair entirely in 3 mm thick leather with carved espalier inserts with a pinstripe pattern. Internal metal structure.

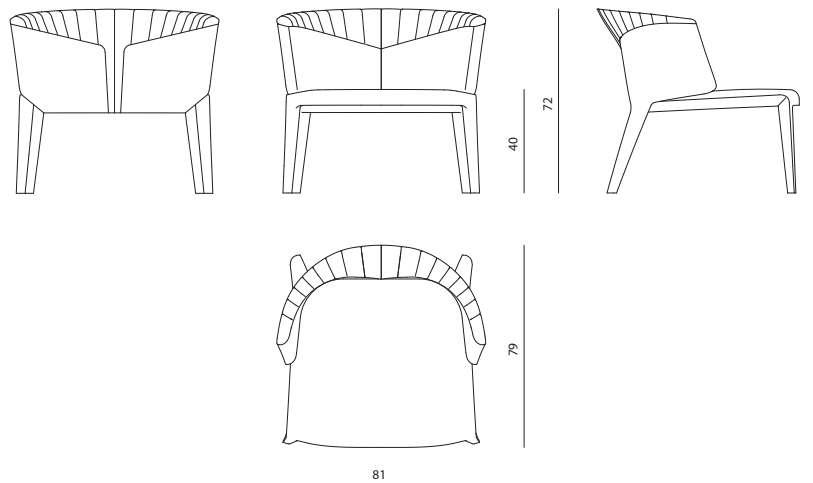



## ANASTASIA

sedia\_chair

design Roberto Tapinassi - Maurizio Manzoni

Sedia interamente in cuoio spessore 3 mm con inserti spalliera intagliati con motivo gessato. Struttura interna in metallo.

*Chair entirely in 3 mm thick leather with carved espalier inserts with a pinstripe pattern. Internal metal structure.*

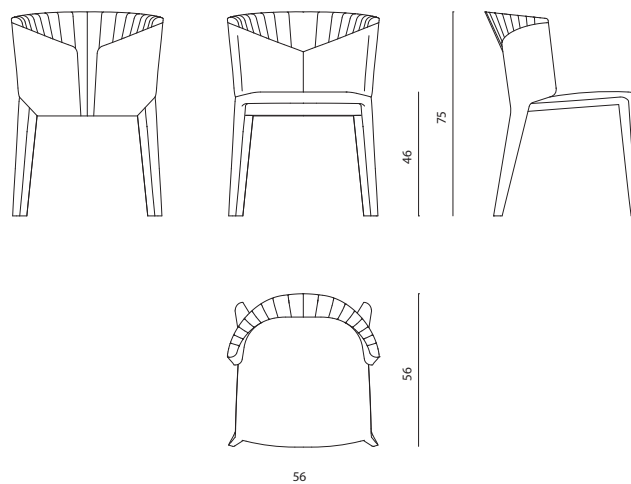







**B A C K S T A G E**

---

*modular sofa*











## BACKSTAGE

divano componibile\_modular sofa





## BACKSTAGE

divano componibile\_modular sofa  
design Fabio Bonfà

Divano componibile tappezzato in pelle o tessuto, con base composta da un telaio in acciaio inox satinato e un pannello in legno e metallo rivestito in pelle o tessuto, dotato di cinghie elastiche per il molleggio dei sedili. Braccioli e schienali caratterizzati da pannelli in legno bordati da un profilo in ottone sp. 10x10 mm tappezzati con pelle, tessuto oppure pelle intrecciata. Cuscini di seduta in poliuretano a diverse densità, memory foam® e piuma. Cuscini di schienale e interno bracciolo in poliuretano e piuma, cuscini volanti in piuma. Disponibile con elementi centrali senza schienale abbinabili alla consolle Banner.

*Modular sofa upholstered in leather or fabric, with base composed of a frame in satinized stainless steel and a panel in wood and metal covered in leather or fabric, equipped with elastic belts for the seats suspension. Armrests and backrests made of a wooden panel edged by a brass profile th. 10x10 mm, and upholstered with leather, fabric or woven leather. Seat cushions in polyurethane with different densities, memory foam® and feather. Back and armrest cushions in polyurethane and feather, loose cushions in feather. Available with central elements without backrest that can be combined with the Banner console.*

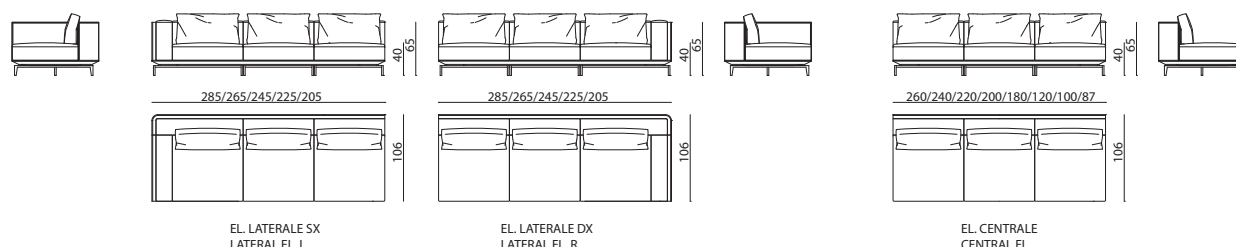

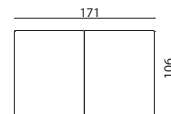
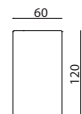
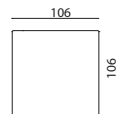
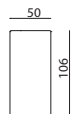
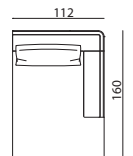
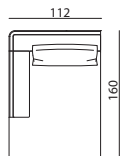
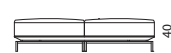
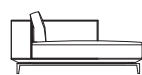
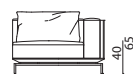
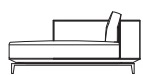

CHAISE-LONGUE SX  
CHAISE-LONGUE L

CHAISE-LONGUE DX  
CHAISE-LONGUE R

BRACCIOLO  
ARMREST

POUFF

POUFF

EL. CENTRALE SENZA SCHIENALE  
CENTRAL EL. WITHOUT BACK







# **B A C K S T A G E**

---

*sofa*











**BACKSTAGE**  
*divano\_sofa*



## BACKSTAGE

divano\_sofa

design Fabio Bonfà

Divano tappezzato in pelle o tessuto, con base composta da un telaio in acciaio inox satinato e un pannello in legno e metallo rivestito in pelle o tessuto, dotato di cinghie elastiche per il molleggio dei sedili. Braccioli e schienali caratterizzati da pannelli in legno bordati da un profilo in ottone sp. 10x10 mm tappezzati con pelle, tessuto oppure pelle intrecciata. Cuscini di seduta in poliuretano a diverse densità, memory foam® e piuma. Cuscini di schienale e interno bracciolo in poliuretano e piuma, cuscini volanti in piuma. Disponibile con elementi centrali senza schienale abbinabili alla consolle Banner.

*Sofa upholstered in leather or fabric, with base composed of a frame in satinized stainless steel and a panel in wood and metal covered in leather or fabric, equipped with elastic belts for the seats suspension. Armrests and backrests made of a wooden panel edged by a brass profile th. 10x10 mm, and upholstered with leather, fabric or woven leather. Seat cushions in polyurethane with different densities, memory foam® and feather. Back and armrest cushions in polyurethane and feather, loose cushions in feather. Available with central elements without backrest that can be combined with the Banner console.*



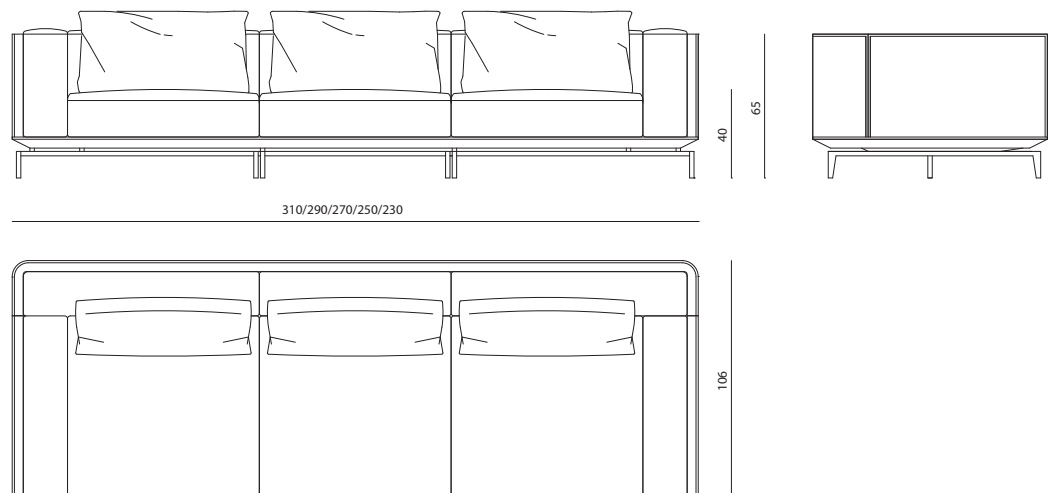



## BANNER

tavolo basso\_low table  
design Fabio Bonfà

Tavolo basso a 4 cassetti in legno scolpito in bassorilievo con disegno a righe, top in marmo. Telaio e profili decorativi in acciaio inox satinato.

*Coffee table with 4 drawers in wood carved in low relief with striped design, marble top. Frame and decorative profiles in brushed stainless steel.*

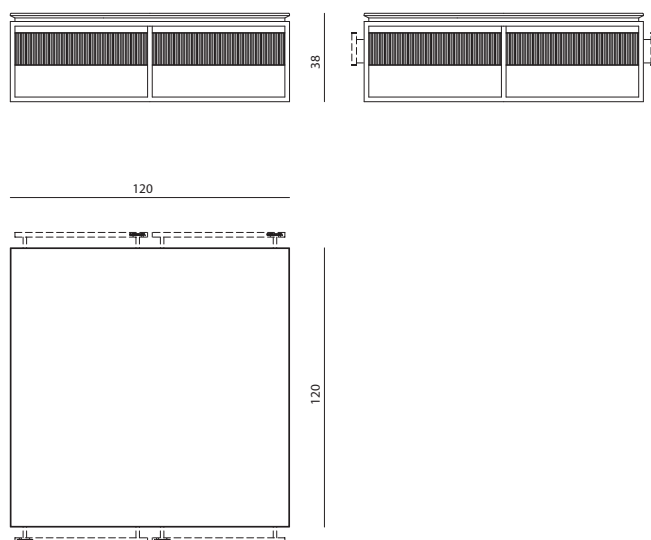



**BANNER**  
tavolo basso\_low table







**BANNER**  
consolle\_console



**BANNER**  
consolle\_console  
design Fabio Bonfà

Consolle a 2 cassetti in legno scolpito in bassorilievo con disegno a righe, top in marmo. Telaio e profili decorativi in acciaio inox satinato, ripiano portariviste in cristallo fumè.

*Console with 2 drawers in wood carved in low relief with striped design, marble top. Frame and decorative profiles in brushed stainless steel, smoked crystal magazine rack.*

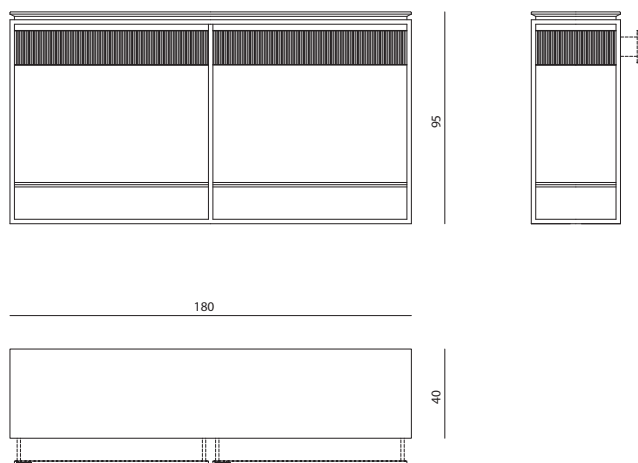





**PARKER**

mobile basso\_ *low cabinet*





## PARKER

mobile basso\_low cabinet  
design Fabio Bonfà

Mobile basso con 4 ante e due cassetti. Struttura in MDF rivestita in essenza con inserti in acciaio inox satinato incastonati nel legno. Ante in legno scolpito in bassorilievo con disegno a rombi, top in marmo. Base con piedi in acciaio inox satinato. Interno laccato opaco, schienale laccato opaco, in opzione disponibile in essenza.

*Low cabinet with 4 doors and two drawers. Structure in MDF covered in wood with inserts in satin stainless steel embedded in the wood. Wooden doors carved in low relief with diamond pattern, marble top. Base with feet in brushed stainless steel, matt lacquered interior, matt lacquered back, optional available veneered.*

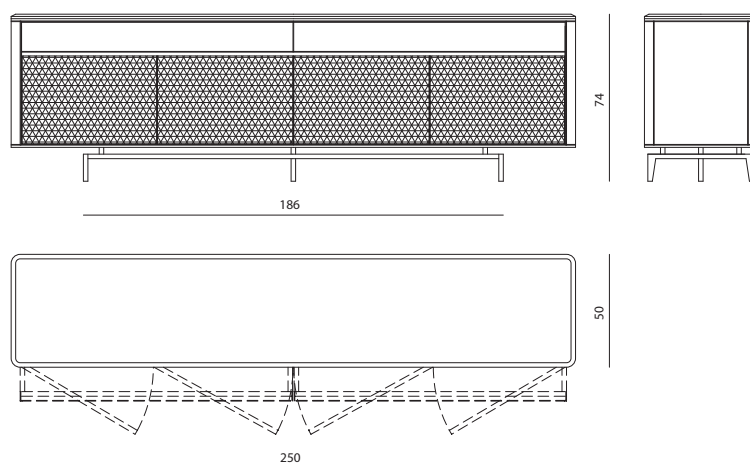







## OMEGA

lampada da tavolo\_ *table lamp*  
design Fabio Bonfà

Lampada da tavolo con diffusore in cristallo molato a mano ad alto spessore, incorniciato da un anello in acciaio sostenuto da due steli in ottone. Base in marmo. Sorgente LED 9W a luce calda.

*Table lamp with diffuser in hand-cut crystal of high thickness, framed by a steel ring supported by two brass stems. Marble base. 9W LED light source with warm light.*

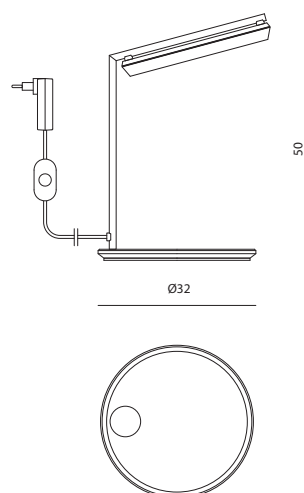



# OMEGA

lampada da tavolo\_table lamp



**POLIDORO**  
specchiera\_mirror



## POLIDORO

specchiera\_mirror  
design Alessandro La Spada

Specchiera con cornice in marmo inserita in un telaio portante in tubolare acciaio inox, specchio bisellato.

*Mirror with marble frame inserted in a supporting frame in tubular stainless steel, bevelled mirror.*

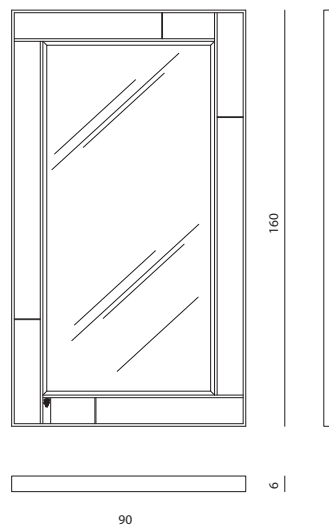





**B A L A N C E**

---

*sofa*





**BALANCE**  
divano\_sofa







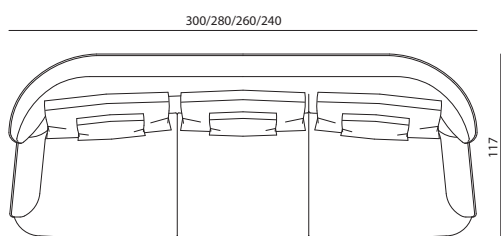
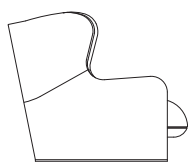
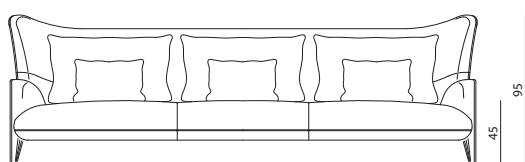



## **BALANCE**

divano\_sofa

design Alessandro La Spada

Divano imbottito in pelle o tessuto. Struttura interna in legno massello e multistrati con molleggio elastico. Scocca e cuscini di seduta imbottiti con rivestimento fisso. Schienale alto e fianchi a bergère. Imbottitura in poliuretano a diverse densità, memory foam® e piuma. Cuscini schienale e cuscini volanti in piuma con retro micro forato. Base rivestita in acciaio inox satinato.

*Upholstered sofa in leather or fabric. Internal structure in solid wood and plywood with elastic suspension. Seat and upholstered seat cushions with fixed cover. High back and bergère sides. Padding in different density polyurethane, memory foam® and feather. Back cushions and down cushions in feather. Base covered in satin stainless steel.*



## BALANCE

poltrona\_ *armchair*  
design Alessandro La Spada

Poltrona imbottita in pelle o tessuto. Struttura interna in legno massello e multistrati con molleggio elastico. Scocca e cuscini di seduta imbottiti con rivestimento fisso. Schienale alto e fianchi a bergère. Imbottitura in poliuretano a diverse densità, memory foam® e piuma. Cuscini schienale e cuscini volanti in piuma con retro microforato. Base rivestita in acciaio inox satinato.

*Upholstered armchair in leather or fabric. Internal structure in solid wood and plywood with elastic suspension. Seat and upholstered seat cushions with fixed cover. High back and bergère sides. Padding in different density polyurethane, memory foam® and feather. Back cushions and down cushions in feather. Base covered in satin stainless steel.*

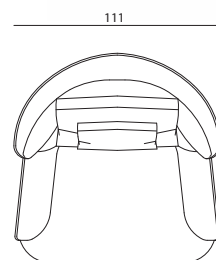
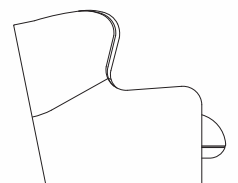
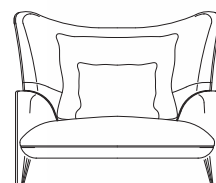



**BALANCE**  
poltrona\_armchair



**ASTRA**  
lampada da tavolo\_table lamp



**ASTRA**

lampada da tavolo\_table lamp  
design Marco Piva

Lampada da tavolo in metallo lucido e vetro soffiato, con paralume conico intagliato a righe orizzontali, con veletta in vetro soffiato. Stelo conico con terminale in vetro soffiato e diffusore satinato contenente 3 sorgenti luminose LED E14 da 6W.

*Table lamp in polished metal and blown glass, with conical lampshade with horizontal stripes, with blown glass veil. Conical stem with blown glass terminal. Satin diffuser containing three 6W LED E14 light sources.*

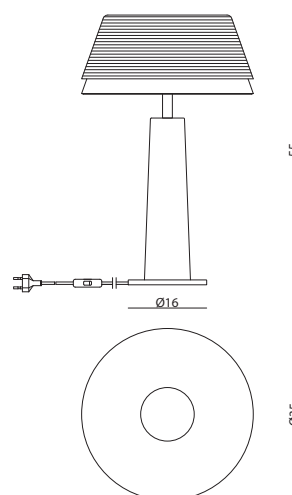



**BALIN - ELMO - GALDOR - TAREG**

*specchio\_mirror*







## BALIN-ELMO-GALDOR-TAREG

specchio\_mirror

design Armando Bruno

Specchio in marmo e vetro accostati a filo, cornice in acciaio satinato. Marmi intarsiati in diverse combinazioni cromatiche.

*Mirror in marble and glass, frame in thin stainless steel, satinized. Marbles inlaid in different colours.*

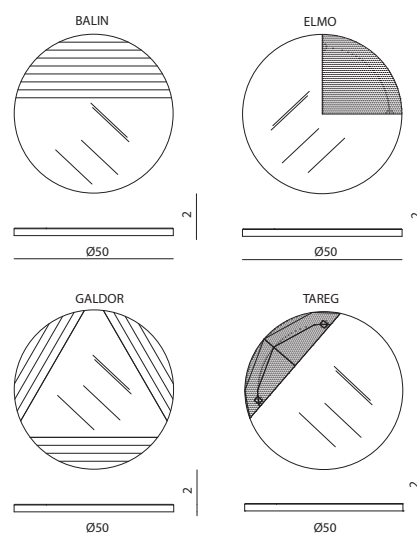



Produced by  
©IPE SRL  
ALL RIGHTS RESERVED

Visionnaire Logo, catalogue and advertising images are sole propriety of IPE srl, henceforth any use of the logo or adaptation of images is strictly forbidden without IPE srl prior approval; nonetheless, in any case the images must be used in such a way that there is no reasonable doubt that those belong to IPE srl and refer to IPE srl products.

No part of this publication can be reproduced or transmitted in any form or by any means, both electronic or mechanical, including photocopying and recording, or via any information storage and retrieval system, without written permission of the publisher. Colours of leather or fabric upholstery, lacquered wood and carpets shall not be considered as colour references. The products dimensions are subject to change according to the catalogue instructions.

Print Made in Italy | APRIL 2018 | by Euroteam

Art Director Eleonore Cavalli

Tutti i colori dei rivestimenti, pelli e tessuti, delle lacche e dei tappeti non possono essere considerati come riferimento colore. Le misure dei prodotti possono subire delle modifiche rispetto alle indicazioni del catalogo.

I.P.E. S.r.l.  
Via Mattei 1 - 40069 Zola Predosa (Bo) Italy  
tel. +39 051 6186311 fax +39 051 6186310  
[www.visionnaire-home.com](http://www.visionnaire-home.com)  
[ipe@ipe.it](mailto:ipe@ipe.it)



