



HOME PHILOSOPHY  
visionnaire

THE ORIGINAL.  
CONCEIVED AND CRAFTED IN ITALY.





THE ORIGINAL.  
CONCEIVED AND CRAFTED IN ITALY.

visionnaire





## RESPIRO

Respiro è ciò che genera la vita e la alimenta, rimanendo intangibile e sottinteso in tutte le cose. Respiro, essenziale per la vita, è ritmo e dinamismo, quello che si crea tra un oggetto e l'altro, tra un oggetto e chi ne beneficia e tra oggetto e spazio circostante.

Il respiro è anche una questione di equilibrio, dando allo spazio la capacità di trasmettere un senso di benessere, di relax, una sensazione che abbiamo voluto ricreare in tutte le aree della casa.

L'attenta ricerca di equilibrio tra materia e forma, tra passato e contemporaneità riportano immediatamente ad ambienti simbolici e meditativi. Pieni e vuoti come diaframmi che ossigenano lo spazio circostante e che trovano la loro espressione e preziosità nei metalli, nelle essenze legnose, nei marmi, così come nella pietra, nel cuoio, nelle lane e nelle raffie ed introducono ad una sensazione di natura in un accordo armonico privo di ridondanza. L'artigianalità è il valore su cui Visionnaire continua a puntare per distinguersi: prodotti con contenuto tecnico sintetizzato in un linguaggio di forte personalità. E se da sempre l'Italia ha rappresentato l'elemento ispiratore per le collezioni, dalla storia dell'arte, al cinema, alle arti visive in generale, quest'anno la direzione creativa guarda con un sapiente e raffinato mix anche ad Oriente.

La palette cromatica attinge alle tonalità dei colori della terra e delle foreste, rendendo così l'elemento naturale il vero protagonista. Una natura simbolica che quest'anno viene suggerita dalla presenza di bambù, emblema di rinascita e potenza energetica.

Una proposta lusso, quindi, che non coincide più solo con l'oggetto di pregio, ma che trova nell'ambiente multisensoriale, nel benessere, nella forza immaginativa e nella convivialità, la risposta all'evoluzione di un mercato in continua trasformazione. Un'eclettica proposta che abbraccia il progetto domestico nella sua interezza: dallo spazio architettonico al più piccolo dettaglio d'arredo. Una soluzione ancora una volta personalizzata, interprete dei sogni e delle aspirazioni di una clientela internazionale alla ricerca di progetti "full home design" ed esclusivamente fatti su misura.

## BREATH

"Respiro" is about seeing what remains unseen, and marks the beginning of everything. "Respiro", as the basis for life, refers to the rhythm and dynamism that exists between objects, between the object and user, and between the object and the surrounding space.

At the heart of "Respiro" lies the aspiration to strike the perfect balance within a space, fostering an oasis of serenity.

The assiduous search for balance between material and shape, between past and present, results in a thoughtful and meditative space. Each piece, like breath oxygenating a space, find their expression in metal, wood and marble, in stone, leather, wool and raffia, ushering in the sensation of nature in harmonious arrangement, devoid of excess. Exquisite craftsmanship remains the defining value upon which Visionnaire stands: products with technical content executed with style and a strong personality. Though Italy's rich history of art, cinema and the visual arts have always provided a deep well of inspiration, this year the creative direction also turns to the East, creating an elegant and refined mix.

The colour palette draws from the nuanced tones of the earth and forests, rendering the natural element the true protagonist, and this year, bamboo provides the symbolism of rebirth and potential energy.

A luxury offering, therefore, that no longer exists only as an object of merit, but which finds, in the multi-sensory experience a well-being, an imaginative strength and conviviality. In response to the continually evolving market, the collection provides an eclectic selection able to transform any project in its entirety: from architectural elements to small furnishing details. A bespoke solution custom designed to interpret the dreams and aspirations of an international clientele in pursuit of a complete home design and exclusively made-to-measure projects.



**Babylon**  
Chaise longue

**Stinger**  
Tavolo basso - *Low table*

**Tea-Party**  
Consolle - *Console*

**Akira**  
Applique - *Wall lamp*

**Serpente**  
Scultura - *Sculpture*

**Akira**  
Lampada da tavolo - *Table lamp*







# RESPIRO

“呼吸”(Respiro) 就是指领会一些看不见的东西, 以及在每件事情的开端留下记号。“呼吸”(Respiro) 作为生命的基本要素, 指的是物体之间、物体和使用者之间和物体和周围空间之间存在的节奏和活力。在“呼吸”(Respiro)的深处藏着在一个空间内达到完美平衡的愿望, 并培育一个平静安详的绿洲。

努力寻找物质和形状之间、过去和现在之间的平衡, 带来静思和冥想的空间。每一件作品, 正如在一呼一吸之间使周围空间充满氧气, 在金属、珍珠和大理石、石头、皮革、羊毛和酒椰中找到它们的表达方式, 并将自然的感觉带入和谐的协调之中, 不多不少。精湛的工艺是Visionnaire不断追求并独树一帜的价值—即生产具有强烈个性、富含多种技巧的产品。虽然意大利在艺术、电影和视觉艺术上拥有的浓厚历史一直带来丰富的灵感元素, 今年的创意方向却转向东方元素, 打造一个优雅和精致的组合。整体色调汲取了大地和森林的颜色, 从而使自然元素成为真正的主角, 而今年采用的竹艺象征着重生和潜藏的活力。因此, 如此奢华的出品不再仅仅是具有价值的东西, 而是能在多重感官体验中发现福祉、想象力和欢乐。面对持续变化的市场, 该系列提供一个兼收并蓄的选择, 从而能够在任何的设计项目进行整体上的转变—从建筑元素到最小的装饰细节。量身定制的解决方案能诠释国际客户的梦想和愿望, 就是寻求十全十美的家居设计和专门的量身定制项目。

# RESPIRO

Идея «Respiro» – в том, чтобы разглядеть то, что остается недоступным глазу, чтобы обозначить начало всему сущему. Само слово «Respiro», то есть «дыхание», относится к ритму и динамике, возникающим между разными объектами, между объектом и пользователем, между объектом и окружающей средой. В основе концепции «Respiro» лежит стремление добиться идеального баланса в пространстве, создать оазис безмятежности. Неослабный поиск равновесия между материалом и формой, прошлым и настоящим, порождает среду, способствующую размышлению и созерцанию. Подобно дыханию, насыщающему кислородом пространство, каждый предмет коллекции обретает воплощение в металле, дереве и мраморе, в камне, коже и рафии, рождая ощущение гармоничного устройства мироздания, чуждого крайностей. Превосходное качество исполнения остается основополагающей чертой Visionnaire: изделия с техническим контентом выполнены со стилем и яркой индивидуальностью. На протяжении всей богатой истории искусств в Италии кинематограф и изобразительное искусство всегда служили неисчерпаемым источником вдохновения для творчества, а в этом году внимание дизайнеров также привлек восток, что позволило создать элегантный и изысканный коктейль. Цветовая гамма коллекции опирается на богатые оттенками тона земли и леса, превращая природу в полноценного героя повествования; в этом году в качестве символа возрождения и потенциальной энергии выступает бамбук. Таким образом, предлагаемые изделия из обычных объектов роскоши превращаются в оживляемое силой воображения воплощение благополучия и праздничного настроения. В соответствии с запросами непрерывно развивающегося рынка, коллекция предлагает эклектичный выбор товаров, позволяющих полностью изменить лицо любого проекта, начиная с архитектурных элементов и заканчивая мелкими деталями мебелировки. Решения под заказ воплощают в себе мечты и пожелания клиентов со всего мира, желающих достичь завершенности дизайна интерьера и реализовать эксклюзивные индивидуальные проекты.



Wunjo  
Poltrona - *Armchair*

Sowilo  
Tavolo basso - *Low table*

Aurora  
Consolle - *Console*

Kenaz  
Tavolo basso - *Low table*



Wunjo  
Poltrona - *Armchair*

Sowilo  
Tavolo basso - *Low table*

Brunilde  
Applique - *Wall lamp*



### 01. WUNJO

Poltrona cm 110x98 H.129. Scocca in tessuto Chardin 24238/10, seduta in tessuto Bosch 24237/10, particolare bracciolo in Agata naturale blu. Cuscino di schienale in tessuto Ingres 24239/10, filetti e piedi posteriori in pelle Soft Leather Beola, piedi anteriori in metallo nichel nero satinato.

*Right armchair cm 110x98 H.129. Main upholstery in fabric Chardin 24238/10, seat in fabric Bosch 24237/10. Armrest detail in natural blue Agatha. Cushion in fabric Ingres 24239/10, pipings in Soft Leather Beola, front feet in satin black nickel metal.*

### 02. SOWILO

Tavolino ellittico cm 150x75 H. 38. Base in manganese, cornice top e profilo di base in acciaio nichel nero satinato, top in marmo Invisible Grey.

*Elliptical low table cm 150x75 H.38. Base in Manganese finishing. Top in marble Invisible Grey. Top profile in satinized stainless steel black nickel finishing.*

### 03. KENAZ

Tavolino tondo cm Ø48 H.64. Struttura in metallo nichel nero satinato, piano in legno laccato Ral 9005. Top a incasso in Agata naturale.

*Round table cm Ø48 H.64. Structure in black nickel lacquered aluminum, top in natural Agatha.*

### 04. AURORA

Consolle a 3 cassetti cm 163x45 H.98. Struttura e gambe in acciaio nichel nero satinato. Parti in legno laccato nero opaco. Frontali cassetti in Agata Naturale. Profili in acciaio nichel nero satinato.

*Console with 3 drawers cm 163x45 H.98. Top and legs in satin black nickel metal. Drawers in natural Agatha. Steel profiles in satin black nickel finishing.*

### 05. BRUNILDE

Applique cm 40x36 H.159. Corpo in ottone nichel nero lucido. Paralume ovale in tessuto Ingres 24239/10.

*Wall lamp cm 40x36 H.159. Body in black nickel. Lampshade in fabric Ingres 24239/10.*

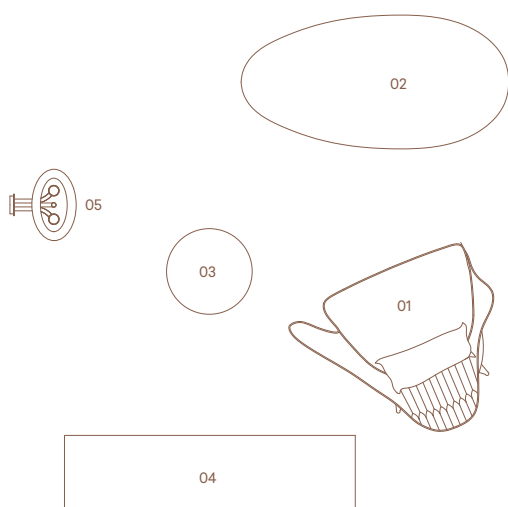

### 01. BABYLON

Chaise longue destra cm 177x112 H.64. Rivestimento in pelle Levante 24278/37 Oltremare, profili ed inserti in acciaio champagne satinato. Cuscino volante con fascetta cm 40x40 in tessuto Tropical 24274/01 Verde.

*Right chaise-longue cm 177x112 H.64. Main upholstery in leather Levante 24278/37 Oltremare, profiles and plates in satin champagne metal. Loose cushion cm 40x40 in fabric Tropical 24274/01 Verde.*

### 02. STINGER

Tavolino cm 58x48 H.61. Top e base inferiore in pelle Cordoba 24279/57 Mirto con trapuntatura canettata, parti in acciaio champagne satinato.

*Low table cm 58x48 H.61. Upholstery in leather Cordoba 24279/57 Mirto with cannetè quilting, side covered in satinized champagne lacquered steel.*

### 03. TEA PARTY

Consolle cm 160x54 H.85. Struttura acciaio nichel nero satinato, top in legno massello a doghe in finitura MAS-4. Piatto decorativo in marmo Carrara.

*Console cm 160x54 H.85 with solid wood stripes, painted MAS-4, structure in satinized black nickel lacquered steel, decorative plate in Carrara marble.*

### 04. MINSTREL

Tavolino cm 42x39 H.52. Corpo centrale in legno C.510 radica eucalipto frisè, base in acciaio champagne satinato.

*Coffee table cm 42x39 H.52. Structure in wood covered in veneer C.510 eucalipto frisè with polished finish, base in satinized champagne lacquered steel.*

### 05. AKIRA

Applique a 2 bracci cm 60x55 H.60. Struttura in ottone oro lucido. Paralumi in seta a stampa floreale e interno in tessuto moirè.

*Wall lamp cm 60x55 H.60. Structure in polished golden brass. Fan-shaped lampshades in silk with floral print and inside in moiré fabric.*

### 06. AKIRA

Lampada da tavolo cm 42x11 H.62. Paralume in seta con disegno Tropical, struttura in ottone champagne satinato.

*Table lamp cm 42x11 H. 62. Lampshade in silk with Tropical print, structure in satin champagne brass.*

### 07. SERPENTE

Ceramica smaltata nichel nero.

*Glazed ceramic black nickel.*

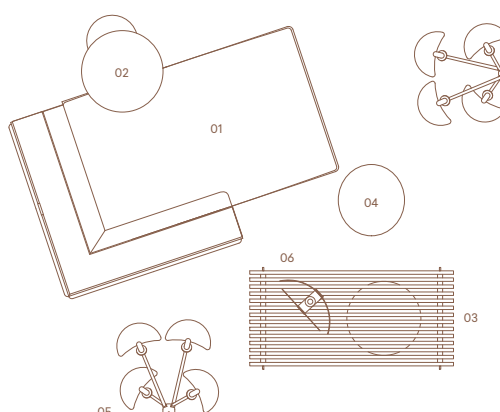

- 015 ENTRANCE
- 023 BASTIAN Living Room
- 041 OPERA Dining Room
- 063 XAVIER Living Room
- 091 KERWAN Dining Room
- 125 EMOTION Bedroom
- 145 HARMONY Wellness
- 153 KATHRYN Outdoor
- 171 RÊVERIE Bedroom
- 195 KOBOL Wellness
- 209 JASON Dining Room
- 239 BALANCE Living Room
- 273 RIPLEY Bedroom
- 303 BACKSTAGE Living Room
- 331 TAYLOR Living Room
- 345 TECHNICAL BOOK

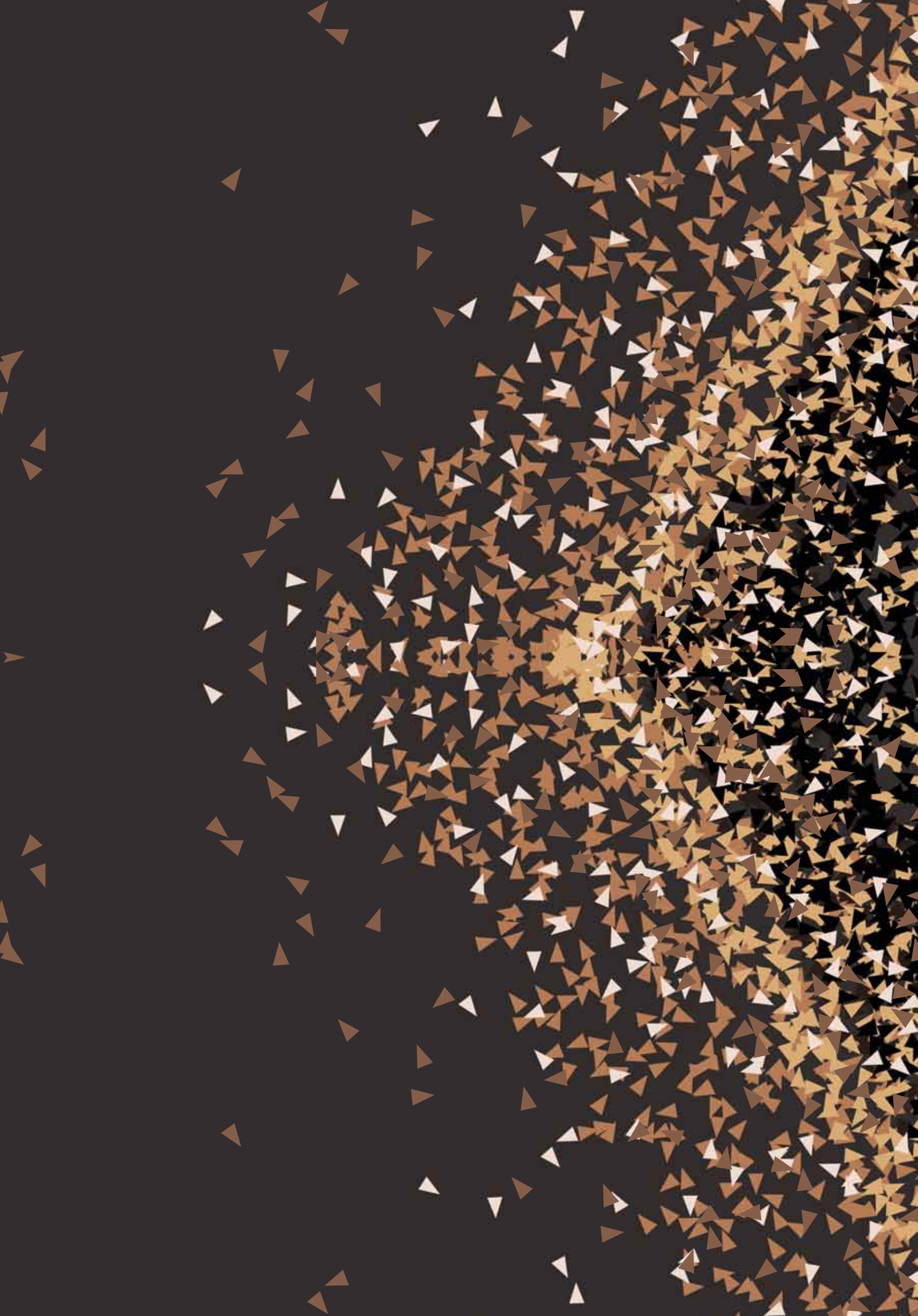



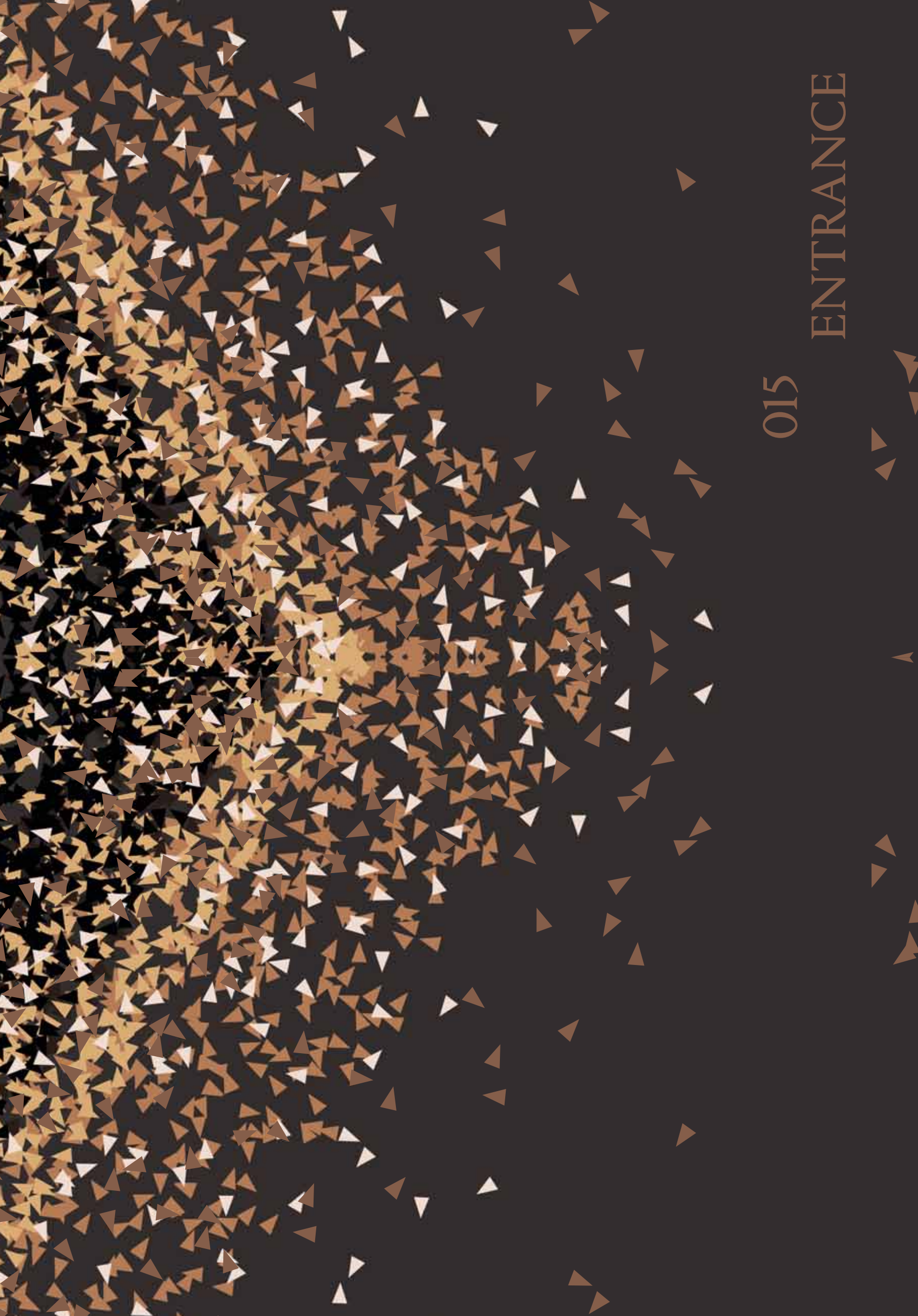

015

ENTRANCE









RAIDHO  
Tavolo da pranzo - *Dining table*





### 01. RAIDHO

Tavolo da pranzo cm Ø180 H. 77. Top in marmo intarsiato con disegno composto da: Mystic brown, Arabescato Orobico Grigio, Rosso Levanto Turco. Sottotop in legno tornito laccato lucido RAL 7022. Basamento acciaio nichel nero lucido.

*Dining table diam. cm 180 H. 77. Top in 3 inlaid marbles: Mystic brown, Arabescato Orobico Grigio, Rosso Levanto Turco. Under top in laquered wood RAL 7022. Base in black nickel metal.*

### 02. HAMMOND

Plafoniera cm Ø100 H.260. Struttura in acciaio e ottone placcato oro lucido con grappoli di pendenti in vetro ambra.

*Ceiling lamp cm Ø100 H.260. Structure in gold plated metal with amber glass pendants.*

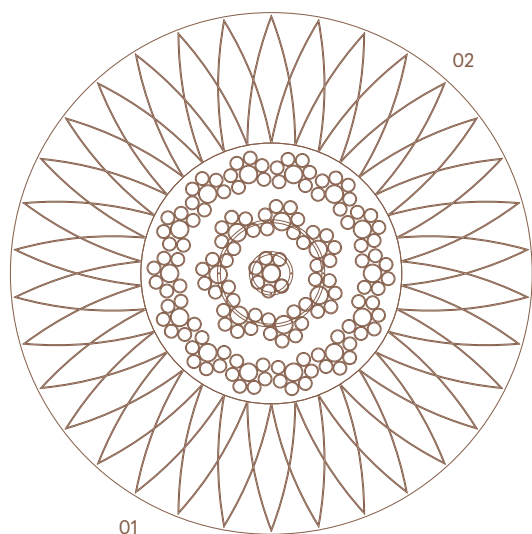





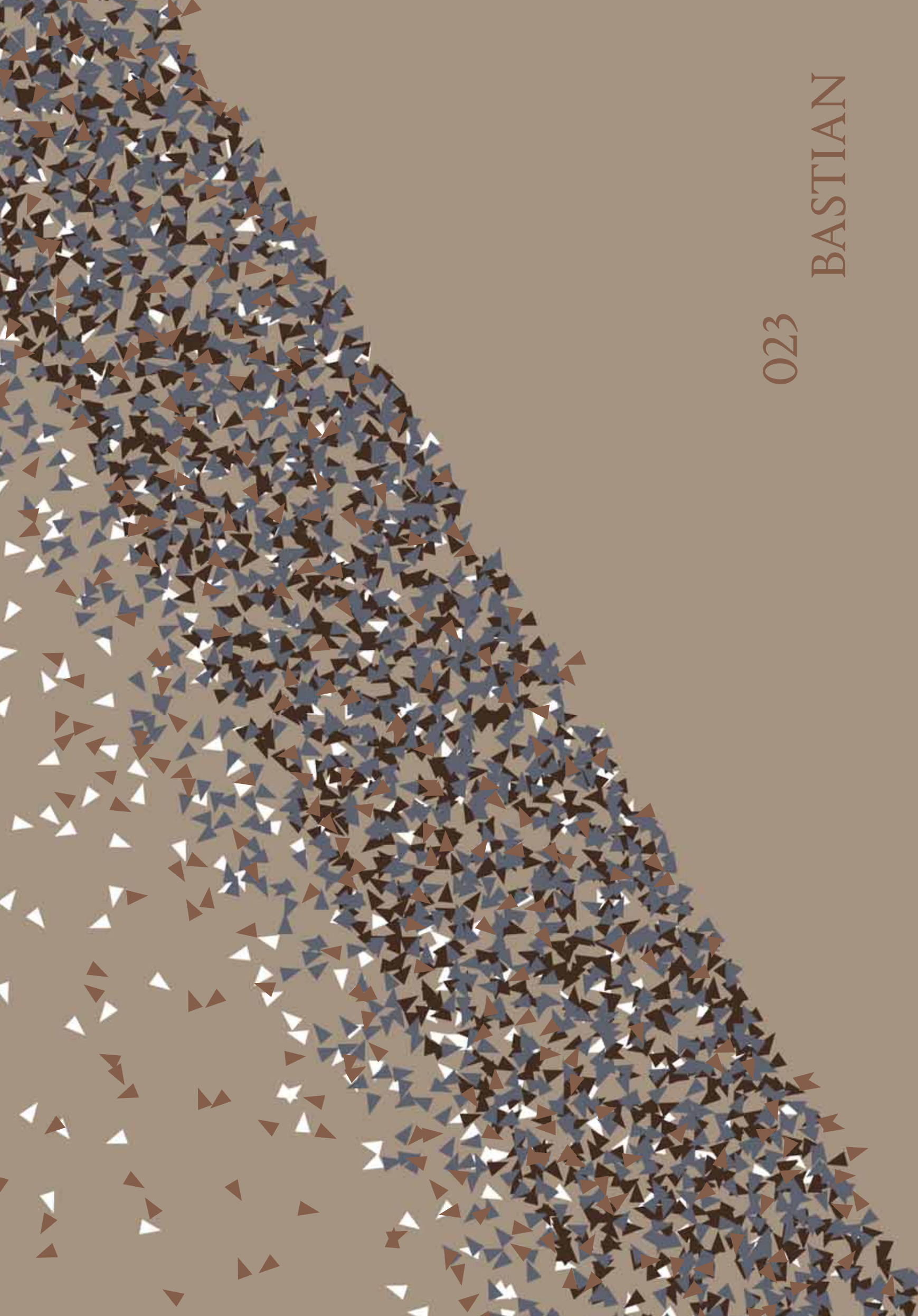

023

BASTIAN



**BASTIAN-DUAL**  
Divano componibile - *Modular sofa*

**BASTIAN-STILL**  
Divano - *Sofa*

**AURYN**  
Tavolo basso - *Low table*

**GALDOR, BALIN, ELMO, TAREG**  
Specchi - *Mirrors*



**BRANDO**  
Lampadario - *Chandelier*

**ELDER**  
Piantana - *Floor lamp*















**ELDER**  
Piantana - *Floor lamp*

**BASTIAN-STILL**  
Pouf - *Pouffe*

**ATREYU**  
Tavolo basso - *Low table*





**EQUINOX**  
Consolle Bar - *Bar unit*

**ELDER**  
Lampada da tavolo - *Table lamp*

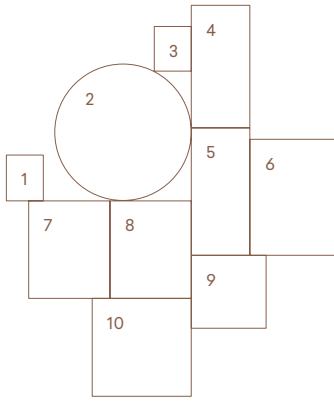

## ART GALLERY

### CaCO3 - composizione 10 pezzi

### CaCO3 - set of 10 pieces

1. Movimento n.108 cm 28x23x4: Pasta vitrea con foglia d'oro bianco, ossido minerale e malta su multistrato, ferro.

1. Movimento n.108 cm 28x23x4: vitreous paste with white golden leaf, mineral oxide and mortar. Iron frame.

2. Aggregato n.10 cm Ø81,5x4: Malta su multistrato, ferro.

2. Aggregato n.10 cm Ø81,5x4: mortar. Iron frame.

3. Movimento n.132 cm 28x23x4: Pasta vitrea, ossido minerale e malta su multistrato.

3. Movimento n.132 cm 28x23x4: vitreous paste, mineral oxide and mortar.

4. Soffio n. 16 cm 75x35x4: Pasta vitrea con foglia d'oro bianco e malta su pannello alveolare, ferro.

4. Soffio n. 16 cm 75x35x4: vitreous paste with white golden leaf, mineral oxide and mortar. Iron frame.

5. Soffio n. 17 cm 75x35x4: Pasta vitrea con foglia d'oro bianco e malta su pannello alveolare, ferro.

5. Soffio n. 17 cm 75x35x4: vitreous paste with white golden leaf, mineral oxide and mortar. Iron frame.

6. Alveolizzazione n.7 cm 70x50x5: Gesso e malta su popolit.

6. Alveolizzazione n.7 cm 70x50x5: plaster and mortar on popolit.

7. Soffio n. 20 cm 60x50x4: Vetro, ossido minerale e malta su pannello alveolare, ferro.

7. Soffio n. 20 cm 60x50x4: glass, mineral oxide and mortar. Iron frame.

8. Soffio n. 21 cm 60x50x4: Vetro, ossido minerale e malta su pannello alveolare, ferro.

8. Soffio n. 21 cm 60x50x4: glass, mineral oxide and mortar. Iron frame.

9. Movimento n. 21 cm 45,6x45,6x4: Calcare nero, ossido minerale e malta su multistrato, ferro.

9. Movimento n. 21 cm 45,6x45,6x4: black limestone, mineral oxide and mortar. Iron frame.

10. Soffio n. 15 cm 60x60: Calcare, malta e stucco su pannello alveolare, ferro.

10. Soffio n. 15 cm 60x60: limestone, mortar and stucco. Iron frame.

## EQUINOX

Consolle Bar - Bar unit

## ELDER

Lampada da tavolo - Table lamp







GALDOR,  
BALIN,  
ELMO,  
TAREG  
Specchi - Mirrors







## 01. BASTIAN-DUAL

Divano componibile: un elemento centrale destro senza bracciolo cm 231x95 H.78 (BDUCR36), un elemento laterale sinistro cm 268x95 H.78 (BDUCL21), un tavolino/bracciolo imbottito sagomato sinistro cm 35x82 H.45 (BBL108), una chaise-longue destra cm 158x95 H.78 (BDCLR125). Rivestimento pelle Taras Leather 24296/36 Sabbia con filetti e fettucce in Nabuk Maestrale 24127/3414 Talpa. Battitacco, mostrine laterali e posteriori in acciaio nichel nero satinato. Due cuscini volanti cm 40x40 in tessuto Cinthia 24277/13 Sabbia, filetti Nabuk Maestrale 24127/3414 Talpa.

*Modular sofa: central right element cm 231x95 H.78 (BDUCR36), side left element cm 268x95 H.78 (BDUCL21), left table/armrest cm 35x82 H.45 (BBL108), Right chaise longue cm 158x95 H.78 (BDCLR125). Main upholstery in Taras Leather 24296/36 Sabbia, pipings in leather Nabuk Maestrale 24127/3414 Talpa. Friezes in satin black nickel metal. Two loose cushions cm 40x40 in fabric Cinthia 24277/13 Sabbia, pipings in leather Nabuk Maestrale 24127/3414 Talpa.*

## 02. BASTIAN-STILL

Divano cm 280x95 H.78 con schienale doppio. Rivestimento in pelle Cordoba 24279/09 Perla con filetti e fettucce in Nabuk Maestrale 24127/3408 Silver. Battitacco, mostrine laterali e posteriori in acciaio nichel nero satinato. Due cuscini volanti cm 40x40 in tessuto Falcade 24276/05 Betulla. Due cuscini volanti cm 40x40 in tessuto Vermeer 24175/111 Peltro, filetti in Cordoba 24279/09 Perla.

*Sofa cm 280x95 H.78. Main upholstery in leather Cordoba 24279/09 Perla, pipings in Nabuk Maestrale 24127/3408 Silver. Friezes in satin black nickel metal. Two loose cushions cm 40x40 in fabric Falcade 24276/05 Betulla. Two loose cushions cm 40x40 in fabric Vermeer 24175/111 Peltro with pipings in leather Cordoba 24279/09 Perla.*

## 03. AURYN

Tavolino cm 35x64 H.45. In legno C.902 Sicomoro Frisè e rivestimento in pelle Cordoba 24279/09 Perla.

*Low table cm 36x64 H.45. Body in veneered wood C.902 Sycomore frisè and leather Cordoba 24279/09 Perla.*

## 04. ATREYU

Tavolino cm 120x60 H.44. Struttura in acciaio nichel nero satinato, top in marmo Arabescato Vagli.

*Low table cm 120x60 H.44. Structure in satin black nickel lacquered steel, top in Arabescato Vagli marble.*

## 05. BASTIAN-STILL

Pouf cm 92x92 H.38. Rivestimento in pelle Cordoba 24279/09 Perla, filetti in Nabuk Maestrale 24127/3408, mostrine laterali in acciaio nichel nero satinato.

*Pouffe cm 92x92 H.38. Upholstery in leather Cordoba 24279/09 Perla with pipings in leather Nabuk Maestrale 24127/3408. Friezes in satin black nickel metal.*

## 06. ELDER

Lampada da tavolo cm Ø45 H.59. Struttura in acciaio nichel nero satinato; base in marmo Silverwave. Paralume traforo intreccio Theride mod. R11675 pelle Bufalo Cioccolato.

*Table lamp cm Ø45 H.59. Structure in satin black nickel steel with, base in Silverwave marble. Lampshade in leather interwoven Theride mod. R11675 Bufalo Cioccolato.*

## 07. ELDER

Lampada da terra cm Ø45 H.168. Struttura in acciaio nichel nero satinato; base in marmo Silverwave. Paralume traforo intreccio Theride mod. R11675 pelle Bufalo Cioccolato.

*Floor lamp cm Ø45 H.59. Structure in satin black nickel steel with base in Silverwave marble. Lampshade in leather interwoven Theride mod. R11675 Bufalo Cioccolato.*

## 08. EQUINOX

Consolle bar cm 270x50 H.80. Scocca con top a ribalta apribile in legno laccato Ral 7022 lucido. Struttura portante in acciaio nichel nero satinato. Interno mobile laccato RAL 7022 opaco con ripiani in cristallo fumè e fondo in specchio fumè. Pannello frontale in marmo Arabescato Vagli con fregio in acciaio nichel nero satinato e inserti in pelle Taras Leather 24296/36 Sabbia. Impianto audio bluetooth disponibile su richiesta.

*Bar unit cm 270x50 H.80. Top in glossy lacquered wood RAL 7022, front in Arabescato Vagli marble with inserts in steel and leather Taras 24296/36 Sabbia, internal in RAL 7022 half-glossy wood, bottom in smoked mirror and internal shelves in crystal. Structure in satin black nickel steel. Optional: Bluetooth audio system.*

## 09. BRANDO

Lampadario rettangolare cm 156x53 H.60. Struttura portante in acciaio e ottone nichel nero satinato. Paralumi in marmo Onice Ivory.

*Rectangular chandelier cm 156x53 H.60. Structure in satin black nickel brass. Lampshades in Ivory onix marble.*

## 10. CONWAY

Tappeto cm 400x300.  
Carpet cm 400x300.

## 11. GALDOR

Specchio cm Ø50. Cornice perimetrale acciaio nichel nero satinato. Inserti in marmo Nero Marquina, Arabescato Vagli, Grigio Bardiglio.

*Mirror cm Ø50. Frame in satin black nickel steel. Inserts in nero Marquina, Arabescato Vagli, Grigio Bardiglio marble.*

## 12. BALIN

Specchio cm Ø50. Cornice perimetrale acciaio nichel nero satinato. Inserti in marmo Nero Marquina, Arabescato Vagli.

*Mirror cm Ø50. Frame in satin black nickel steel. Inserts in nero Marquina, Arabescato Vagli marble.*

## 13. TAREG

Specchio cm Ø50. Cornice perimetrale acciaio nichel nero satinato. Inserti in marmo Nero Marquina.

*Mirror cm Ø50. Frame in satin black nickel steel. Inserts in nero Marquina marble.*

## 14. TAREG

Specchio cm Ø50. Cornice perimetrale acciaio nichel nero satinato. Inserti in marmo Arabescato Vagli.

*Mirror cm Ø50. Frame in satin black nickel steel. Inserts in Arabescato Vagli marble.*

## 15. ELMO

Specchio cm Ø50. Cornice perimetrale acciaio nichel nero satinato. Inserti in marmo Arabescato Vagli.

*Mirror cm Ø50. Frame in satin black nickel steel. Inserts in Arabescato Vagli marble.*

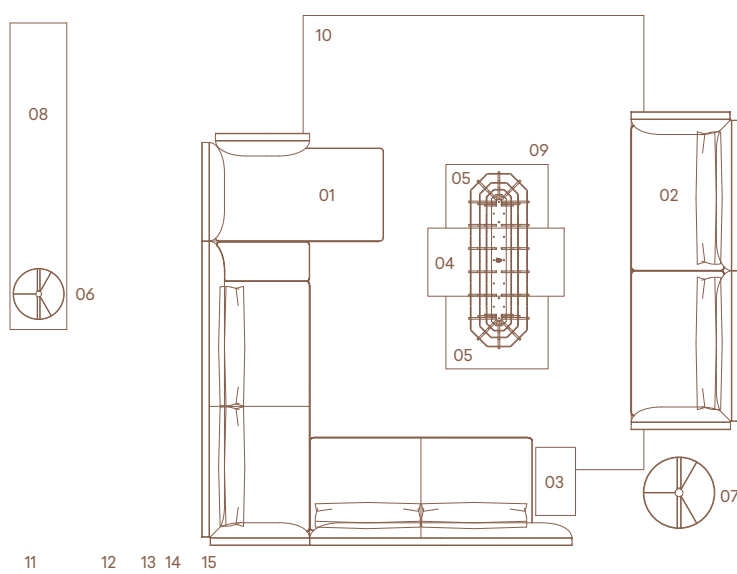



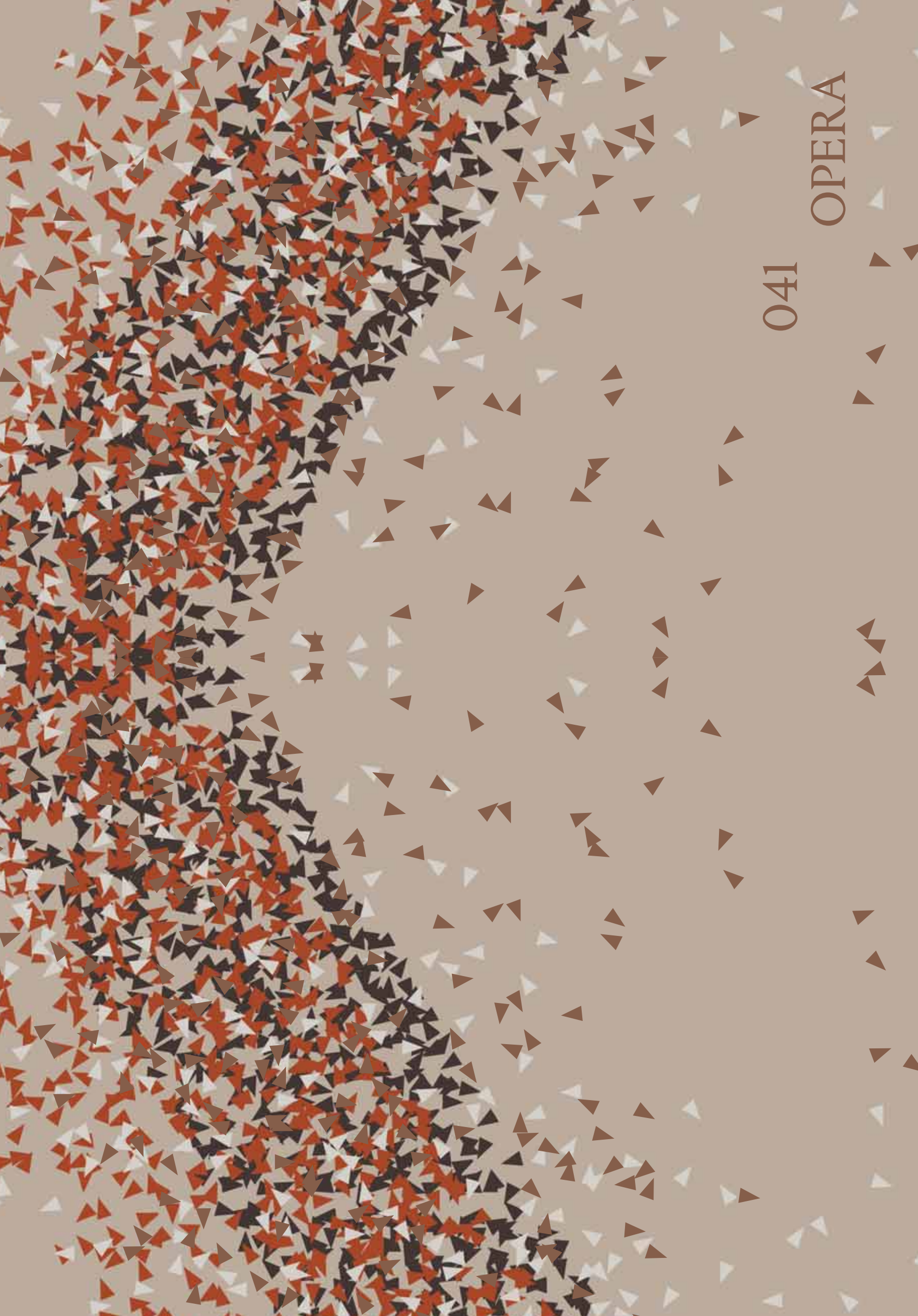

041

OPERA



**OPERA**  
Tavolo da pranzo - *Dining table*

**CARMEN STEEL**  
Sedia - *Chair*

**CARMEN PADDED**  
Sedia - *Chair*



**ETHAN**  
Lampadario - *Round chandelier*

**AZIMUT**  
Consolle - *Console*

**BELAR**  
Tappeto - *Carpet*











**CARMEN STEEL**  
Sedia - *Chair*

**AZIMUT**  
Mobile con ante - *Cabinet*

**FLAMINGOS**  
Art gallery

**STILO**  
Lampada da tavolo - *Table lamp*



**CARMEN STEEL**  
Sedia - Chair

**AZIMUT**  
Consolle - Console

**STILO**  
Piantana - Floor lamp



OPERA  
Tavolo da pranzo - Dining table



**UDOLPHO**  
*Bicchiere - Glass*

**CHERON**  
*Set di posate - Set of cutlery*

**UMBERTO**  
*Piatto e segnaposto - Plate and place holder*

**CYBORG HIGH**  
*Tavolino - Low table*

**CARMEN PADDED**  
*Sedia - Chair*









**AZIMUT**  
Madia - Cabinet

**STILO**  
Lampada da tavolo - Table lamp

**FLAMINGOS**  
Art gallery





**AZIMUT**  
Consolle - Console

**ANAEL, URIEL, RAGUEL**  
Scrigno - Chest

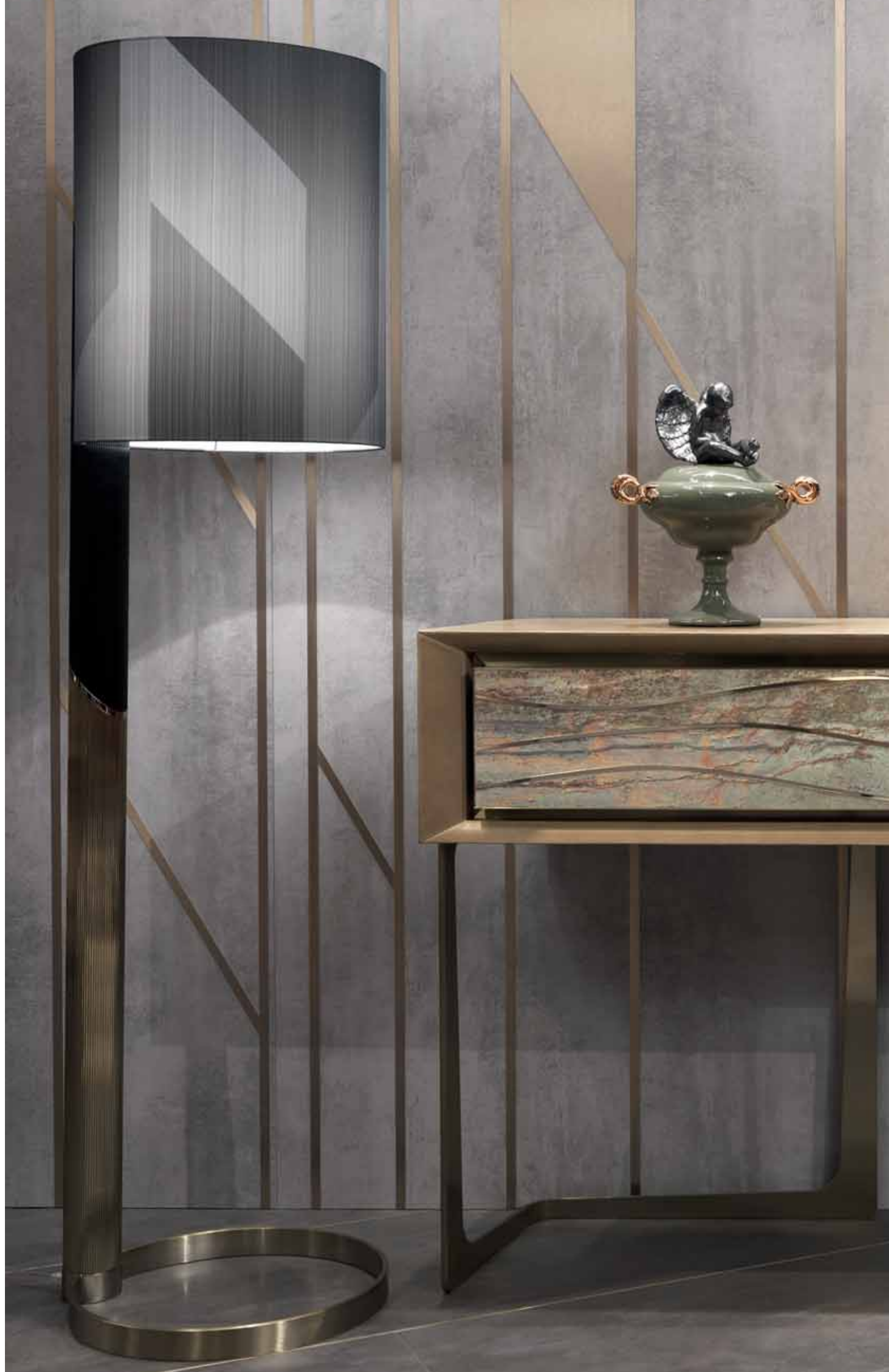





**URIEL**  
Vaso - Vase



**RAGUEL**  
Vaso - Vase



### 01. OPERA

Tavolo da pranzo con Lazy Susan cm Ø180 H.76. Top e base in legno B.181 Fiammato sabbia con profili e inserti in acciaio champagne satinato. Sottotop in alluminio laccato RAL 8019 opaco.

*Dining table cm Ø180 H.76. Top and base in veneer B.181 Fiammato sabbia, steel profiles in satin champagne lacquered steel. Under top in matt laquered metal RAL 8019.*

### 02. CARMEN STEEL

Sedia imbottita cm 68x66 H.79. Rivestimento in Nabuk Maestrale 3415 col. Betulla. Struttura in acciaio champagne satinato.

*Chair cm 68x66 H.79. Chair upholstered in leather Nabuk Maestrale 3415 col. Betulla. Structure in satin champagne steel.*

### 03. CARMEN STEEL

Sedia imbottita cm 68x66 H.79. Rivestimento in pelle Levante 24278/49 Ruggine. Struttura in acciaio champagne satinato.

*Chair cm 68x66 H.79. Chair upholstered in leather Levante 24278/49 Ruggine. Insert in satin champagne steel.*

### 04. CARMEN PADDED

Sedia imbottita cm 65x62 H.81. Rivestimento in pelle Levante 24278/49 Ruggine. Inserto in metallo champagne satinato.

*Chair cm 65x62 H.81. Chair upholstered in leather Levante 24278/49 Ruggine. Insert in satin champagne steel.*

### 05. AZIMUT

Consolle a 2 cassetti cm 180x40 H.95. Struttura rivestita in pelle Cordoba 24279/05 Creta, cassetti con pannello frontale decorativo in pietra. parti metalliche in acciaio champagne satinato. Interni laccati RAL 9005 opaco.

*Console with 2 drawers cm 180x40 H.95. Structure upholstered in leather Cordoba 24279/05 Creta, front of drawers in natural stone. Metal parts in satin champagne metal. Inside matt laquered RAL 9005.*

### 06. AZIMUT

Madia a 4 ante cm 250x50 H.87. Struttura laccata Ral 8019 lucido, ante con pannello frontale decorativo in pietra. Parti metalliche in acciaio champagne satinato. Interni laccati RAL 9005 opaco.

*Cabinet with 4 doors cm 250x50 H.87. Structure in shiny laquered wood Ral 8019, doors in natural stone. Metal parts in satin champagne metal. Inside matt laquered RAL 9005.*

### 07. CYBORG HIGH

Tavolino cm 51x40 H.60. Top in essenza C.902 Sicomoro Frisé. Fianchi in acciaio champagne satinato.

*Low table cm 51x40 H.60. Top in veneer C.902 Sycamore Frisé. Side in satin champagne steel.*

### 08. ETHAN

Lampadario circolare cm Ø110 H.105. Rosone e struttura in acciaio champagne satinato, con tubi in vetro trasparente. Illuminazione perimetrale a LED.

*Circular chandelier cm Ø110 H.105. Structure in satin champagne steel and transparent glasses. LED lighting on perimeter.*

### 09. STILO

Lampada da tavolo cm 34x36 H.70. Base in acciaio champagne satinato e smalto nero lucido, paralume in raso con stampa digitale a motivo geometrico.

*Table lamp cm 34x36 H.70. Pole in champagne and black laquered metal. Lampshade in printed fabric with geometric pattern.*

### 10. STILO

Lampada da terra cm 43x45 H.172. Base in acciaio champagne satinato e smalto nero lucido, paralume in raso con stampa digitale a motivo geometrico.

*Floor lamp cm 43x45 H. 172. Pole in champagne and black laquered metal. Lampshade in printed fabric with geometric pattern.*

### 11. BELAR

Tappeto cm 400x300.

*Carpet cm 400x300.*

### ART GALLERY

Flamingos cm 190x140. Cornice in acciaio champagne.

*Flamingos cm 190x140. Frame in polished champagne steel.*

### CHERON

Set di posate in acciaio nero.

*Set of cutlery in black steel.*

### UMBERTO

Piatto cm Ø31. Vetro marmorizzato grigio con applicazione charms.

*Plate cm Ø31. In gray marmored glass with charms application.*

### UMBERTO

Piatto cm Ø17,5. Vetro marmorizzato grigio con applicazione charms.

*Plate cm Ø17,5. In gray marmored glass with charms application.*

### UMBERTO

Segnaposto con applicazione charms.

*Place holder with charms application.*

### UDOLPHO

Bicchieri cm Ø9,2 H.9,7.

*Glass cm Ø9,2 H.9,7.*

### ANAEL

Scrigno cm Ø31 H.36.

*Chest cm Ø31 H.36.*

### RAGUEL

Scrigno cm Ø35 H.37.

*Chest cm Ø35 H.37.*

### URIEL

Scrigno cm Ø27 H.34.

*Chest cm Ø27 H.34.*

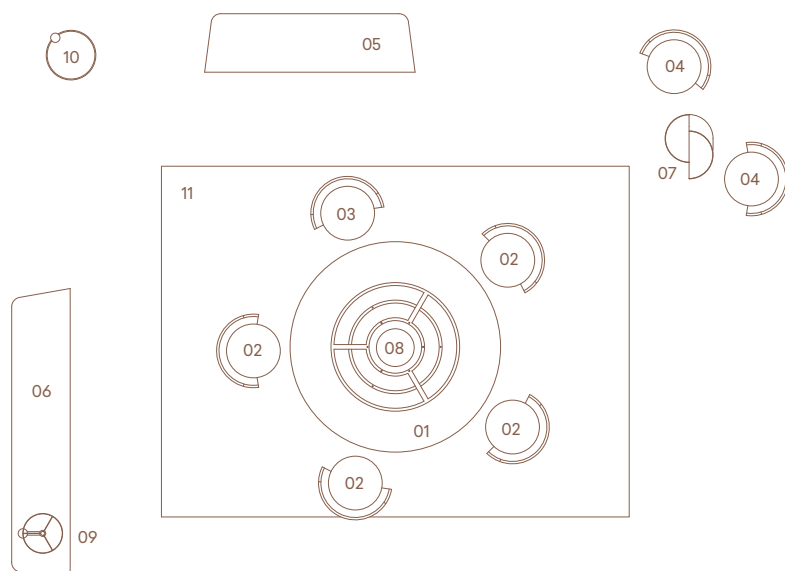

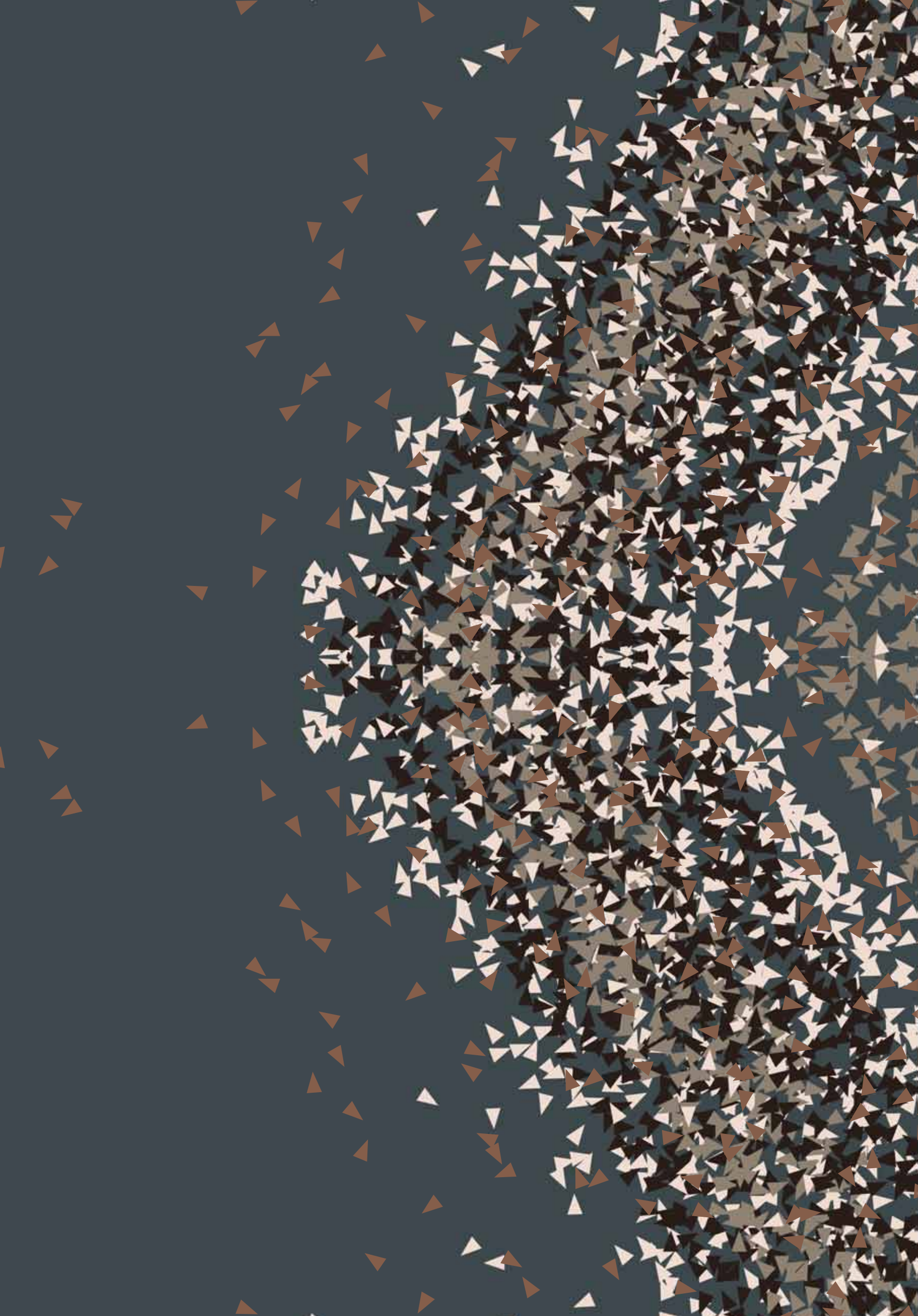



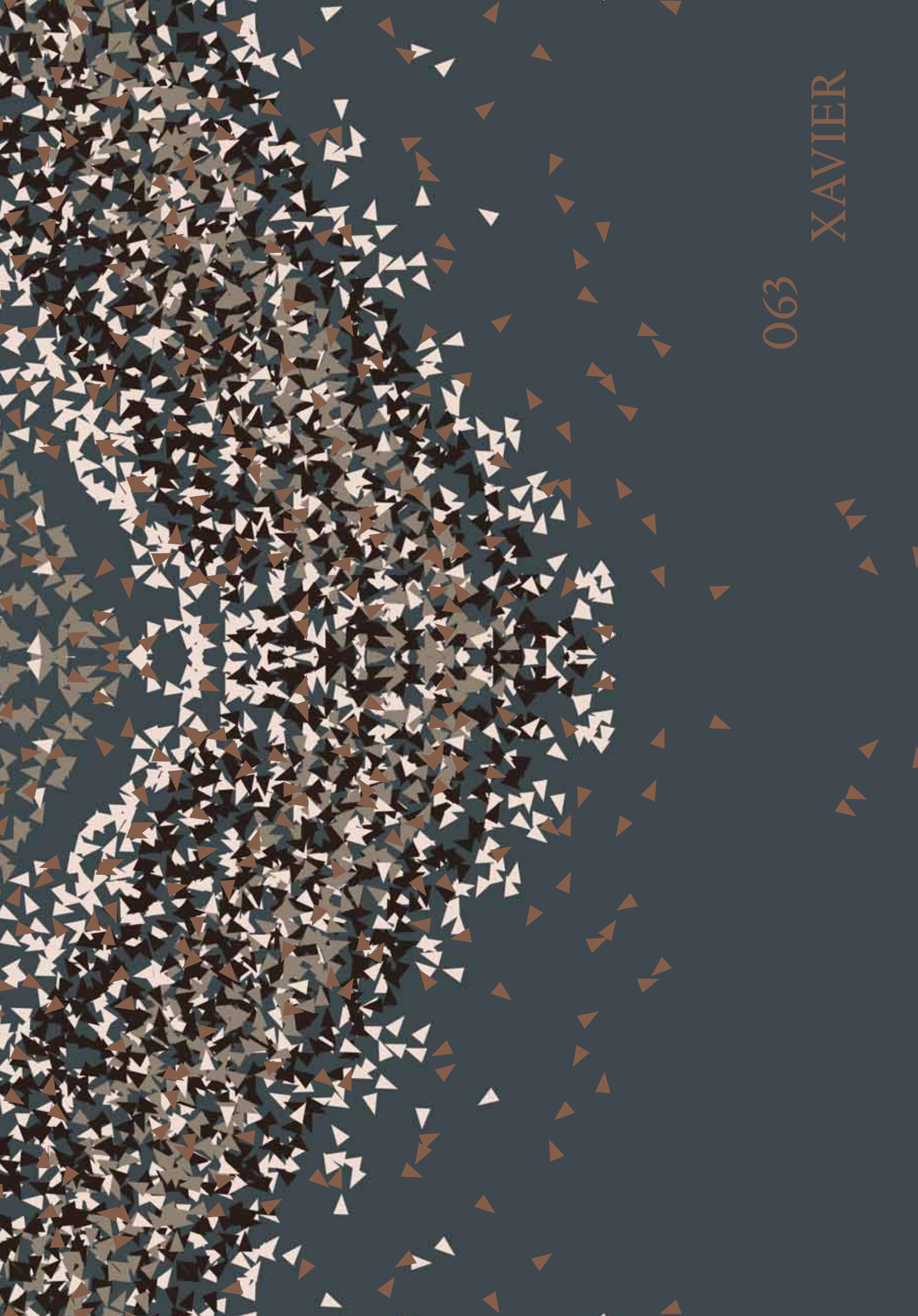

063

XAVIER





**XAVIER MASTER**  
Divano - *Sofa*

**XAVIER MASTER & BOARD  
SECTIONAL**  
Divano componibile - *Modular sofa*

**BOREAL 9**  
Plafoniera rettangolare -  
*Rectangular ceiling lamp*

**RYLAN**  
Tavolo basso - *Low table*

**DANNY**  
Mobile con ante - *Cabinet*

**DANAUS**  
Art gallery

**MINSTREL**  
Tavolo basso - *Low table*

**MARVEL**  
Tappeto - *Carpet*



**XAVIER MASTER & BOARD SECTIONAL**  
Divano componibile - Modular sofa

**MEZZARO GLAM**  
Glam plaid

















**XAVIER BOARD SECTIONAL**  
Divano componibile - Modular sofa





**RYLAN**  
Tavolo basso - *Low table*

**DANNY**  
Mobile con ante - *Cabinet*

**DANAUS**  
Art gallery

**KYNES**  
Lampada da tavolo - *Table lamp*

**XAVIER MASTER &  
BOARD SECTIONAL**  
Divano componibile - *Modular sofa*



**XAVIER MASTER & BOARD SECTIONAL**  
Divano componibile - *Modular sofa*

**MEZZARO GLAM**  
Glam plaid



visionnaire

visionnaire









**XAVIER MASTER**  
Divano - *Sofa*

**RYLAN**  
Tavolo basso - *Low table*



**MINSTREL**  
Tavolo basso - *Low table*

**MARVEL**  
Tappeto - *Carpet*





**BOREAL 9**  
Plafoniera - Ceiling lamp



**KYNES**  
Lampada da tavolo - *Table lamp*

**DANNY**  
Mobile con ante - *Cabinet*

**DANAUS**  
Art gallery





**DANNY**  
Consolle - Console







### 01. XAVIER MASTER

Divano cm 305x110 H.74. Rivestimento scocca in velluto Essential 24154/27 Talpa.

*Sofa cm 305x110 H.74. Upholstery in velvet Essential 24154/27 Talpa.*

### 02. XAVIER MASTER SECTIONAL

Elemento laterale destro cm 160x110 H.74 (XMSR33). Rivestimento in Nabuk Maestrale 24127/3405 Tartufo.

*Right half-sofa cm 168x110 H.74 (XMSR33). Upholstery in leather Nabuk Maestrale 24127/3405 Tartufo.*

### 03. XAVIER BOARD SECTIONAL CON/WITH EXTENSION

Elemento laterale sinistro cm 199x116 H.54 (XBDEXL18). Rivestimento principale in Nabuk Maestrale 24127/3405 Tartufo, bracciolo/ mensola in pelle intreccio Mandala 24281/90 Taupe. Profili metallici in ottone canna di fucile satinato.

Cuscino volante a saponetta cm 45x45. Rivestimento in tessuto Lavino 24266/14 Petrolio. Cuscino volante con fascetta cm 53x53. Rivestimento in tessuto Ocean 24289/587 Ceruleo.

Cuscino volante a saponetta con filetti cm 48x48. Rivestimento in Nabuk Maestrale 24127/3405 Tartufo.

Cuscino volante a saponetta cm 30x30. Rivestimento in pelle intreccio Mandala 24281/90 Taupe e filetti Nabuk Maestrale 24127/3405 Tartufo.

Cuscino volante con fascetta cm 40x40. Rivestimento in Ocean 24289/587 Ceruleo.

*Left half-sofa cm 199x116 H.54 with armrest/shelf (XBDEXL18). Main upholstery in leather Nabuk Maestrale 24127/3405 Tartufo, armrest/shelf in leather intreccio Mandala 24281/90 Taupe. Profiles and plaquets in satinized gunmetal finishing.*

*Loose cushion cm 45x45. Upholstery in fabric Lavino 24266/14 Petrolio.*

*Loose cushion with band cm 53x53. Upholstery in fabric Ocean 24289/587 Ceruleo.*

*Loose cushion with pipings, cm 48x48.*

*Upholstery in Nabuk Maestrale 24127/3405 Tartufo.*

*Loose cushion with pipings, cm 30x30.*

*Upholstery in interwoven leather Mandala 24281/90 Taupe and pipings in Nabuk Maestrale 24127/3405 Tartufo.*

*Loose cushions with band, cm 40x40.*

*Upholstery in fabric Ocean 24289/587 Ceruleo.*

### MEZZARO GLAM

Glam plaid, cm 155x168, blu scuro.

*Glam plaid, cm 155x168, Dark blue.*

### 04. RYLAN

Tavolo basso girevole cm 130/173x90 H.35. Basamento in acciaio canna di fucile satinato, top in legno laccato Ral 5008 lucido.

*Oval low table with rotating top cm 130/173x90 H.35. Base in satin gunmetal steel, top in shiny laquered wood RAL 5008.*

### 05. DANNY

Mobile a 4 ante cm 260x60 H.73. Top e ante in essenza B.558 Erable lucido. Esterno scocca e interno mobile laccato col. Marron Glacè lucido. Interno scocca in acciaio lacca canna di fucile satinato.

*Low unit with four doors cm 260x60 H.73. Top and doors in glossy veneered wood B.558 Erable. External part of the structure and inside in polished Marron Glacè color. Satinized gunmetal steel inside structure.*

### 06. DANNY

Consolle a 3 cassetti cm 180x45 H.88. Top in essenza B.558 Erable lucido. Frontali cassetti rivestiti intreccio pelle Mandala 24281/90 Taupe. Esterno scocche e interni laccati col. Marron Glacè lucido. Interno scocche in acciaio lacca canna di fucile satinato.

*Console with 3 drawers cm 180x45 H. 88. Top in glossy veneered wood B.558 Erable. Front drawers in interwoven Mandala leather 24281/90 Taupe, outside structure and interiors in polished Marron Glacè lacquered wood. Inside structure in satinized gunmetal finishing steel.*

### 07. MINSTREL

Tavolo basso cm 42x39 H.53. Corpo centrale in legno laccato col. mattone NCS S 4050-Y70R lucido. Base in acciaio canna di fucile satinato.

*Low table cm 42x39 H.53. Body in polished NCS S 4050-Y70R lacquered wood. Base in satinized gunmetal steel.*

### 08. BOREAL 9

Plafoniera rettangolare cm 190x45 H. max 250. Plafoniera in acciaio canna di fucile satinato, elementi a sospensione in vetro con finiture titanio sfumato, ottone antico, rame brunito.

*Rectangular ceiling lamp cm 190x45 H. max 250. Ceiling plate in satin gunmetal steel, suspensions in glass with smoked titanium, antique brass and burnished copper finishings.*

### 09. KYNES

Lampada da tavolo cm Ø38 H.68. Basamento in marmo Sahara Noir con paralume in scaglie di alluminio champagne. Componenti in metallo canna di fucile satinato.

*Table lamp cm Ø38 H.68. Base in Sahara Noir marble with lampshade in champagne aluminium plaquets. Metal parts in satinized gunmetal steel.*

### 10. MARVEL

Tappeto cm 400x300 con placche in ottone.

*Carpet cm 400x300 with metal plate.*

### ART GALLERY

Danaus cm 160x130. Cornice in acciaio champagne lucido.

*Danaus cm 160x130. Frame in polished champagne finishing.*

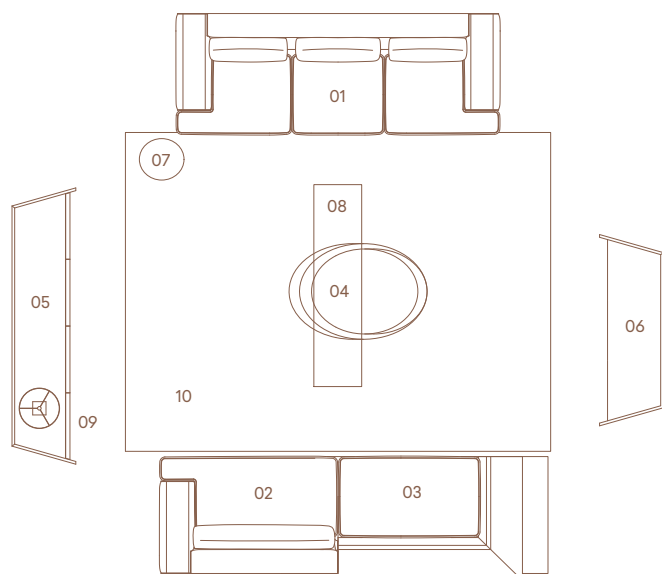

















**KERWAN**  
Tavolo da pranzo - *Dining table*

**ASTRID**  
Sedia - *Chair*

**THAMOS**  
Mobile con ante - *Cabinet*



**HYPERION**  
Tappeto - *Carpet*

**AKIRA**  
Lampada da tavolo - *Table lamp*



**CHERON**  
Set di posate - *Cutlery set*

**UMBERTO**  
Piatto - *Plate*

**UDOLPHO**  
Bicchiere - *Glass*



**ASTRID**  
Sedia - Chair



**ASTRID**  
Sedia - Chair

**HYPERION**  
Tappeto - Carpet





**EKOS**  
Panca - Bench

**KERWAN**  
Tavolo da pranzo - Dining table









**KERWAN**  
Tavolo da pranzo - *Dining table*

**ASTRID**  
Sedia - *Chair*

**THAMOS**  
Mobile con ante - *Cabinet*





**AKIRA**  
Lampadario - *Chandelier*

**EKOS**  
Consolle - *Console*

**AKIRA**  
Applique - *Wall lamp*

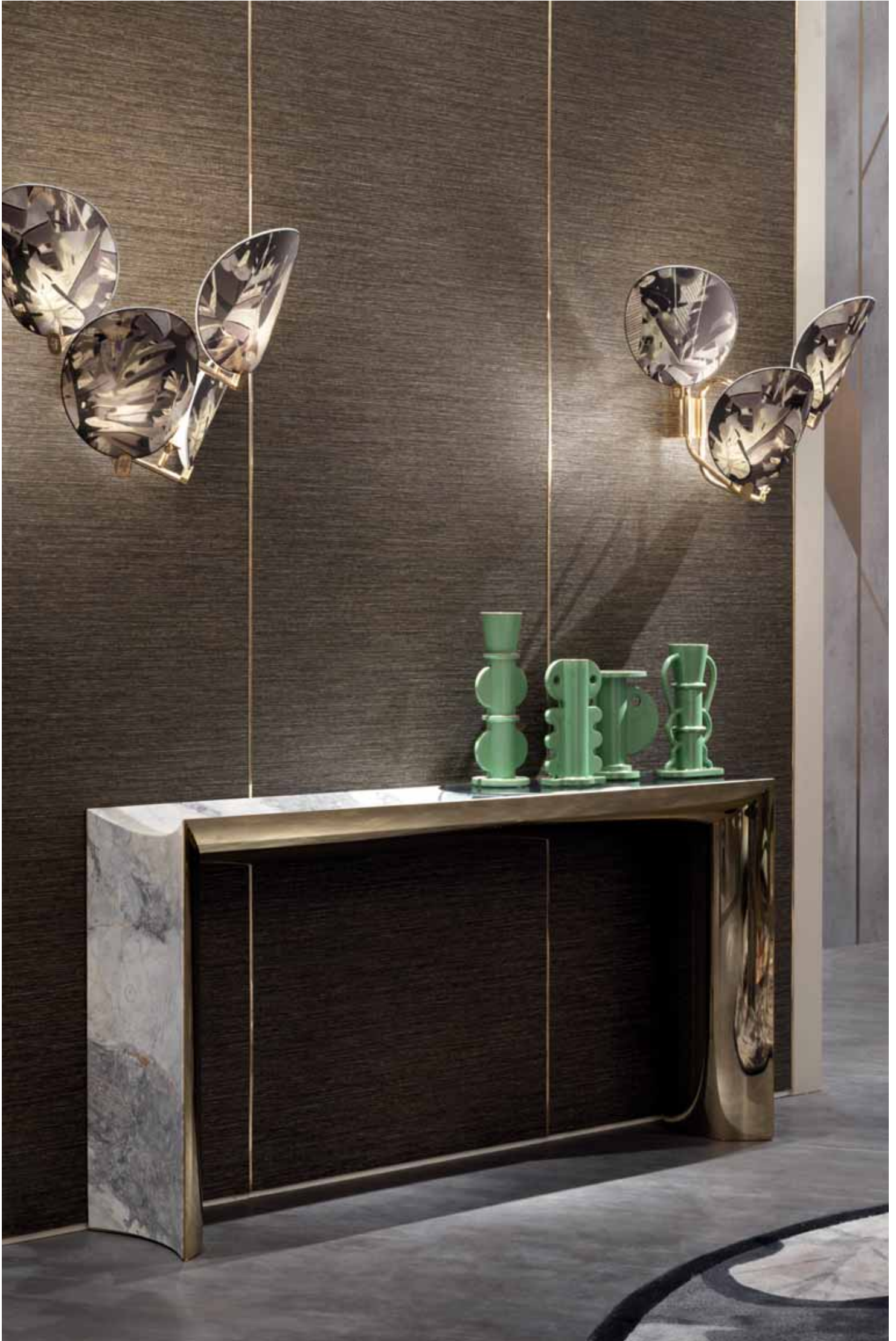





AKIRA  
Applique - Wall lamp





EKOS  
Consolle - Console



**AKIRA**  
Applique - Wall lamp

**CATTEDRALE N41**  
**CATTEDRALE N42**  
Art gallery





**EKOS**  
Consolle - *Console*

**TINNE/L**  
Sassi in ceramica - *Ceramic stone*





**THAMOS**  
Mobile con ante - *Cabinet*

**AKIRA**  
Lampada da tavolo - *Table lamp*

**REVEL**  
Vaso porta candela - *Candle-holder vase*





**THAMOS**  
Mobile con ante - Cabinet

**TINNE/L**  
Sassi in ceramica - Ceramic stone

**TINNE/P**  
Sassi in ceramica - Ceramic stone







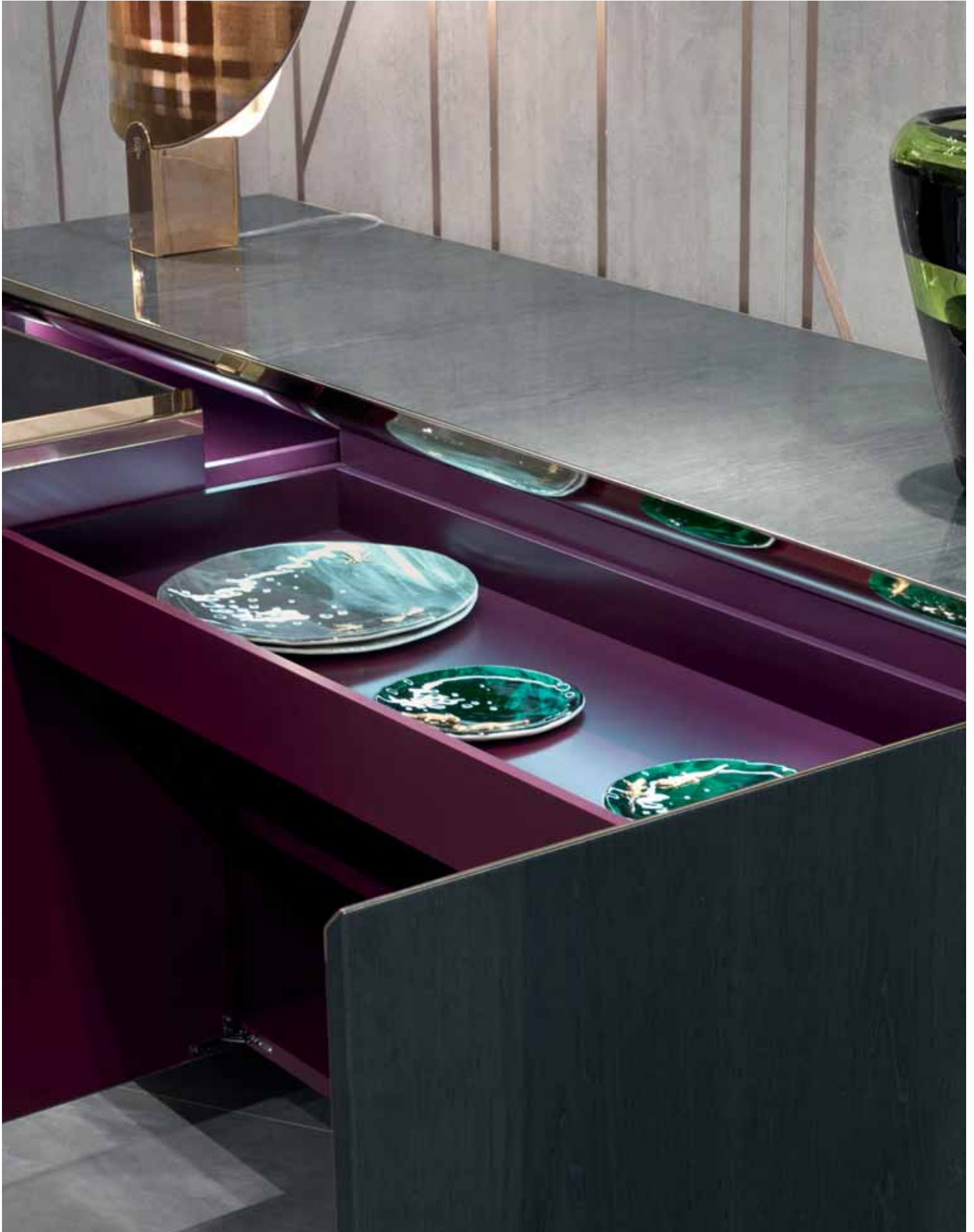

**THAMOS**  
Mobile con ante - Cabinet

**UMBERTO**  
Piatto - Plate



### 01. KERWAN

Tavolo da pranzo cm 270x110 H.75. Top in marmo Invisible Grey e sottotop legno laccato Ral 7022 grigio. Basamento in acciaio inox curvato oro lucido con superfici esterne concave in marmo Invisible Grey curvato e lucidato.

*Dining table cm 270x110 H.75. Top in Invisible Grey marble and undertop in Ral 7022 lacquered wood. Base in curved shiny gold stainless steel with external panels in curved and polished Invisible Grey marble.*

### 02. ASTRID

Sedia imbottita cm 52x63 H.95. Rivestimento interno e filetti in pelle Malta 24261/11 Larice. Retro schienale in pelle Malta 24261/11 Larice con trapuntatura disegno foliage. Gambe in fusione di alluminio oro satinato.

*Padded chair cm 52x63 H.95. Internal upholstery and pipings in leather Malta 24261/11 Larice. Back in leather Malta 24261/11 Larice with foliage quilted pattern. Legs in brushed gold aluminium cast.*

### 03. EKOS

Panca imbottita cm 150x42 H.50. Seduta in pelle Malta 24261/11 Larice con trapuntatura disegno foliage. Base in acciaio oro lucido con elementi laterali in marmo concavo Invisible Grey.

*Bench cm 150x42 H.50. Linear seat with upholstery and pipings in leather Malta 24261/11 Larice with foliage quilted pattern. Steel structure in polished golden lacquer finishing with concave-shaped side elements in Invisible Grey marble.*

### 04. EKOS

Consolle cm 180x35 H.90. Top e fianchi concavi in essenza C.001 Frassino lucido. Parte interna in acciaio curvato oro lucido. Top superiore in cristallo fumè.

*Console cm 180x35 H.90. Wooden concave legs and top in glossy veneer C.001 ash. Inside part in curved polished gold steel. Second smoked crystal top.*

### 05. EKOS

Consolle cm 180x35 H.90. Top e fianchi concavi in marmo Invisible Grey lucido. Parte interna in acciaio curvato oro lucido. Top superiore in cristallo fumè.

*Console cm 180x35 H.90. Concave legs and top in Invisible Grey polished marble. Inside part in curved polished gold steel. Second smoked crystal top.*

### 06. THAMOS

Madia alta a 4 ante e 3 cassetti cm 250x50 H.94. Fianchi concavi e top in essenza C.001 Frassino lucido. Cornice in acciaio curvo oro lucido. Interno, ripiani e cassetti laccati RAL 3007 opaco. Illuminazione interna a led.

*High unit with 4 doors and 3 drawers cm 250x50 H.94. Concave legs and top in glossy veneer C.001 ash. Curved frame in polished gold steel. Interiors laquered in RAL 3007 matt. Courtesy led light.*

### 07. AKIRA

Applique a 2 bracci cm 60x55 H.60. Struttura in ottone oro lucido. Paralumi in seta a stampa floreale e interno in tessuto moirè.

*Wall lamp cm 60x55 H.60. Structure in polished golden brass. Fan-shaped lampshades in silk with floral print and inside in moiré fabric.*

### 08. AKIRA

Lampadario a 16 luci Ø130 H.90 cm. Struttura in ottone oro lucido. Paralumi in seta motivo floreale e interno in tessuto moirè.

*Chandelier with 16 lights Ø130 H.90 cm. Structure in polished golden brass. Fan-shaped lampshades in silk with floral print and inside in moiré fabric.*

### 09. AKIRA

Lampada da tavolo cm 42x11 H.62. Base in ottone oro lucido. Paralume in tessuto Oban 24287/02 Muschio e interno in tessuto moirè.

*Table lamp cm 42x11 H.62. Base in polished golden brass. Fan-shaped lampshades in fabric Oban 24287/02 Muschio and inside in moiré fabric.*

### 10. HYPERION

Tappeto ovale cm 400x300 con logo in ottone.

*Oval carpet cm 400x300 with brass plate.*

### ART GALLERY

Cattedrale N41 cm 130x80 cm  
Cattedrale N42 cm 130x80 cm

### CHERON

Set di posate in acciaio nero.

*Set of cutlery in black steel.*

### UMBERTO

Piatto Ø 31 cm. Vetro marmorizzato verde con applicazione charms.

*Plate cm Ø31. In green marmored glass with charms application.*

### UMBERTO

Piatto Ø 17,5 cm. Vetro marmorizzato verde con applicazione charms.

*Plate cm Ø17,5. In green marmored glass with charms application.*

### UDOLPHO

Bicchiere cm Ø9,2 H.9,7.

*Glass cm Ø9,2 H.9,7.*

### REVEL

Vaso porta candela cm Ø19 H.24.

*Candle-holder vase cm Ø19 H.24.*

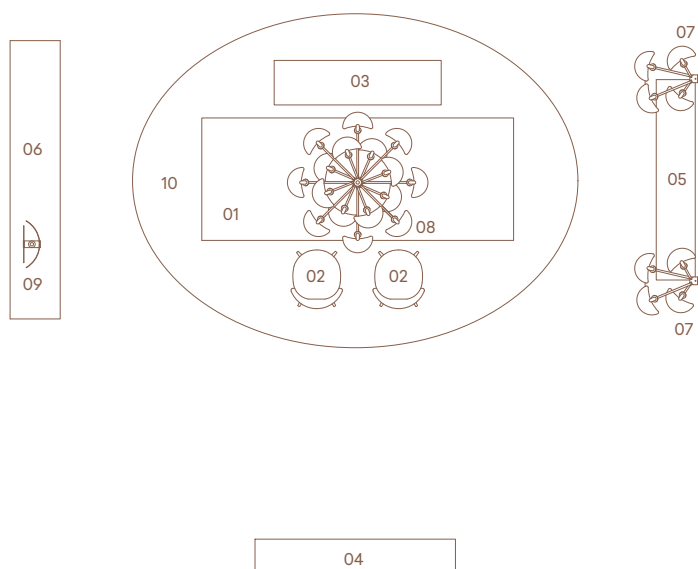

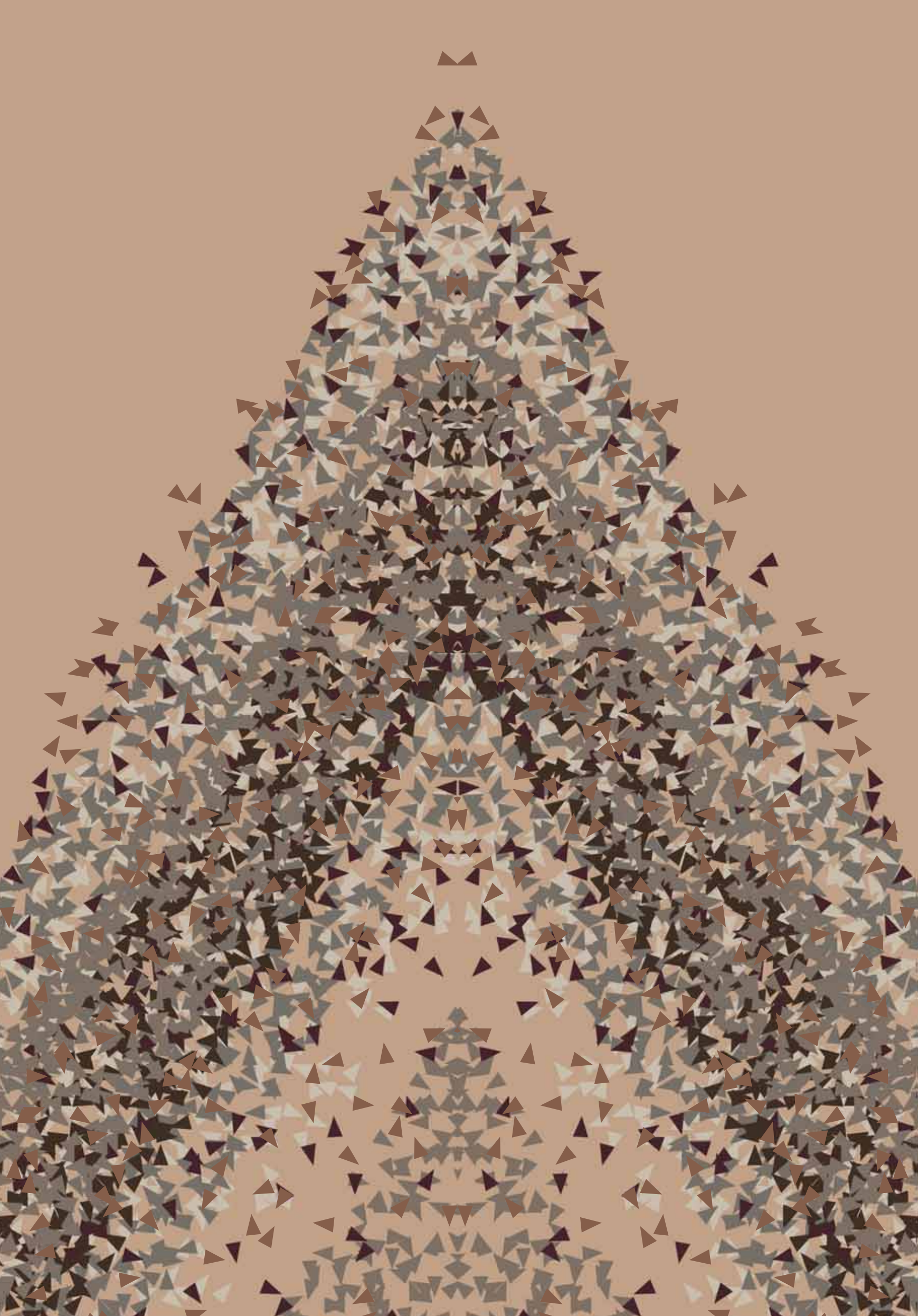

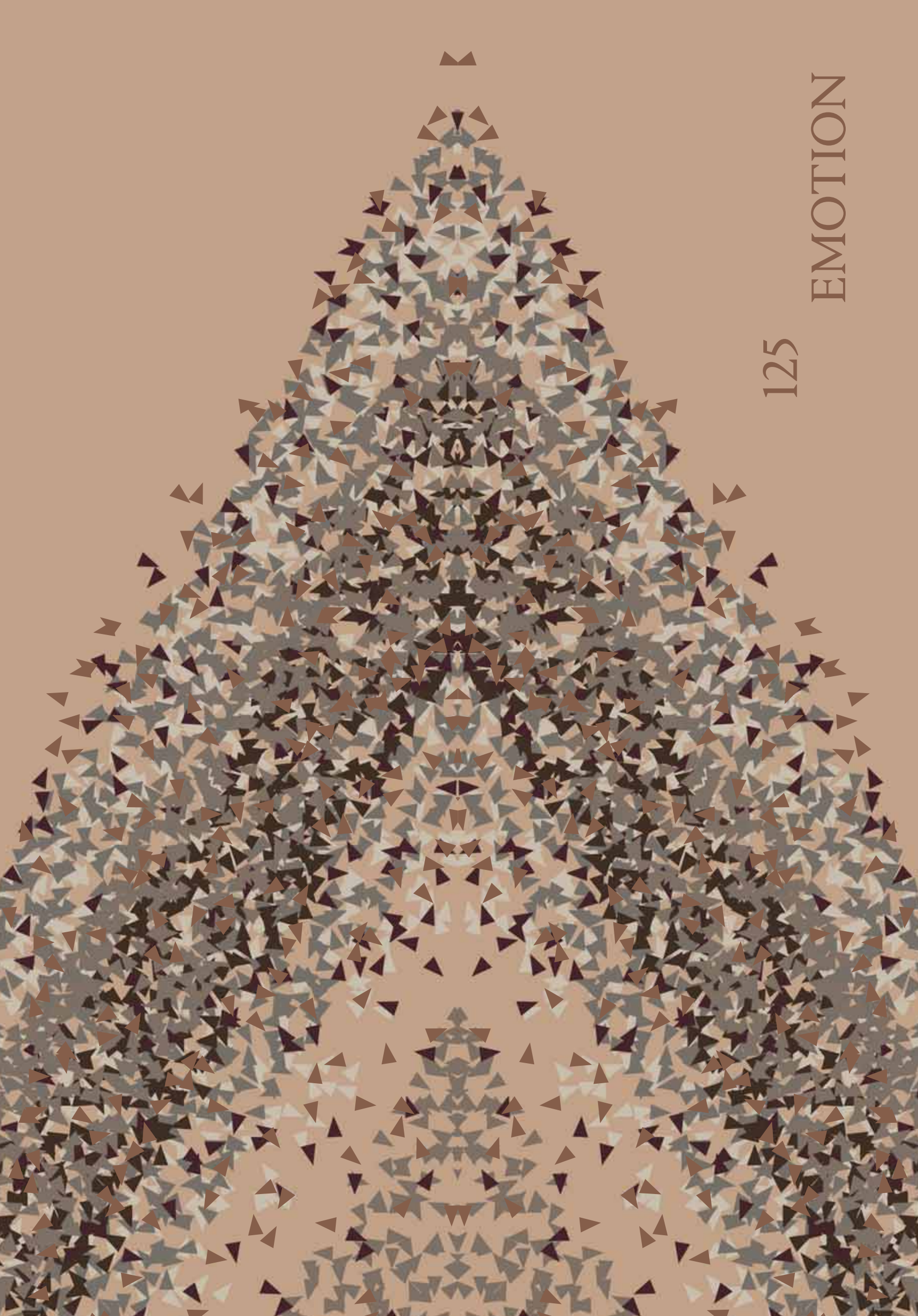

125

EMOTION













EMOTION  
Letto - Bed



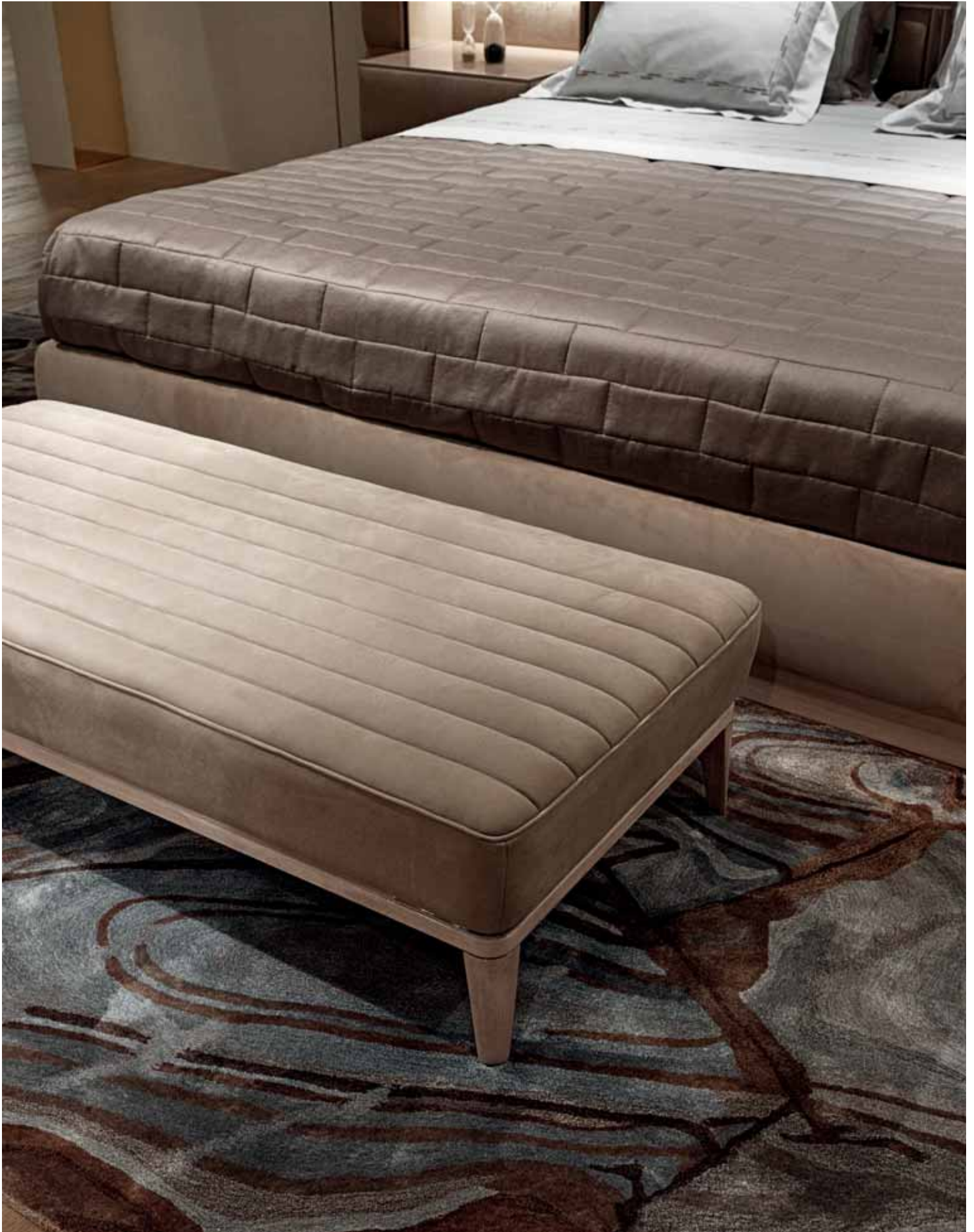

**BLONDIE**  
Panca - Bench

**SECRET**  
Set lenzuola - Set of sheets

**MARVEL**  
Tappeto - Carpet









**RAWDON**  
Mobile trucco - *Make-up cabinet*

**ANASTASIA**  
Sedia - *Chair*

**BIRCHES**  
Art gallery



**ANASTASIA**  
Sedia - Chair

**RAWDON**  
Mobile trucco - Make-up cabinet



**RAWDON**

Cassettiera - *Chest of drawers*

**ASTRA**

Lampada da tavolo - *Table lamp*









**BLONDIE**  
Poltroncina - *Armchair*

**RAWDON**  
Cassettiera - *Chest of drawers*



**EMOTION**  
Letto - Bed

**BRANDO**  
Lampadario - Chandelier

**RAWDON**  
Cassettiera - Chest of drawers

**BLONDIE**  
Poltrona - Armchair





**BLONDIE**  
Panca - Bench

**CYBORG LARGE**  
Tavolino - Low table

**HARMONY**  
Mobile portalavabo - Console with basin

**MADDY**  
Lampada a sospensione - Suspension lamp







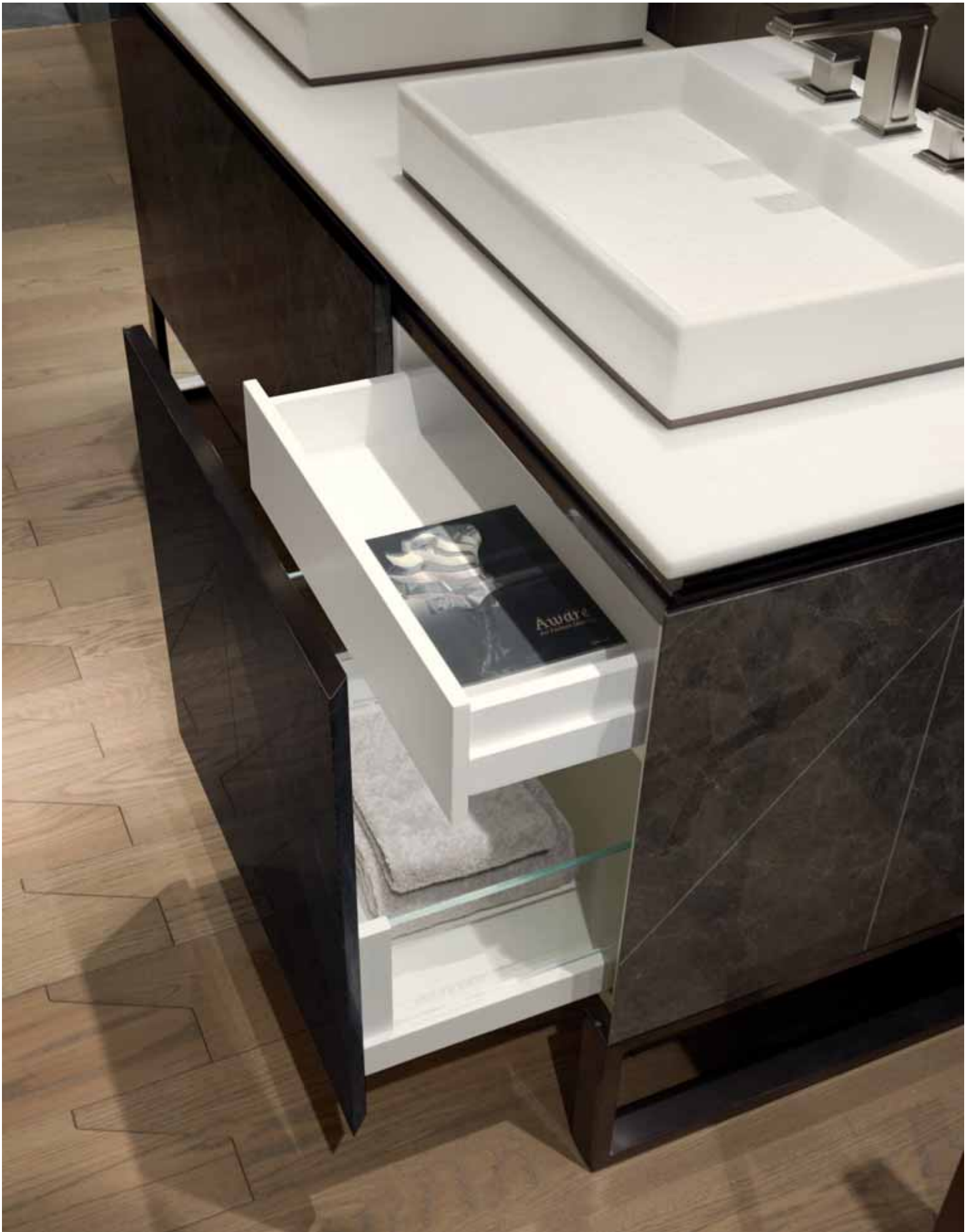

**HARMONY**  
Mobile portlavabo - Console with basin

**HARMONY**  
Specchiera - Mirror

**HARMONY**  
Appendiabiti - Clothes hanger

**MADDY**  
Lampade a sospensione - Suspension lamp





**HARMONY**  
Portasciugamani - Towel holder

**SECRET**  
Set di asciugamani - Set of bath towels





## 01. EMOTION

Letto con testata attrezzata cm 363x237 H.47/140. Struttura in legno C.507 Eucalipto Frisè, rivestimento in pelle Nabuk Maestrale 24127/3415 Betulla, inserti in acciaio canna di fucile satinato, interno cassetti laccato RAL 9010 opaco.

*Bed with equipped headboard cm 363x237 H.47/140. Structure in veneered wood C.507 Eucalipto Frisè, upholstered in Nabuk Maestrale 24127/3415 Betulla, inserts in gunmetal satinized steel, internal drawers in mat lacquer RAL 9010.*

## SECRET

Copiletto in lino con trapuntatura cm 270x270

*Bedcover cm 270x270 in linen with quilting*

Set di lenzuola con 2 federe in chambray cm 80x50.

*Set of sheets with 2 pillow cases cm 80x50 in chambray.*

Set di 2 federe in raso supplementari cm 80x50.

*Set of 2 additional pillow cases in satin cm 80x50.*

## 02. BLONDIE

Poltroncina cm 65x80 H.66. Struttura di base in legno C.507 Eucalipto Frisè, profilo in acciaio canna di fucile satinato. Rivestimento interno tessuto Leeds 24292/04 Argilla e filetti in pelle Taras Leather 24296/26 Calce. Rivestimento esterno pelle Taras Leather 24296/26 Calce.

*Armchair cm 65x80 H.66. Base in wood C.507 Eucalipto Frisè, profile in gunmetal satinized steel. Internal upholstery in fabric Leeds 24292/04 Argilla and pipings in leather Taras 24296/26 Calce. External upholstery in leather Taras 24296/26 Calce.*

## 03. BLONDIE

Panca cm 136x62 H.37. Struttura di base in legno C.507 Eucalipto Frisè, profilo in acciaio finitura lacca canna di fucile satinato. Rivestimento e filetti in pelle Taras Leather 24296/26 Calce.

*Bench cm 136x62 H.37. Base in wood C.507 Eucalipto Frisè, profile in gunmetal satinized steel. Upholstery and pipings in Taras Leather 24296/26 Calce.*

## 04. RAWDON

Mobile contenitore a 4 cassetti cm 250x50/43 H.75. Struttura esterna rivestita in pelle Taras Leather 24296/26 Calce. Frontali cassetti placcati essenza legno C.507 Eucalipto Frisè, gole perimetrali in specchio bronzo, profili in acciaio canna di fucile satinato, interno cassetto laccato RAL 3007 opaco. Schienale laccato Ral 1013 opaco.

*Low unit with 4 drawers cm 250x50/43 H.75. External structure upholstered in leather Taras 24296/26 Calce. Drawers front part in veneered wood C.507 Eucalipto Frisè, perimetral frame in bronzed mirror, profiles in gunmetal satinized steel, inside drawers in RAL 3007 mat. Rear-back in RAL 1013 matt finishing.*

## 05. RAWDON

Mobile trucco con specchio cm 170x55 H.75/118. Struttura rivestita in pelle Galuchat 24130/482 Sabbia. Sottomano in legno C.507 Eucalipto Frisè, cornice perimetrale incassata rivestita in specchio bronzo, profili in acciaio canna di fucile satinato, interno cassetto laccato RAL 3007 opaco. Schienale laccato Ral 1013 opaco.

*Make-up desk with mirror cm 170x55 H.75/118. Structure fully covered in leather Galuchat 24130/482 Sabbia. Desk pad in veneered wood C.507 Eucalipto Frisè, built-in perimetral frame in bronzed mirror, profiles in gunmetal satinized steel, internal drawer in RAL 3007 matt. Rear back in Ral 1013 mat.*

## 06. ANASTASIA

Sedia cm 56x56 H.75. Rivestimento integrale in cuoio Kenya 24164/02 Betulla, spessore mm 3.

*Chair cm 56x56 H.75. Entirely upholstered in cuoio leather Kenya 24164/02 Betulla 3 mm thickness.*

## 07. CYBORG LARGE

Tavolino cm 60x68 H.42. Top in essenza C.507 Eucalipto Frisè. Fianchi in acciaio canna di fucile satinato.

*Low table cm 60x68 H.42. Top in veneered wood C.507 Eucalipto Frisè. Sides in gunmetal satinized steel.*

## 08. BRANDO

Lampadario ottagonale cm Ø75 H.79. Struttura in acciaio e ottone canna di fucile satinato. Paralumi in marmo Onice avorio.

*Octagonal chandelier cm Ø75 H.79. Structure in satin gunmetal steel and brass. Lampshades in Ivory Onyx marble.*

## 09. BRANDO

Applique cm 46x20 H.53. Struttura in acciaio e ottone canna di fucile satinato. Paralumi in marmo Onice avorio.

*Wall lamp cm 46x20 H.53. Structure in satin gunmetal steel and brass. Lampshades in Ivory Onyx marble.*

## 10. ASTRA

Lampada da tavolo cm Ø35 H.55. Base e paralume in metallo canna di fucile lucido; stelo e veletta in vetro soffiato finitura trasparente/satinato.

*Table lamp cm Ø35 H.55. Base and lampshade in polished gunmetal steel; stem and vell in transparent/satinized blown glass.*

## 11. MARVEL

Tappeto cm 400x300 con placche in ottone.

*Carpet cm 400x300 with metal plate.*

## 12. HARMONY

Consolle lavabo doppio cm 180x60 H.90. Rivestimento in marmo Jolie Grey scolpito a bassorilievo e inserti in acciaio canna di fucile satinato, top e 2 lavabi cm 60x48 in marmo bianco Vasilia "T". Interni laccati RAL 9010 opaco. Gambe in acciaio canna di fucile satinato.

*Double washbasin console cm 180x60 H.90. Fully covered in Jolie Grey marble with bas-relief work and inserts in satinized gunmetal steel, top and 2 washbasins cm 60x48 in white marble Vasilia "T". Interiors in RAL 9010 matt lacquer. Legs in gunmetal satinized steel.*

## 13. HARMONY

Specchiera cm 44x120. Cornice in acciaio canna di fucile satinato, inserto diagonale in marmo Jolie Grey.

*Mirror cm 44x120. Frame in gunmetal satinized steel and diagonal insert in Jolie Grey marble.*

## 14. HARMONY

Porta asciugamani cm 60x30 H.84. Acciaio canna di fucile satinato, ripiano in marmo Jolie Grey.

*Towel holder cm 60x30 H.84. Satinized gunmetal steel, support in Jolie grey marble.*

## 15. HARMONY

Appendiabiti cm 9x4 H.15. Acciaio canna di fucile satinato, inserto in marmo Jolie Grey.

*Clothes hanger cm 9x4 H.15. Satinized gunmetal steel, insert in Jolie Grey marble.*

## 16. MADDY

Lampade a sospensione cm Ø8 H.23. Marmo Statuario Veneto, ghiera in ottone canna di fucile satinato.

*Suspended lamp cm Ø8 H.23. Statuario Veneto marble, ring in satinized gunmetal brass.*

## SECRET

Set di asciugamani, 100% spugna di cotone con ricamo Krizia con bordo in chambray, cm 40x60, cm 60x110.

*Set of bath towels, 100% cotton terry with Krizia embroidery in chambray, cm 40x60, cm 60x110.*

## ART GALLERY

Birches cm 190x130. Cornice in acciaio lucido.

*Birches cm 190x130. Polished steel frame.*

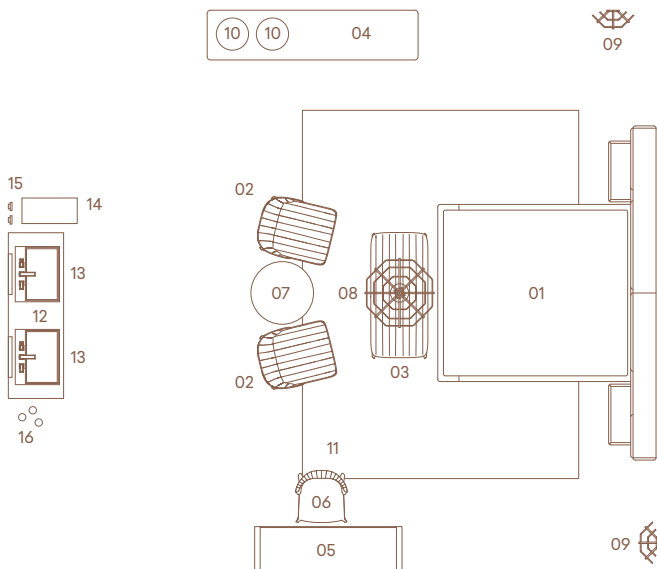

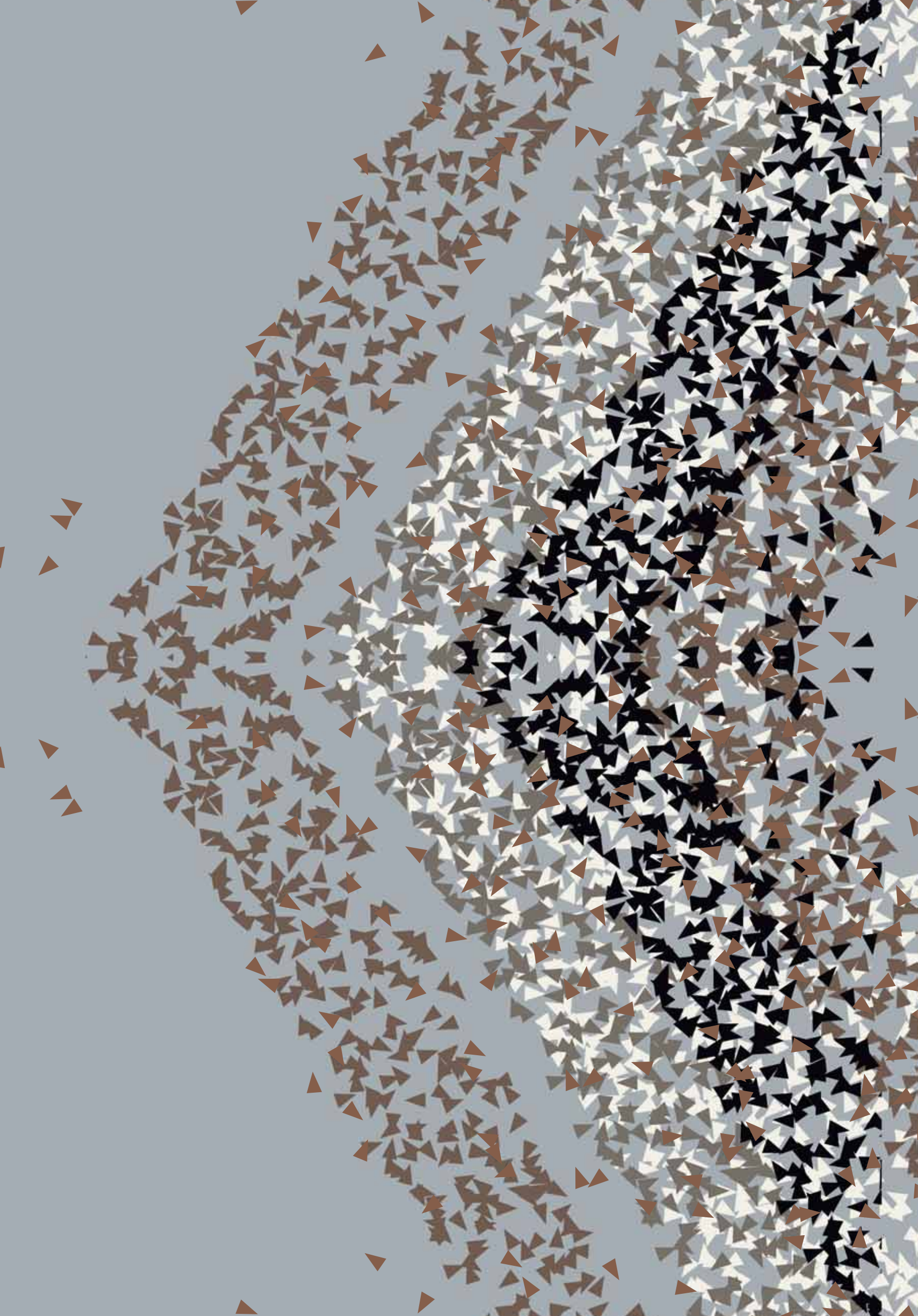

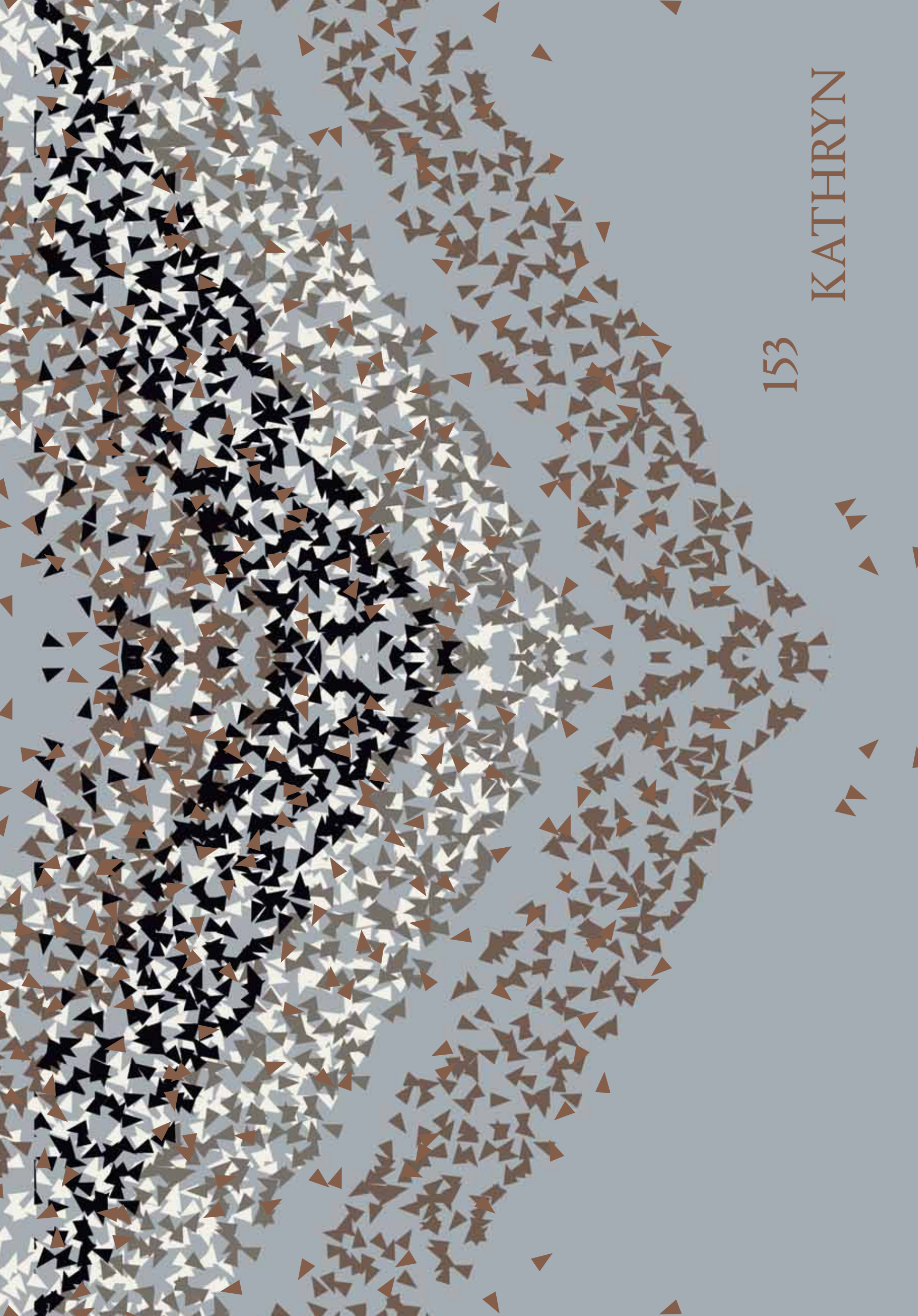

153

KATHRYN







**KATHRYN**  
Poltrona outdoor - *Outdoor armchair*

**KATHRYN**  
Lampada outdoor - *Outdoor lamp*

**OBERTO**  
Tavolo basso - *Low table*

**BREEZE OUTDOOR**  
Tavolo basso - *Low table*



**MEDUSA**  
Plafoniera - *Ceiling lamp*

**POMPEI**  
Tappeto outdoor - *Outdoor carpet*





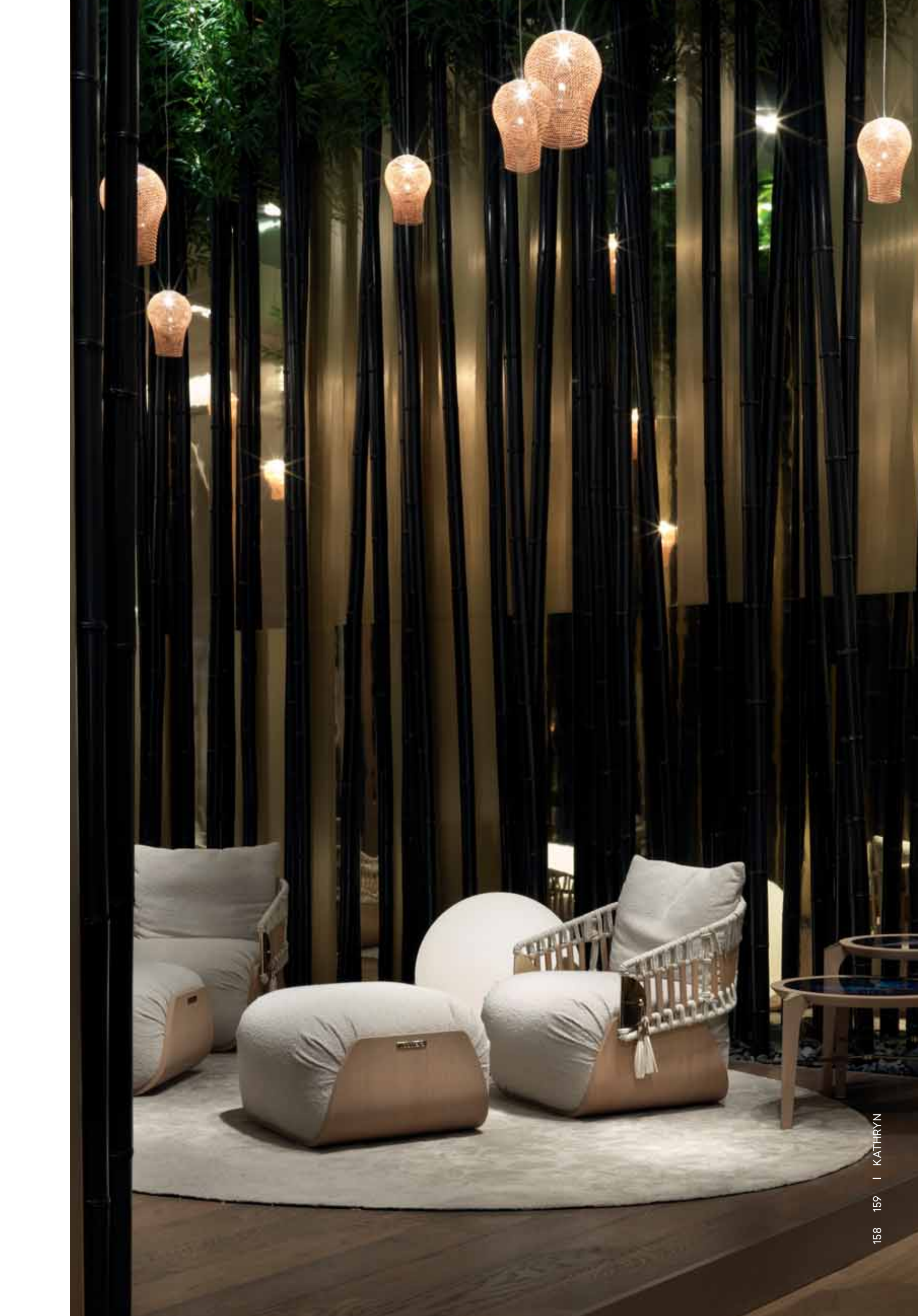



**KATHRYN**  
Poltrona outdoor - *Outdoor armchair*

**KATHRYN**  
Lampada outdoor - *Outdoor lamp*

**KATHRYN**  
Pouf outdoor - *Outdoor pouffe*

**ERCOLANO**  
Tappeto outdoor - *Outdoor carpet*









**OBERTO**  
Tavolo basso - *Low table*

**KRAKEN**  
Posacenere - *Ashtray*

**MORAX**  
Vaso porta candele - *Candle-holder vase*

**MEDUSA**  
Plafoniera - *Ceiling lamp*









**BREEZE OUTDOOR**  
Tavolo basso - *Low table*

**KATHRYN**  
Poltrona outdoor - *Outdoor armchair*

**KATHRYN**  
Pouf outdoor - *Outdoor pouffe*

**ERCOLANO**  
Tappeto outdoor - *Outdoor carpet*

**KATHRYN**  
Lampada outdoor - *Outdoor lamp*



### 01. KATHRYN

Poltroncina outdoor cm 74x73 H.64. Struttura in legno curvato impiallacciato Teak. Schienale ad intreccio in corda di lino grezzo e legno. Particolari metallici oro lucido. Nappa decorativa in Kenya 24164/01 Bianco. Cuscini in tessuto Rapallo 3014/207 Platino.

*Outdoor armchair cm 74x73 H.64. Structure in curved wood, teak veneered. Back with weave in natural linen and wood. Details in shiny gold steel. Decorative tassels in cuoio leather Kenya 24164/01 Bianco. Cushions in fabric Rapallo 3014/207 Platino.*

### 02. KATHRYN

Poltroncina outdoor cm 74x73 H.64. Struttura in legno curvato impiallacciato Teak. Schienale ad intreccio in corda di lino grezzo e legno. Particolari metallici oro lucido. Nappa decorativa in cuoio Kenya 24164/01 Bianco. Cuscini in tessuto Rapallo 3014/108 Cenere.

*Outdoor armchair cm 74x73 H.64. Structure in curved wood, teak veneered. Back with weave in natural linen and wood. Details in shiny gold steel. Decorative tassels in cuoio leather Kenya 24164/01 Bianco. Cushions in fabric Rapallo 3014/108 Cenere.*

### 03. KATHRYN

Pouf outdoor cm 70x58 H.41. Struttura in legno curvato impiallacciato Teak. Particolari in ottone oro lucido. Rivestimento in tessuto Rapallo 3014/108 Cenere.

*Outdoor pouffe cm 70x58 H.41. Structure in curved wood, teak veneered. Details in shiny gold brass. Upholstery in fabric Rapallo 3014/108 Cenere.*

### 04. KATHRYN

Lampada outdoor con diffusore sferico cm 60x64 H.62. Struttura in legno curvato impiallacciato Teak. Particolari in ottone oro lucido. Nappa decorativa in cuoio Kenya 24164/01 Bianco.

*Outdoor lamp with spherical diffuser cm 60x64 H.62. Structure in curved wood, teak veneered. Details in shiny gold brass. Decorative tassels in cuoio leather Kenya 24164/01 Bianco.*

### 05. MEDUSA

Lampadario singolo cm Ø18. Diffusore sferico in vetro decorato con drappo di maglia in bronzo.

*Ceiling light, single element cm Ø18. Spherical diffuser in glass with bronze chain mail.*

### 06. POMPEI

Tappeto outdoor ellittico cm 350x250.

*Outdoor oval carpet cm 350x250.*

### 07. ERCOLANO

Tappeto outdoor ellittico cm 350x250.

*Outdoor oval carpet cm 350x250.*

### 08. BREEZE OUTDOOR

Tavolo basso cm Ø60 H.41. Top in vetro con soggetto "Farfalla Blu". Struttura in legno iroko naturale. Particolari in ottone oro satinato.

*Low table cm Ø60 H.41. Top in glass with blue butterfly. Structure in natural Iroko wood. Details in gold satinized brass.*

### 09. BREEZE OUTDOOR

Tavolo basso cm Ø50 H.51. Top in vetro con soggetto "Colibrì". Struttura in legno iroko naturale. Particolari in ottone oro satinato.

*Low table cm Ø50 H.51. Top with humming bird. Structure in natural Iroko wood. Details in gold satinized brass.*

### 10. BREEZE OUTDOOR

Tavolo basso cm Ø40 H.61. Top in vetro con soggetto "Pesci Lottatori". Struttura in legno iroko naturale. Particolari in ottone oro satinato.

*Low table cm Ø40 H.61. Top with Betta Splendes fish. Structure in natural Iroko wood. Details in gold satinized brass.*

### 11. OBERTO

Tavolo basso cm Ø126 H.42. Struttura in manao scortecciato laccato nero. Top in marmo Striato Olimpico.

*Low table cm Ø126 H.42. Main structure in black lacquered manao. Top in Striato Olimpico marble.*

### MORAX

Vaso porta candela cm Ø19 H.32.

*Candle holder vase cm Ø19 H.32.*

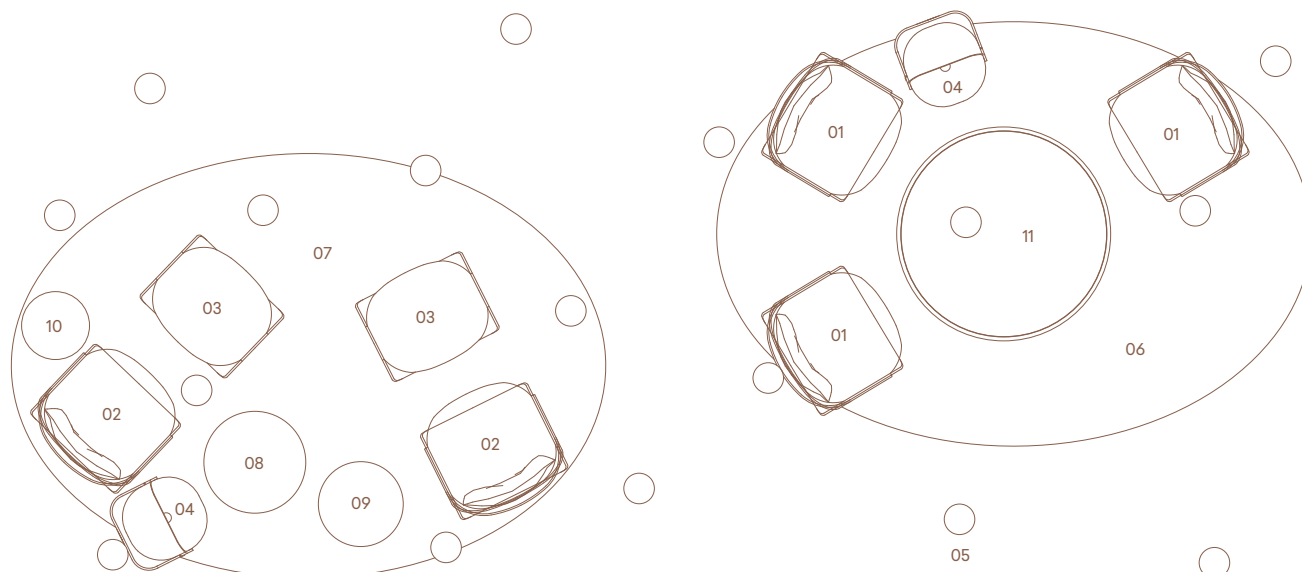

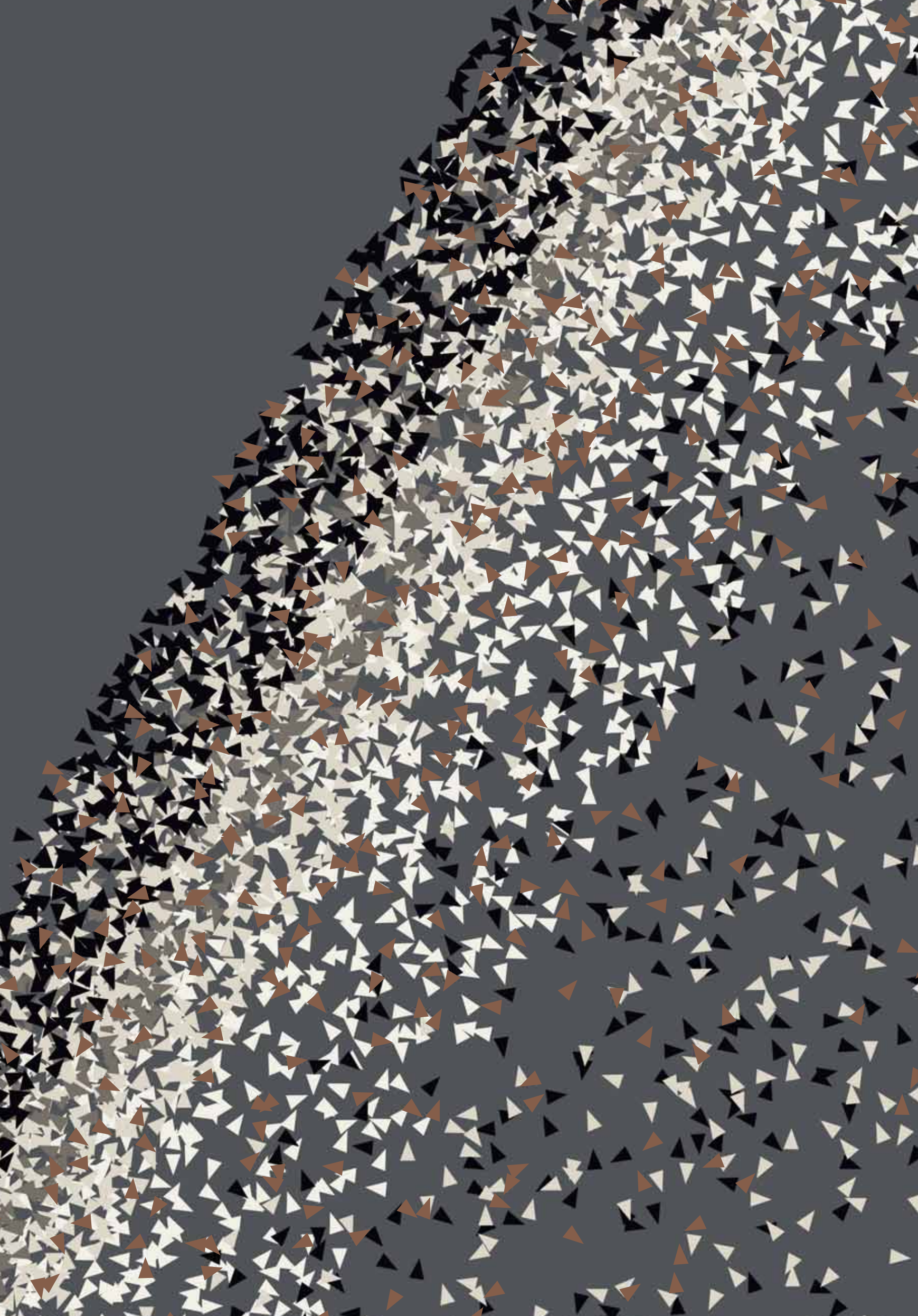

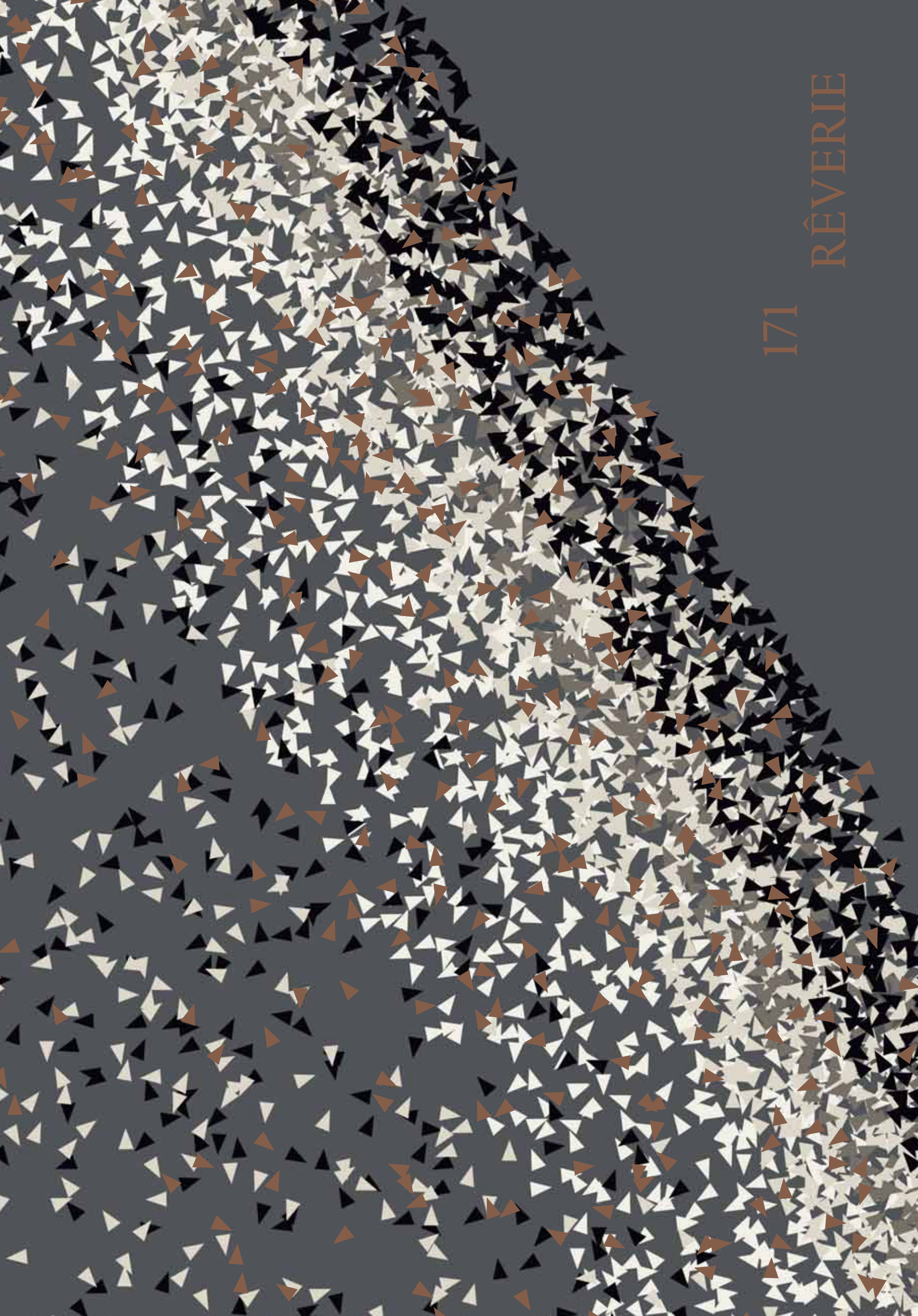



**RÊVERIE**  
Letto - Bed

**NOMOS SHAPED**  
Comodino - Bedside table

**RUPERT**  
Tavolo basso - Low table



**ANTHAR**  
Dormeuse - Left dormeuse

**TANYA**  
Poltroncina - Armchair

**REGIS**  
Tappeto - Carpet















**RÊVERIE**  
Letto - *Bed*

**NOMOS SHAPED**  
Comodino - *Bedside table*

**MADDY**  
Lampada a sospensione - *Suspension lamp*

**MILO**  
Specchio - *Mirror*



**CHAMBRE CINQ**  
Set di lenzuola - Set of sheets









**RÊVERIE**  
Letto - *Bed*

**NOMOS SHAPED**  
Comodino - *Bedside table*





**ANTHAR**  
Dormeuse - *Dormeuse*

**FLOYD**  
Piantana - *Floor lamp*



**NOMOS SHAPED**  
Cassettiera - Chest of drawers

**EUCLIDE**  
Lampada da tavolo - Table lamp

**ARBOR**  
Art gallery

**TRACCIA 11**  
Art gallery







**TANYA**  
Poltroncina - *Armchair*

**RUPERT**  
Tavolo basso - *Low table*

**REGIS**  
Tappeto - *Carpet*



**TANYA**  
Poltroncina - *Armchair*

**NOMOS SHAPED**  
Cassettiera - *Chest of drawers*

**REGIS**  
Tappeto - *Carpet*







## 01. RÉVERIE

Letto cm 223x230 H.129. Rivestimento esterno sommier e retro testata in pelle Soft Leather 1130 Neve. Rivestimento interno sommier e fronte testata tessuto Brasilia 24264/01 Panna. Filetti in pelle Soft Leather 1184 Peltro. Basamento in legno laccato nero lucido con angolari decorativi in ottone nichel nero satinato. Cuscino decorativo cm 30x50. Rivestimento in tessuto Falcade 24276/07 Sabbia con filetto Falcade 24276/08 Antracite. Cuscino decorativo cm 30x50. Rivestimento in tessuto Falcade 24276/02 Silver con filetto Falcade 24276/07 Sabbia. Cuscino decorativo cm 30x50. Rivestimento in tessuto Falcade 24276/08 Antracite con filetto Falcade 24276/07 Sabbia.

*Bed cm 223x230 H.129. Exterior of bedframe and rear headboard upholstered in Soft Leather 1130 Neve. Interior of bedframe and front headboard in fabric Brasilia 24264/01 Panna. Piping in Soft Leather 1184 Peltro. Plinth in black shiny lacquered wood with decorative brass corner elements in satin black nickel brass. Decorative cushion cm 30x50. Upholstery in Falcade 24276/07 Sabbia with pipings in Falcade 24276/08 Antracite. Decorative cushion cm 30x50. Upholstery in Falcade 24276/02 Silver with pipings in Falcade 24276/07 Sabbia. Decorative cushion cm 30x50. Upholstery in Falcade 24276/08 Antracite with pipings in Falcade 24276/07 Sabbia.*

## CHAMBRE CINQ

Copriletto in lino con trapuntatura cm 290x246. Set lenzuola con 2 federe in raso cotone cm 80x50. Set 2 federe in raso cotone supplementari cm 80x50. Plaid in lana cm 150x230 con frangia corta. Cuscino volante cm 30x40.

*Bedcover cm 290x246 in flax. Set of sheets with 2 pillow cases cm 80x50. Set of 2 additional pillow cases cm 80x50. Plaid in wool cm 150x230 with short fringe. Loose cushion cm 30x40.*

## 02. NOMOS SHAPED

Comodino a 2 cassetti cm 70x47 H.52. Corpo in legno laccato nero lucido. Top in marmo Invisible Grey. Base in acciaio nichel nero satinato.

*Bedside table with 2 drawers cm 70x47 H.52. Body in black lacquered wood. Top in Invisible Grey marble. Base in black nickel satin steel.*

## 03. NOMOS SHAPED

Cassettiera a 6 cassetti cm 250x60 H.75. Corpo in legno laccato nero lucido. Top in marmo Invisible Grey. Base in acciaio nichel nero satinato.

*Chest of 6 drawers cm 250x60 H.75. Top in Invisible Grey marble. Base in satin black nickel steel.*

## 04. TANYA

Poltroncina cm 76x66 H.76. Rivestimento esterno scocca in pelle Soft Leather 1132 col. nero. Rivestimento interno scocca in tessuto Chagall 24272/01 bianco/nero. Filetti pelle Soft Leather 1132 col. nero. Gambe in fusione di alluminio grigio metallizzato. Distanziali cilindrici e piedini in acciaio nichel nero lucido.

*Armchair cm 76x66 H.76. Exterior upholstered in Soft Leather 1132 col. nero. Interior upholstered in fabric Chagall 24272/01 bianco/nero. Piping in Soft Leather 1132 col. nero. Legs in aluminum cast matt-metal anthracite painted. Spacers and tips in black nickel steel.*

## 05. RUPERT

Tavolino basso ovale cm 140x94 H.35. Base in marmo massello Invisible Grey. Top in legno con incavo superiore laccato nero lucido. Profilo di base in acciaio nichel nero satinato.

*Oval low table cm 140x94 H.35. Base in solid Invisible Grey marble. Top in MDF with concave compartment in shiny black lacquer. Support base in satin black nickel steel.*

## 06. EUCLIDE

Lampada da tavolo cm 30x6 H.30. Corpo lampada interamente in marmo Calacatta Oro con diffusore interno in onice bianco. Sorgente a LED.

*Table lamp cm 30x6 H.30. Body in Calacatta Gold marble with internal diffuser in white onyx. LED lighting.*

## 07. EUCLIDE

Lampada da tavolo cm 45x8 H.30. Corpo lampada interamente in marmo Nero Marquina con diffusore interno in onice bianco. Sorgente a LED.

*Table lamp cm 45x8 H.30. Body in Nero Marquina marble with internal diffuser in white onyx. LED lighting.*

## 08. MADDY

Lampade a sospensione cm Ø8 H.23. In marmo Invisible Grey, ghiera in ottone nichel nero satinato.

*Suspended lamp cm Ø8 H.23. In Invisible Grey marble, ring in satin black nickel brass.*

## 09. FLOYD

Piantana cm Ø35 H.160. Paralume in vetro soffiato effetto acqua/latte, base e stelo in acciaio nichel nero satinato.

*Floor lamp cm Ø35 H.160. Lampshade in blown glass with water/milk effect. Base and stem in black nickel satin steel.*

## 10. FLOYD

Piantana cm Ø35 H.180. Paralume in vetro soffiato effetto acqua/latte, base e stelo in acciaio nichel nero satinato.

*Floor lamp cm Ø35 H.180. Lampshade in blown glass with water/milk effect. Base and stem in black nickel satin steel.*

## 11. MILO

Specchio rettangolare cm 90x4 H.220. Struttura perimetrale in acciaio nichel nero satinato, specchio colorato argento/rosa/azzurro.

*Rectangular mirror cm 90x4 H.220. Frame in black nickel satinized steel, in coloured mirror silver/pink/light blue.*

## 12. ANTHAR

Dormeuse sinistra cm 180x95 H.72. Fronte scocca e sedile in tessuto Ocean 24289/993 Pastello. Retro scocca in pelle Nabuk Maestrale 24127/3413 Nero. Zoccolo di base in legno laccato nero lucido. Incluso cuscino di schienale cm 70x50 in tessuto Ocean 24289/993 Pastello. Cuscini volanti cm 45x45. Rivestimento in tessuto Oban 24287/01 Grigio, filetti in Soft Leather 1184 Peltro. Cuscino volante cm 35x35. Rivestimento in fabric Douglas 24286/07 Sale e Pepe, filetti in Nabuk Maestrale 24127/3413 Nero.

*Left dormeuse cm 180x95 H.72. Front structure and seat in fabric Ocean 24289/993 Pastello. Rear structure in Nabuk Maestrale 24127/3413 Nero. Plinth in black shiny lacquered wood, including 1 loose cushion cm 70x50 in fabric Ocean 24289/993 Pastello. Loose cushion cm 45x45. Upholstery in fabric Oban 24287/01 Grigio, pipings in Soft Leather 1184 Peltro. Loose cushion cm 35x35. Upholstery in fabric Douglas 24286/07 Sale e Pepe, pipings in Nabuk Maestrale 24127/3413 Nero.*

## 13. REGIS

Tappeto cm 400x300.

*Carpet cm 400x300.*

## ART GALLERY

Arbor, cm 120x180. Cornice in acciaio champagne. Traccia 11. Busto in gesso (T-yong Chung). Traccia 12. Busto in gesso (T-yong Chung).

*Arbor, cm 120x180. Frame in polished champagne steel. Traccia 11. Gypsum bust (T-yong Chung). Traccia 12. Modified gypsum bust (T-yong Chung).*

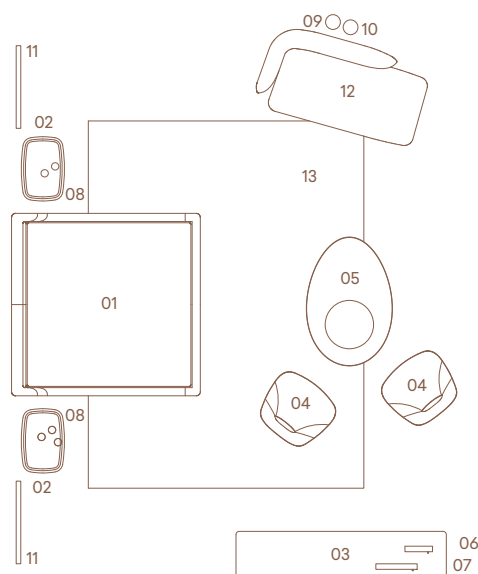



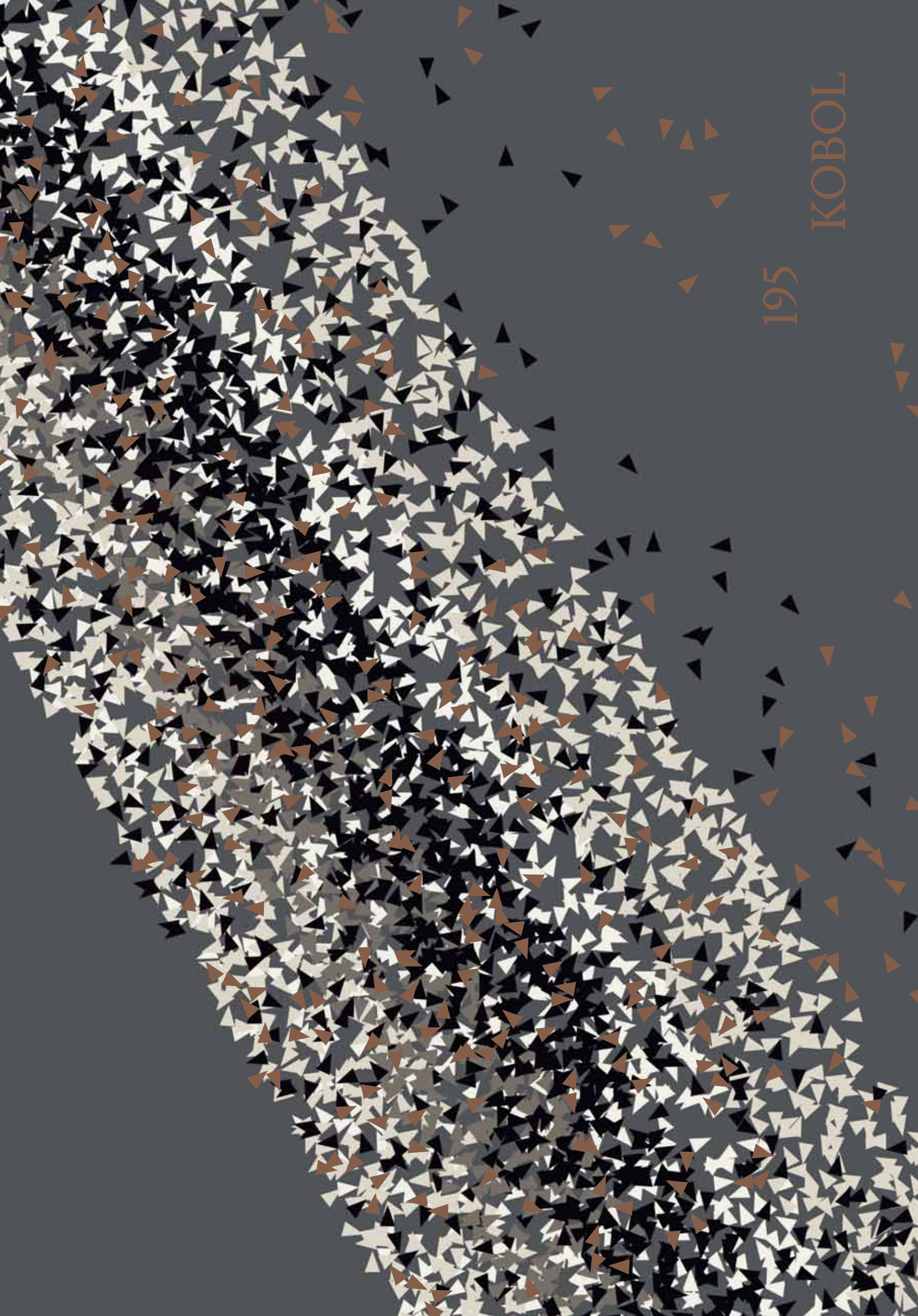

195 KOBOL











**KOBOL**  
Mobile portalavabo singolo - *Console with single basin*

**KOBOL**  
Specchio - *Mirror*

**KOBOL**  
Portasciugamani - *Towel holder*



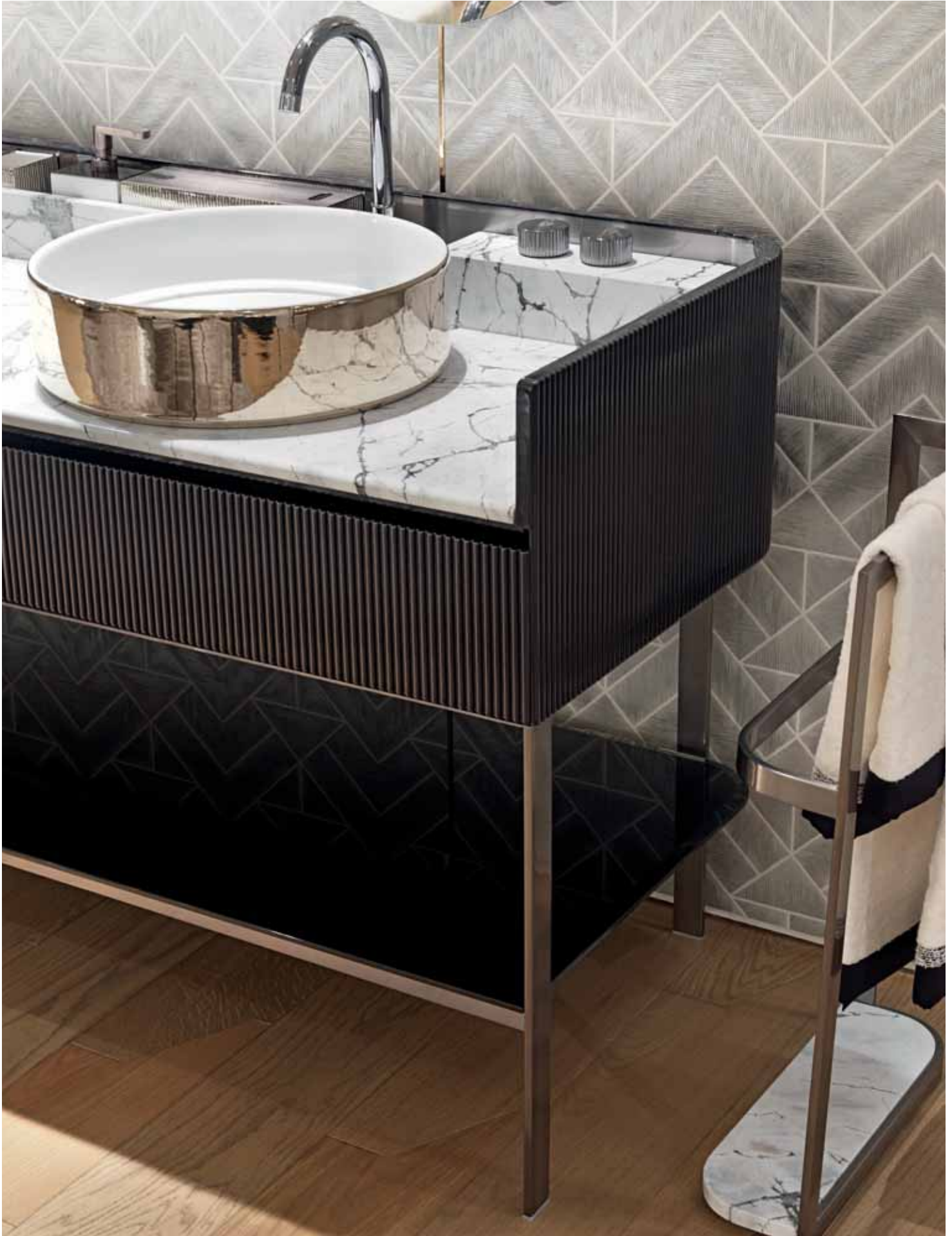

**KOBOL**  
Portavabo doppio - Console with double basin



**KOBOL**  
Mobile portalavabo singolo - Console with single basin



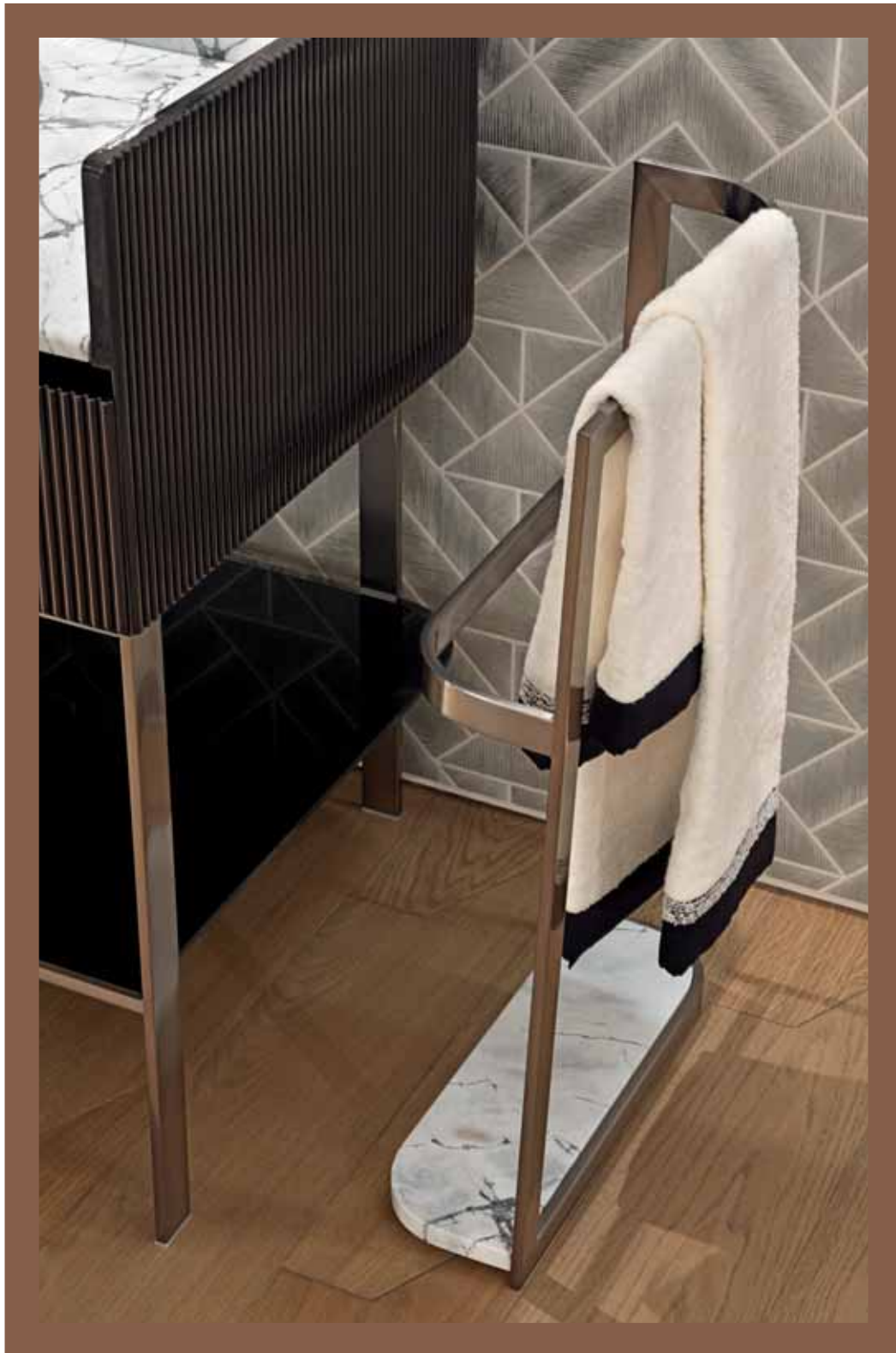

**KOBOL**  
Portasciugamani - *Towel holder*

**CHAMBRE CINQ**  
Set di asciugamani - *Set of bath clothing*







#### 01. KOBOL

Consolle lavabo doppio cm 200x65 H.90. Scocca e frontali cassetti in legno scanalato in finitura B.182 lucido. Struttura in acciaio nichel nero satinato. Top sagomato in marmo Invisible Grey, ripiano in vetro nero. Set rubinetteria in ottone nichel nero satinato. Lavabo tondo cm Ø45 H.13, in ceramica platino con interno bianco.

*Double washbasin console cm 200x65 H.90. Structure and front drawers in groove wood in B.182 shiny finishing. Legs in black nickel satinized steel. Shaped top in Invisible Grey marble, shelf in tempered black glass. Set of taps and faucet in black nickel satinized brass. Round sink cm Ø45 H.13 in platinum ceramic white inside.*

#### 02. KOBOL

Specchio ovale cm 46x104 sp. cm 3. Specchio molato con schienale in legno nero. Elementi decorativi in ottone nichel nero satinato.

*Mirror cm 46x104 th. cm 3. Grinded mirror with back in black wood. Decorative elements in black nickel brass.*

#### 03. KOBOL

Porta-asciugamani cm 44x14 H.75. Struttura in acciaio Nichel nero satinato. Base zavorra in marmo Invisible Grey.

*Towel holder cm 44x14 H.75. Structure in black nickel satinized steel. Base in Invisible Grey marble.*

#### 04. KOBOL

Scatola multiuso cm 30x8,5 H.11. Corpo in ceramica scanalata platino con interno bianco. Griglie porta-sapone o cover in acciaio liscio nichel nero satinato.

*Box cm 30x8,5 H.11, in grooved ceramic platinum and internal white. Soap holding grid or plain cover in black nickel satinized steel.*

#### 05. KOBOL

Scatola singola cm 10,5x8,5 H.11. Corpo in ceramica scanalata platino con interno bianco. Cover con accessorio dispenser per sapone in ottone nichel nero satinato.

*Box cm 10,5x8,5 H.11. Body in grooved ceramic platinum and internal white. Cover with soap dispenser in black nickel satinized brass.*

#### 06. AKIRA

Applique singola cm 27x20 H.35. Struttura in ottone nichel nero satinato. Paralume in tessuto Sanremo 24253/01 Gesso e interno in tessuto moirè.

*Single wall lamp cm 27x20 H.35. Structure in black nickel satinized brass. Lampshade in fabric Sanremo 24253/01 Gesso and internal in moirè fabric.*

#### CHAMBRE CINQ

Set di asciugamani, 100% spugna di cotone con ricamo su bordo in raso di cotone a contrasto, cm 40x60 e 60x110.

*Set of bath towels, 100% cotton terry with embroidery on edge in contrasting cotton satin, cm 40x60 and cm 60x110.*

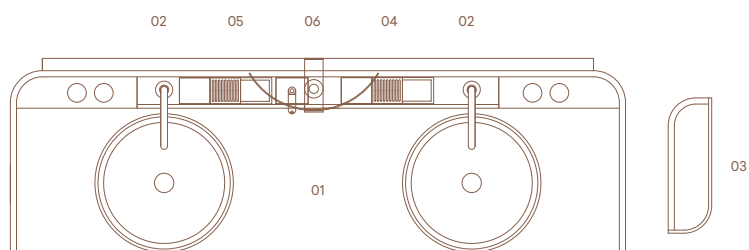



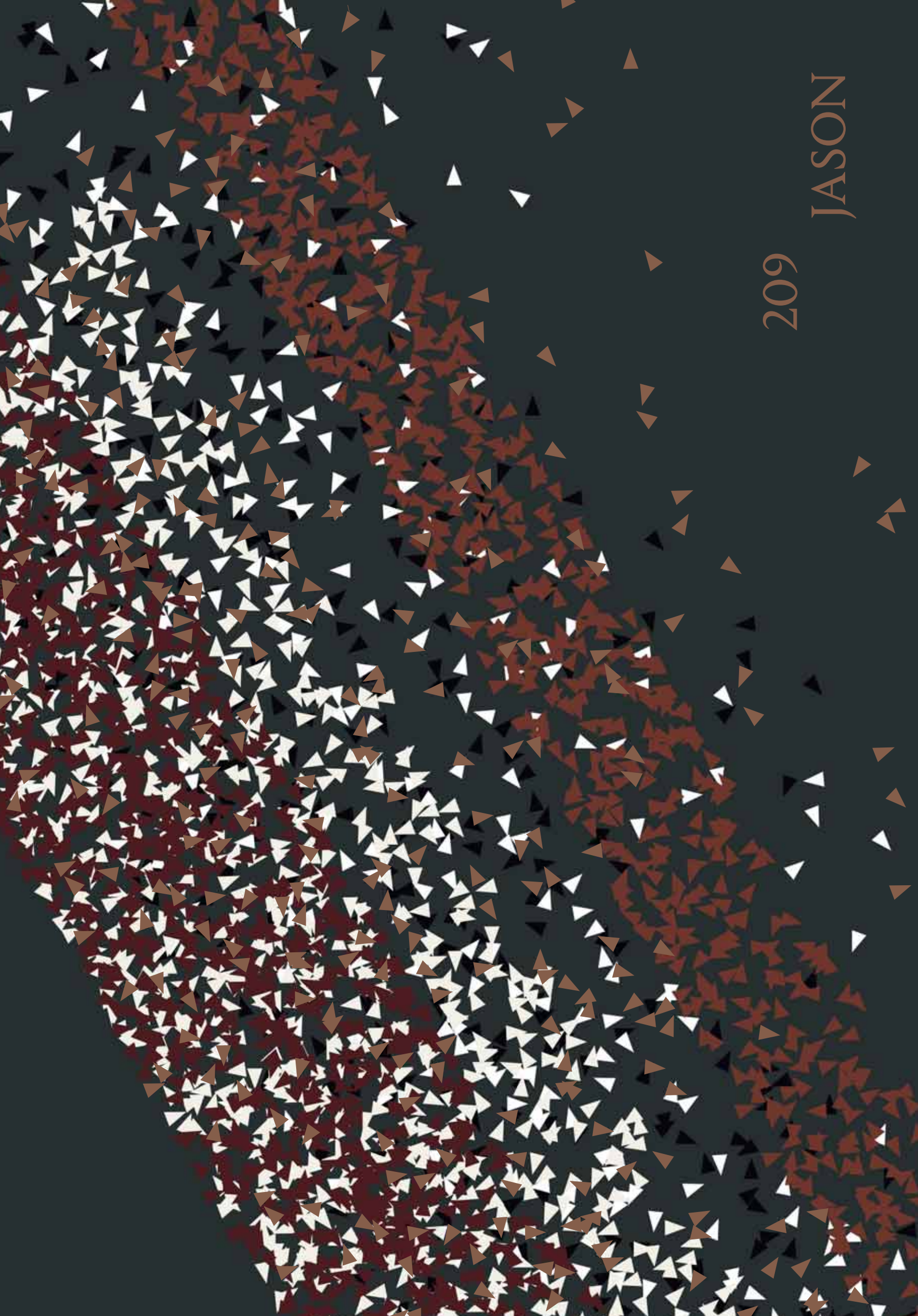

209

JASON







**JASON**  
Tavolo da pranzo - Dining table

**NOMOS SHAPED**  
Mobile bar - Bar cabinet

**TANYA**  
Sedia - Chair

**KUIPER**  
Tappeto - Carpet













**JASON**  
Tavolo da pranzo - *Dining table*

**SYLAR**  
Plafoniera - *Ceiling light*

**KUIPER**  
Tappeto - *Carpet*















**TANYA**  
Sedia - *Chair*

**KUIPER**  
Tappeto - *Carpet*





CATTEDRALE N57  
CATTEDRALE N58  
CATTEDRALE N59  
Art gallery

**ELDER**  
Lampada da tavolo - *Table lamp*

**NOMOS SHAPED**  
Mobile con ante - *Cabinet*







NOMOS SHAPED  
Mobile con ante - Cabinet









NOMOS SHAPED  
Mobile bar - Bar cabinet





**NOMOS SHAPED**  
Mobile bar - Bar cabinet

**KRAKEN**  
Posacenere - Ashtray



CUSTODE SAMURAI VIII  
Art gallery





### 01. JASON

Tavolo da pranzo ovale cm 300x134 H.75. Top in mosaico di marmo in tre tipologie: Invisible Grey, Rosso Levante Turco, Verde Rameggiato, con intarsio in acciaio. Sottotop in legno laccato nero lucido. Basamento in cuoio Kenya Matt 24164/08 Dark Chocolate sp. mm 3. Profili decorativi in acciaio nichel nero satinato.

*Oval dining table cm 300x134 H.75. Top in marble mosaic made of: Invisible Grey, Rosso Levante Turco, Verde Rameggiato, with steel inlay. Undertop in black lacquered wood. Base covered with cuoio leather Kenya Matt 24164/08 Dark Chocolate th. mm 3. Decorative profiles in black nickel satinized steel.*

### 02. TANYA

Sedia imbottita cm 64x57 H.81. Rivestimento in pelle Levante 24278/42 Ghiaccio. Filetti in pelle Soft Leather 1184 Peltro. Gambe in fusione di alluminio grigio metallizzato. Distanziali cilindrici e piedini in acciaio nichel nero lucido.

*Chair cm 64x57 H.81. Upholstery in leather Levante 24278/42 Ghiaccio. Pipings in Soft Leather 1184 Peltro. Legs in aluminum cast matt-metal anthracite painted. Spacers and tips in black nickel steel.*

### 03. NOMOS SHAPED

Mobile contenitore a 4 ante cm 250x60 H.83. Corpo in legno laccato nero lucido. Top in marmo Invisible Grey. Base in acciaio nichel nero satinato. Frontale cassetto interno rivestito in cuoio Kenya 24164/02 Betulla.

*Cabinet with 4 doors cm 250x60 H.83. Body in black lacquered wood. Top in Invisible Grey marble. Base in black nickel satinized steel. Front panel of the internal drawer covered in Kenya leather 24164/02 Betulla.*

### 04. NOMOS SHAPED

Mobile bar a 4 ante cm 110x52 H.135. Corpo in legno laccato nero lucido. Top in marmo Invisible Grey. Base in acciaio nichel nero satinato.

*Bar cabinet with 2 doors cm 110x52 H.135. Body in black lacquered wood. Top in Invisible Grey marble, base in black nickel satinized steel.*

### 05. SYLAR

Lampadario/plafoniera ovale cm 188x63 H.53. Maglia di cristallo con struttura in acciaio nichel nero satinato. Optional: sistema audio bluetooth.

*Oval chandelier/ceiling light cm 188x63 H.53. Crystal mesh with main structure in black nickel satinized steel.*

### 06. ELDER

Lampada da tavolo cm Ø45 H.59. Base in marmo Verde Rameggiato, stelo in acciaio nichel nero satinato e smalto nero, paralume in scaglie di alluminio nero.

*Table lamp cm Ø45 H.59. Base in Verde Rameggiato marble, stem in black nickel satinized steel and black laquer, lampshade with black aluminium plates.*

### 07. KUIPER

Tappeto cm 400x300.

*Carpet cm 400x300.*

### ART GALLERY

Cattedrale N57, cm 70x90.

Cattedrale N58, cm 70x90.

Cattedrale N59, cm 70x90.

Custode della Luce cm 32x33 H.41 Kg.50.

Marmo Portoro nero. (Matteo Pugliese)

*Custode della Luce cm 32x33 H.41 Kg.50. Portoro nero marble. (Matteo Pugliese)*

Custode Samurai VIII cm 38x29 H.45 Kg.50.

Marmo Nero Marquina. (Matteo Pugliese)

*Custode Samurai VIII cm 38x29 H.45 Kg.50. Nero marquina marble. (Matteo Pugliese)*

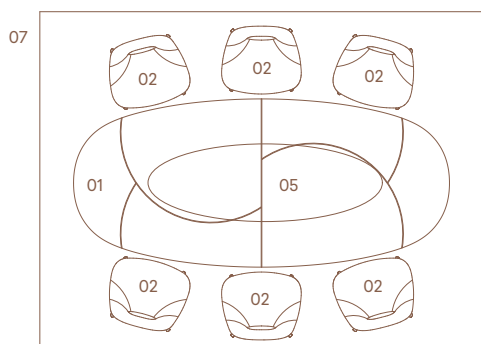
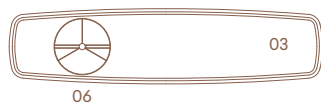

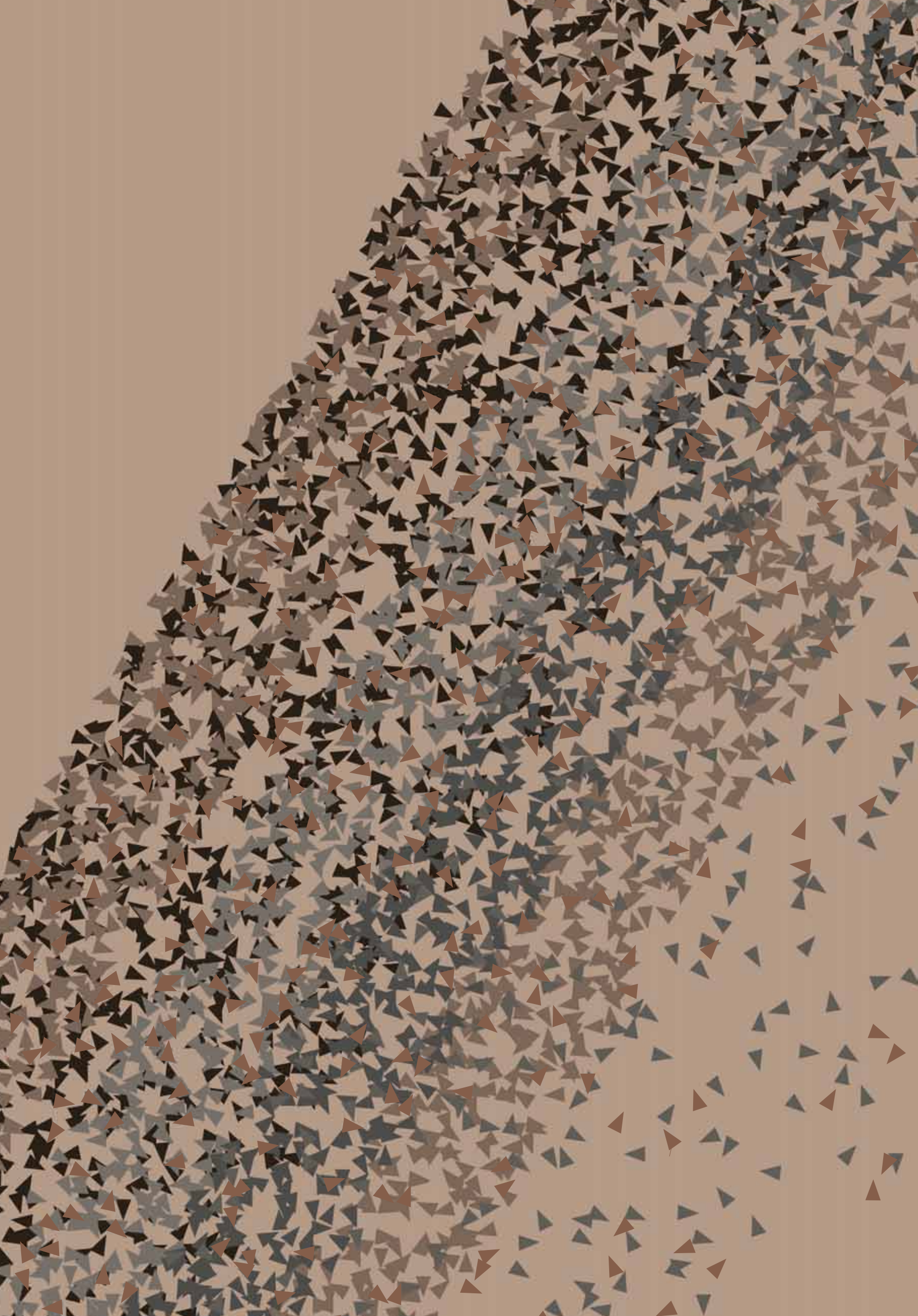



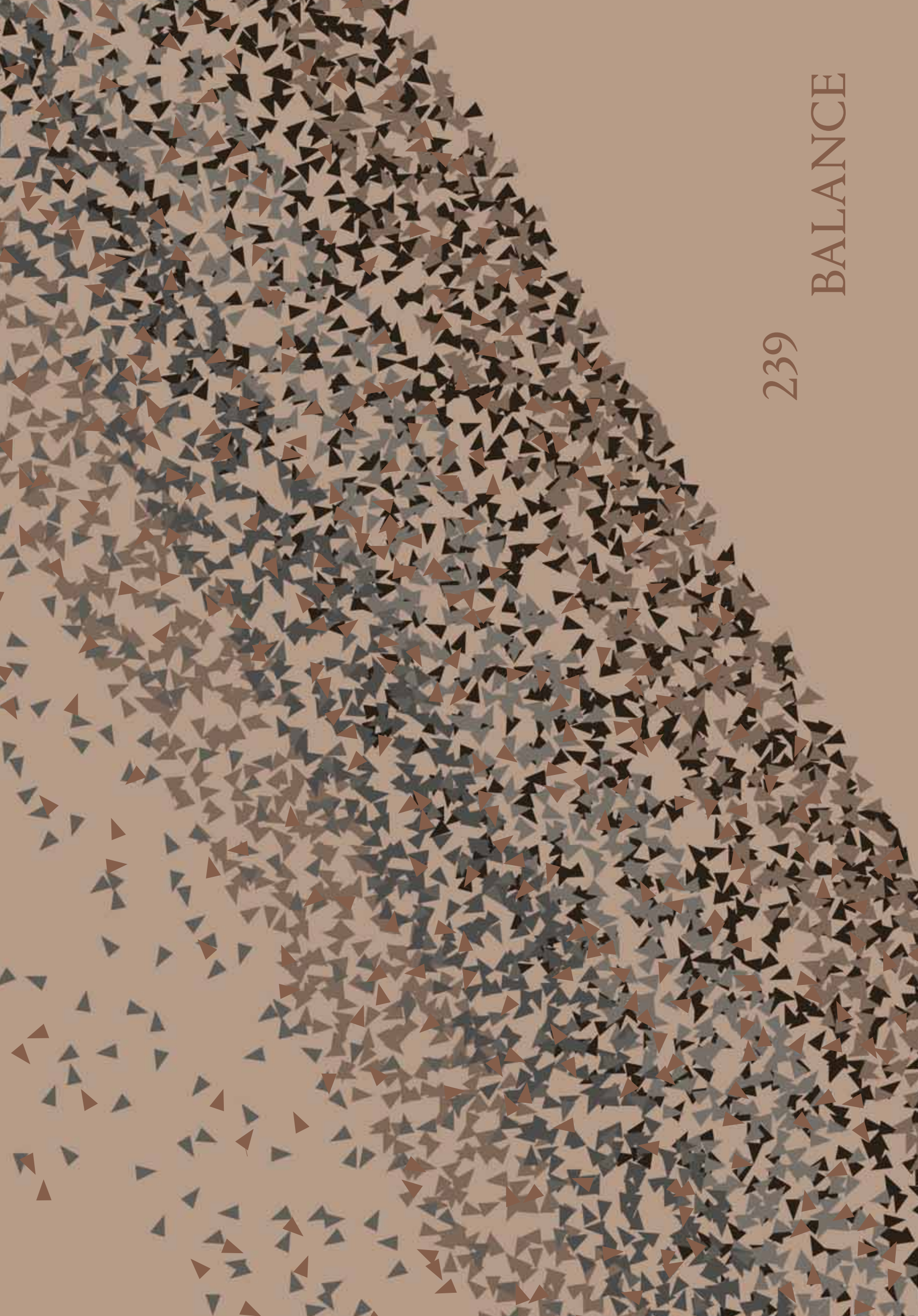

239

BALANCE



**BALANCE**  
Divano - *Sofa*

**BALANCE**  
Poltrona - *Armchair*

**MARTY**  
Tavolo basso - *Low table*

**GAIUS**  
Mobile bar - *Bar cabinet*

**TARTAN**  
Plaid



**GAYNOR**  
Libreria - Bookshelf

**BRONSON**  
Mobile basso - Low unit

**JABBA**  
Lampadario - Chandelier

**FLOYD**  
Piantana - Floor lamp















**BALANCE**  
Divano - Sofa

**TAGORA**  
Tappeto - Carpet



**BALANCE**  
Divano - Sofa

**MARTY**  
Tavolo basso - Low table







**BRONSON**  
Mobile basso - *Low cabinet*

**KALLIMA**  
Art gallery

**BALANCE**  
Poltrona - *Armchair*

**GAIUS**  
Mobile bar - *Bar cabinet*

**JABBA**  
Lampadario - *Chandelier*



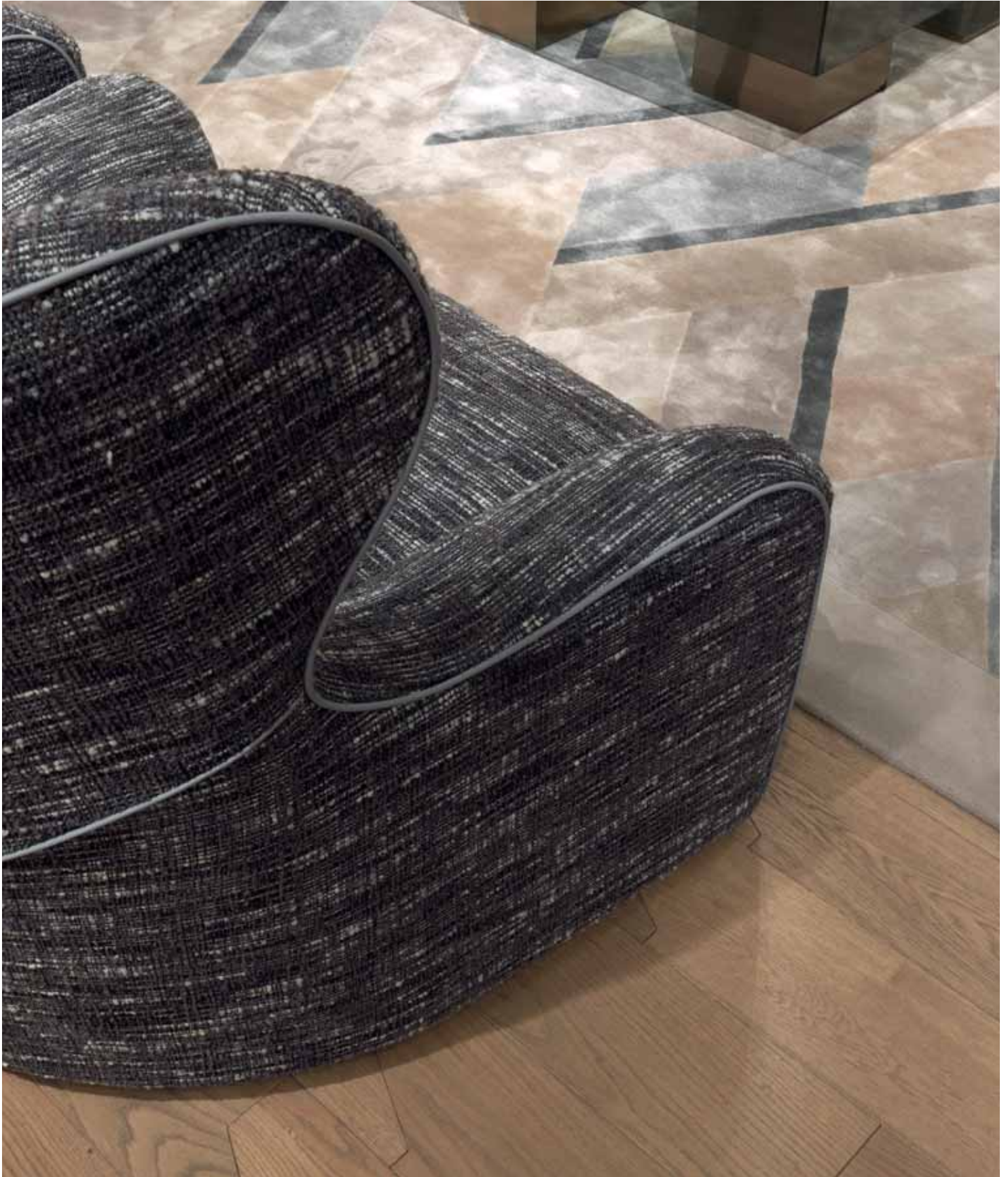

**BALANCE**  
Poltrona - *Armchair*

**TAGORA**  
Tappeto - *Carpet*





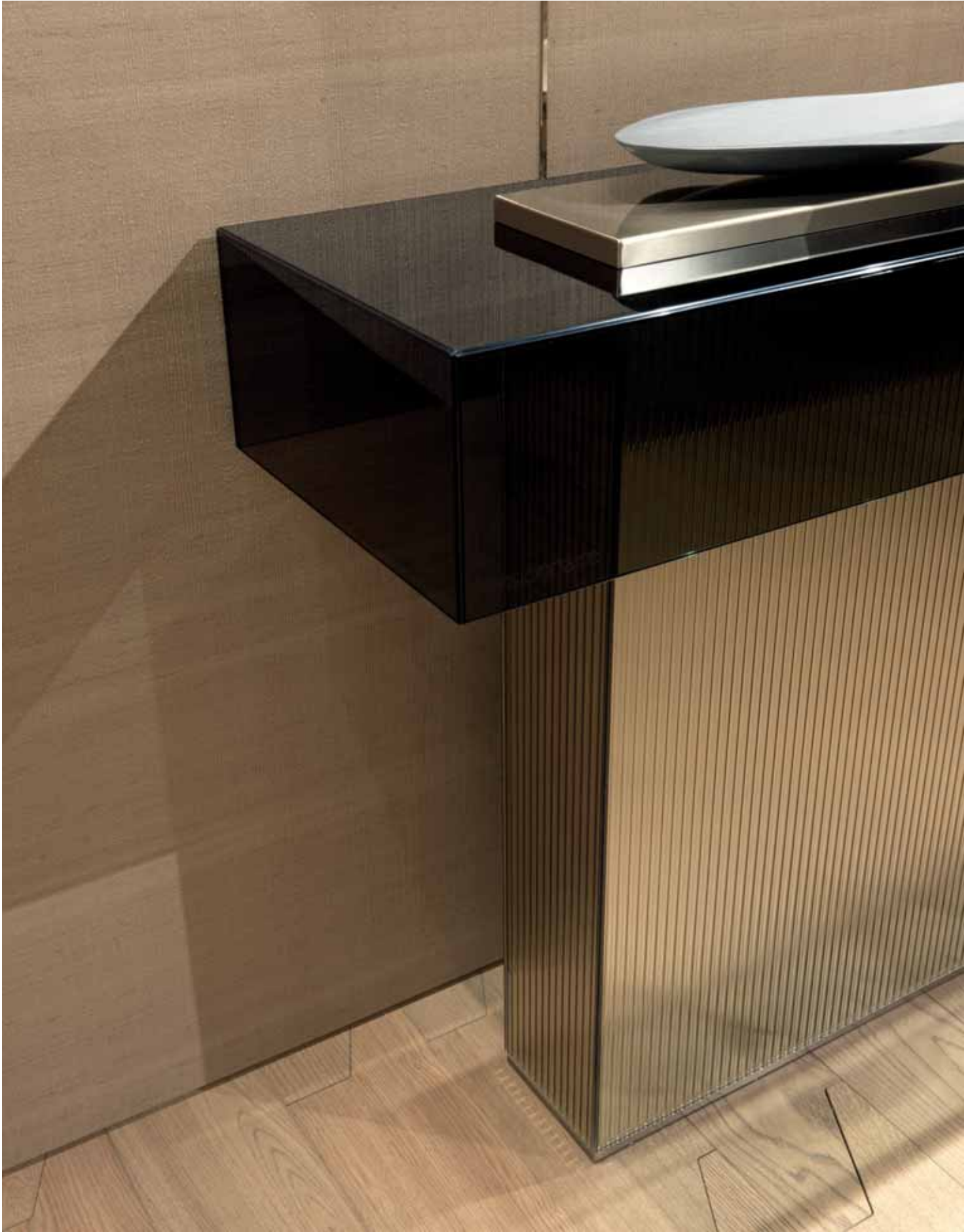

**MARTY**  
Consolle - Console

**SENZA TITOLO - UNTITLED**  
Art gallery









**GAYNOR**  
Libreria - Bookshelf

**FLOYD**  
Piantana - Floor lamp





**AIRONI**  
Vaso - Vase

**ALI DISCHIUSE**  
Vaso - Vase

**TARTARUGA**  
Vaso - Vase







**BRONSON**  
Mobile basso - *Low cabinet*

**LYDIA**  
Lampada da tavolo - *Table lamp*

**KALLIMA**  
Art gallery



**LYDIA**  
Lampada da tavolo - *Table lamp*

**BRONSON**  
Mobile basso - *Low cabinet*





**GAIUS**  
Mobile bar - *Bar cabinet*

**TARTAN**  
Plaid





**GAIUS**  
Mobile bar - Bar cabinet







### 01. BALANCE

Divano cm 300x117 H.95. Rivestimento in pelle Malta 24261/ 09 Mercurio, filetti pelle Soft Leather 1184 Peltro. Cuscinatura schienale in pelle Malta 24261/ 09 Mercurio e filetti pelle Soft Leather 1184 Peltro. Base in acciaio champagne satinato.

*Sofa cm 300x117 H.95. Upholstery in leather Malta 24261/ 09 Mercurio, pipings in Soft Leather 1184 Peltro. Back cushions in leather Malta 24261/ 09 Mercurio with pipings in Soft Leather 1184 Peltro. Base in champagne satinized steel.*

### 02. BALANCE

Divano cm 300x117 H.95. Rivestimento in pelle Malta 24261/09 Mercurio, filetti pelle Soft Leather 1184 Peltro. Cuscinatura schienale in tessuto Empire 24179/08 Peltro e filetti pelle Soft Leather 1184 Peltro. Base in acciaio champagne satinato.

*Sofa cm 300x117 H.95. Upholstery in leather Malta 24261/09 Mercurio with pipings in Soft Leather 1184 Peltro. Back cushions in fabric Empire 24179/08 Peltro with pipings in Soft Leather 1184 Peltro. Base in champagne satinized steel.*

### 03. BALANCE

Poltrona cm 110x117 H.95. Rivestimento in tessuto Campitello 24293/90 Bistro, filetti pelle Soft Leather 1184 Peltro. Base in acciaio champagne satinato.

*Armchair cm 110x117 H.95. Upholstery in fabric Campitello 24293/90 Bistro with pipings in Soft Leather 1184 Peltro. Base in champagne satinized steel.*

### TARTAN

Plaid, cm 230x140.

### 04. MARTY

Tavolo basso cm 120x120 H.42 a 3 basi. Top principale in cristallo fumè. Base cm 80x20 in marmo Elegant Dune con cover di finitura acciaio oro satinato. Base cm 50x20 in acciaio oro satinato con cover di finitura in marmo Elegant Dune. Base cm 27x27 in acciaio oro satinato con cover di finitura in marmo Elegant Dune.

*Low table cm 120x120 H.42 with 3 bases. Main top in smoked glass. Base cm 80x20 in Elegant Dune marble with upper cover in gold satinized steel. Base cm 50x20 in gold satinized steel with upper cover in Elegant Dune marble. Base cm 27x27 in gold satinized steel with upper cover in Elegant Dune marble.*

### 05. MARTY

Consolle in vetro cm 160x40 H.97. Top principale in cristallo fumè. Coppia di basi in specchio bronzo con superficie cannettata in rilievo, con cover di finitura in acciaio champagne satinato.

*Glass console cm 160x40 H.97. Smoked crystal top. Two bases in bronze mirror with embossed surface in relief with upper cover in gold satinized steel.*

### 06. BRONSON

Mobile basso con ante e cassetto cm 250x57 H.72. Struttura placcata essenza B.182 lucido. Frontale cassetto e inserto top in marmo Elegant Dune, fianco rientrato e interni laccati Ral 7015 lucido. Maniglie in acciaio champagne satinato. Base in acciaio champagne satinato.

*Low cabinet with doors and drawer cm 250x57 H.72. Structure in veneered wood B.182, shiny finishing. Front drawer and top insert in marble Elegant Dune. Shaped side and interior in shiny Ral 7015 laquer. Handles in champagne satinized steel. Plinth in champagne satinized steel.*

### 07. FLOYD

Piantana cm Ø35 H.160. Paralume in vetro soffiato effetto tartaruga, base e stelo in acciaio champagne satinato.

*Floor lamp cm Ø35 H.160. Lampshade in blown glass with turtle effect. Base and stem in champagne satin steel.*

### 08. FLOYD

Piantana cm Ø35 H.180. Paralume in vetro soffiato effetto tartaruga, base e stelo in acciaio champagne satinato.

*Floor lamp cm Ø35 H.180. Lampshade in blown glass with turtle effect. Base and stem in champagne satin steel.*

### 09. JABBA

Lampadario cm 125x70 H.185. Struttura in acciaio cromo lucido, drappo in placche di alluminio champagne.

*Chandelier cm 125x70 H.185. Structure in shiny chromed steel, with drape aluminium plates chains in champagne aluminium.*

### 10. GAIUS

Mobile bar cm 80x44 H.131. Struttura con ante in cristallo temperato fumè, box interno in essenza legno B.182 lucido. Base acciaio champagne satinato con stelo in metallo placcato in essenza B.182 lucido. Maniglie a pendaglio in ottone champagne satinato.

*Bar cabinet cm 80x44 H.131. Structure with doors in smoked tempered glass, internal box in glossy veneered wood B.182. Base in champagne satinized steel with metal stem in veneer B.182. Pendant brass handles in champagne satinized finishing.*

### 11. GAYNOR

Libreria componibile cm 340x42 H.250. Spalle in essenza A.721 lucido. Schienali, ripiani, ante e frontali cassetti in pelle Taras 24296/25 Seppia. Ante in cristallo temperato fumè con maniglia in ottone champagne satinato. Interni laccati Ral 7037 opaco. Profili e base in acciaio champagne satinato.

*Bookshelf cm 340x42 H.250. Sides in glossy veneered wood A.721. Back, shelves, doors and front drawers in leather Taras 24296/25 Seppia. Doors in smoked tempered glass with knob in champagne satinized brass. Interiors lacquered Ral 7037, mat finishing. Profiles and base in champagne satinized steel.*

### 12. LYDIA

Lampada da tavolo cm Ø50 H.53. Stelo scolpito in massello di marmo Elegant Dune. Base e paralume in acciaio champagne satinato.

*Table lamp cm Ø50 H.53. Stem in shaped solid Elegant Dune marble. Lampshade and base in champagne satinized steel.*

### 13. TAGORA

Tappeto cm 400x300.  
Carpet cm 400x300.

### ART GALLERY

Kallima cm 130x140.  
Cornice in acciaio champagne.

*Kallima cm 130x140.  
Frame in polished champagne steel.*

Senza Titolo, cm 120x120.  
Lastra in gres dipinta a mano.  
(Maurizio Cannavacciuolo).

*Untitled, cm 120x120.  
Hand-painted porcelain slab  
(Maurizio Cannavacciuolo).*

### AIRONI

Vaso Veronese cm H.58.  
Veronese Vase cm H.58.

### ALI DISCHIUVE

Vaso Veronese cm H.65.  
Veronese Vase cm H.65.

### TARTARUGA

Vaso Veronese cm H.50.  
Veronese Vase cm H.50.

### HORNY

Vaso porta candela cm Ø19 H.24.  
Candle-holder vase cm Ø19 H.24.

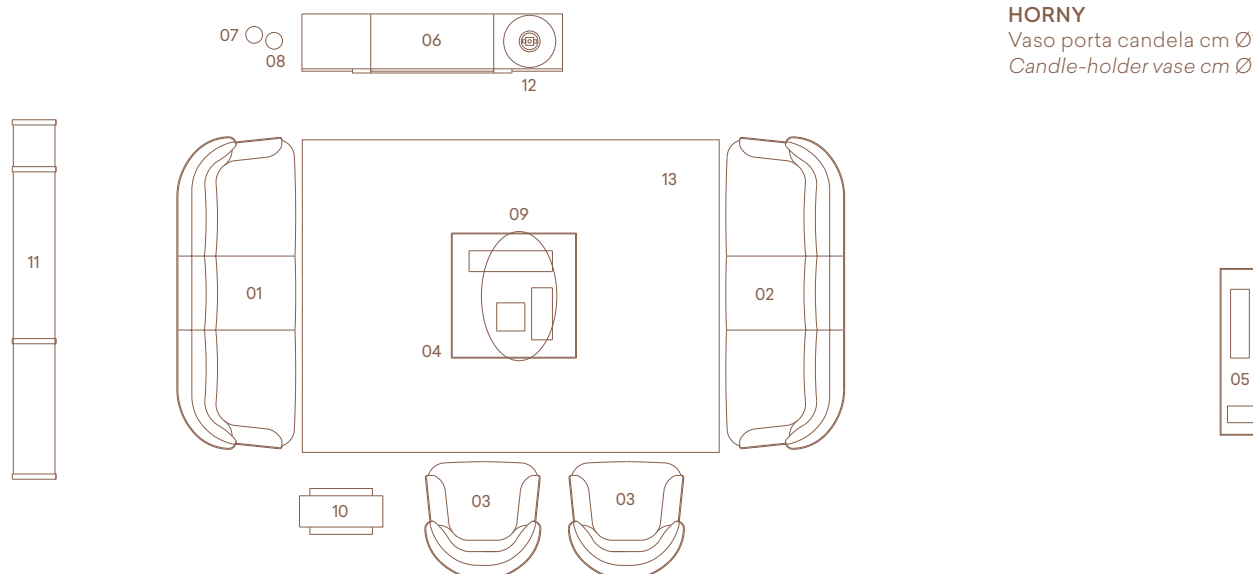

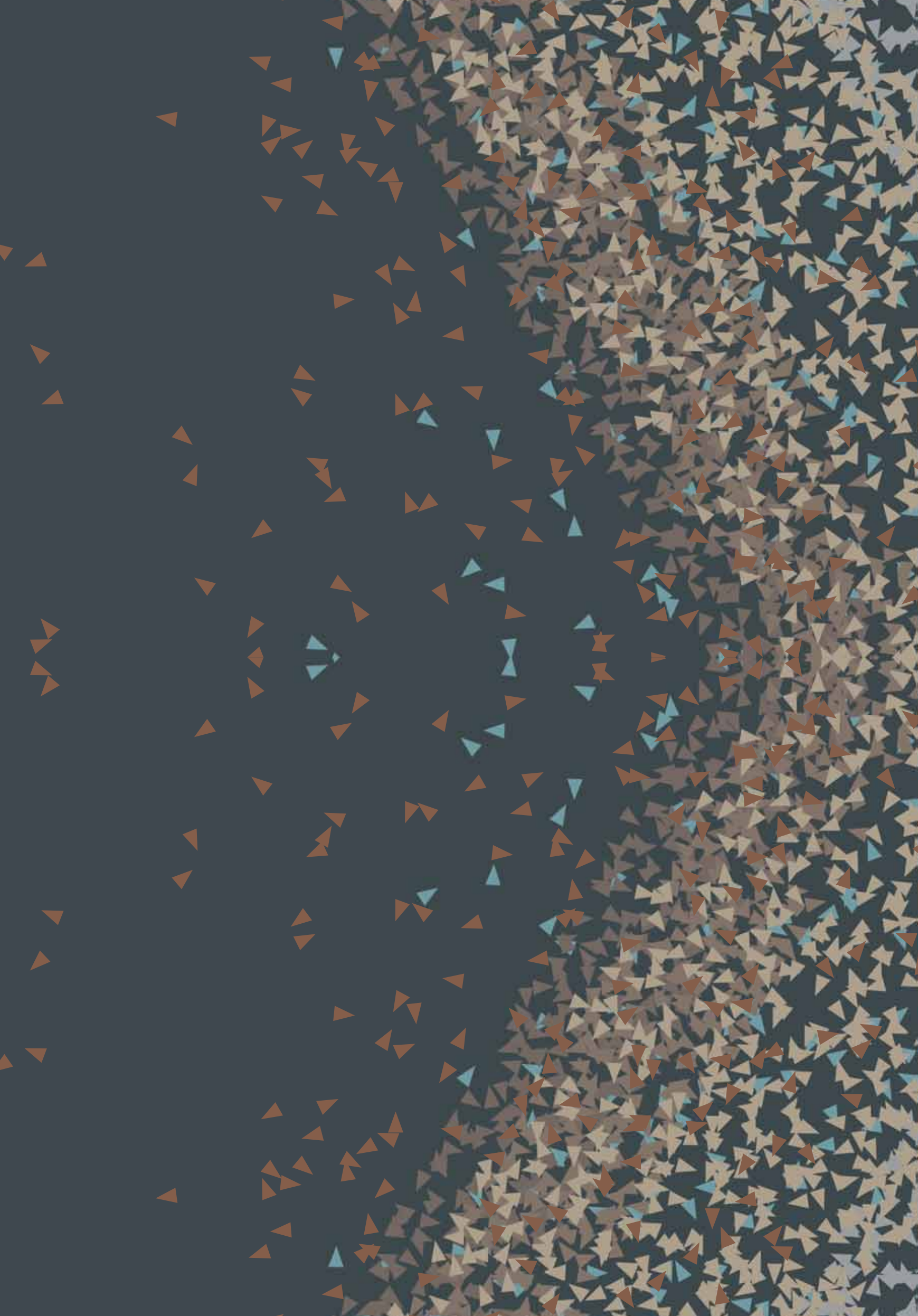

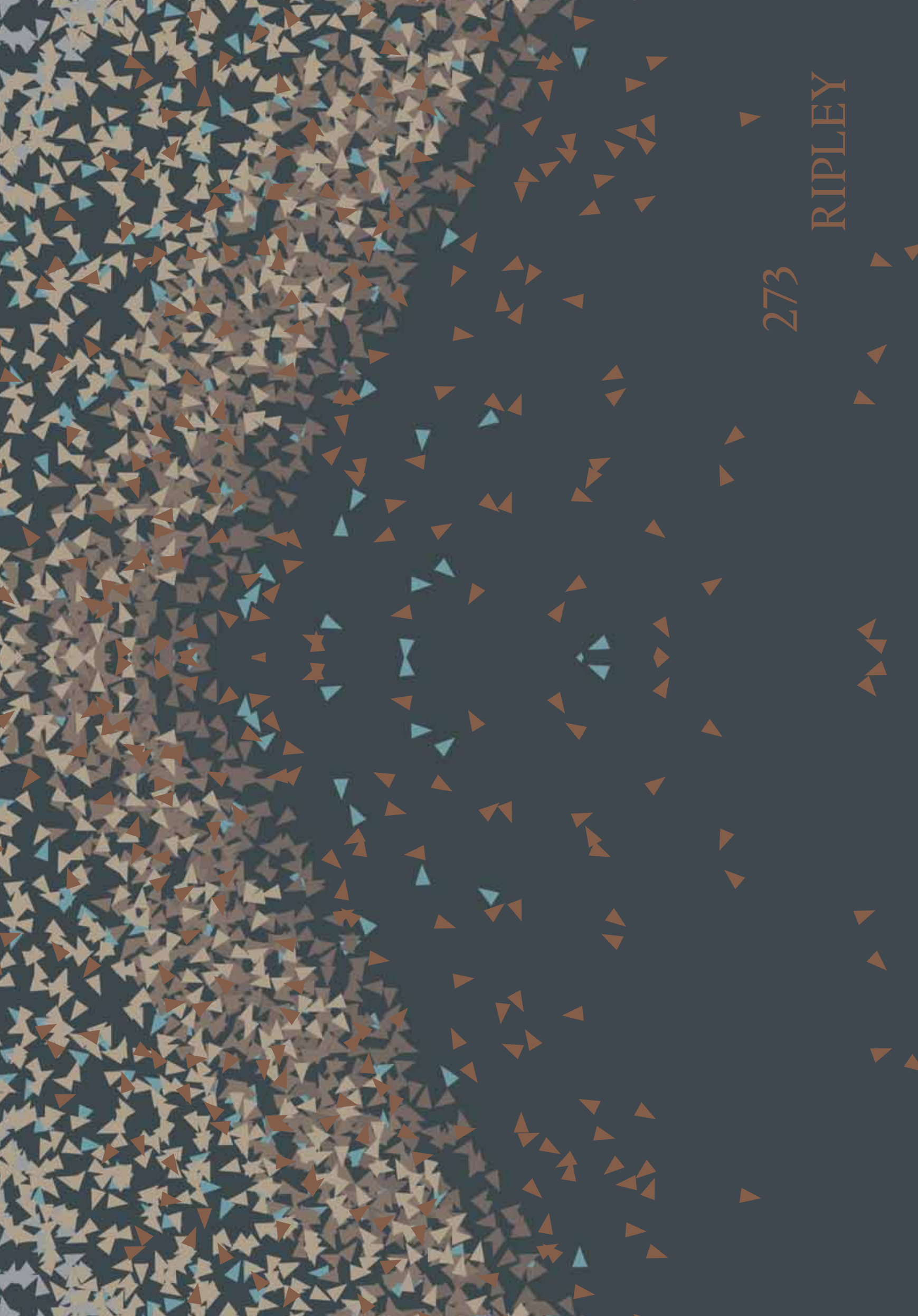

273

RIPLEY

















**RIPLEY**  
Letto - *Bed*

**SKIBA**  
Comodino - *Bedside table*

**BINKLEY**  
Tappeto - *Carpet*

**JORGE**  
Panca con contenitore - *Bench with container*

**JASPER**  
Lampada da tavolo - *Table lamp*





**BARNEY**  
Cassettiera - Chest of drawers

**SENZA TITOLO - UNTITLED**  
Art gallery



**SHAILA**

Lampada da tavolo - *Table lamp*

**LEGEND QUILTED**

Poltrona - *Armchair*



**RIPLEY**  
Letto - *Bed*

**EPOQUE**  
Set di lenzuola - *Set of sheets*









**JORGE**  
Panca con contenitore -  
*Bench with container*

**BINKLEY**  
Tappeto - *Carpet*



**JASPER**  
Lampada da tavolo - *Table lamp*

**SKIBA**  
Comodino - *Bedside table*



**WESTLEY**  
Mobile trucco - *Make-up unit*

**WESTLEY**  
Specchio - *Mirror*

**ANASTASIA**  
Poltroncina - *Armchair*

**WINX**  
Cofanetto - *Case*















**ANASTASIA**  
Poltroncina - Armchair









**SHAILA**  
Lampada da tavolo - *Table lamp*

**BARNEY**  
Cassettiera - *Chest of drawers*



**LEGEND QUILTED**  
Poltrona - Armchair

## 01. RIPLEY

Letto cm 360x224 H.115. Parte centrale testata trapuntata in pelle Nabuk Maestrale 24127/101 Ardesia. Fianchi testata in velluto Gand/intreccio 24275/03 Creta. Cornice perimetrale in velluto Gand 24275/03 Creta. Luce di cortesia a LED sui fianchi testata con interruttori a sfioramento. Sommier rivestito in velluto Gand 24275/03 Creta. Particolari in acciaio oro satinato.

*Bed cm 360x224 H.115. Central headboard with quilted pattern in Nabuk Maestrale 24127/101 Ardesia. Sides of headboard in fabric Gand/intreccio 24275/03 Creta. Frame in fabric Gand 24275/03 Creta. Courtesy LED light on the sides of the headboard with touch sensor. Bed base in fabric Gand 24275/03 Creta. Details in gold satinized steel.*

## EPOQUE

Copriletto in raso cm 270x270. Set lenzuola con 2 federe in lino cm 80x50. Set 2 federe in lino supplementari cm 80x50. Plaid in cachemire con frangia cm 150x210.

*Bedcover in satin cm 270x270. Set of sheets with 2 pillow cases in linen cm 80x50. Additional set of 2 pillow cases in linen cm 80x50. Plaid in cachemire with fringe cm 150x210.*

## 02. SKIBA

Comodino cm 60x40 H.50. Top in essenza B.181 Fiammato Sabbia lucido. Rivestimento in pelle Malta 2426/05 Camoscio. Interno cassetto laccato Ral 8022 opaco, zoccolo in acciaio oro satinato.

*Bedside table cm 60x40 H.50. Top in glossy veneered wood B.181 Fiammato Sabbia. Upholstery in leather Malta 2426/05 Camoscio. Internal drawer in Ral 8022 mat lacquer. Base in gold satinized steel.*

## 03. JASPER

Lampada da tavolo cm 51x21 H.40. Base e stelo in ottone oro satinato. Stelo conico in marmo massello Calacatta Oro. Proiettore lineare in ottone con sorgente LED a luce calda.

*Table lamp cm 51x21 H.40. Base and stem in gold lacquered brass. Conical Stem in solid Calacatta Gold marble. Linear brass projector with warm LED light source.*

## 04. JORGE

Pouf contenitore apribile cm 140x40 H.40. Rivestimento superiore in Gand/intreccio 24275/03 Creta. Rivestimento laterale in tessuto Gand 24275/03 Creta. Interno laccato Ral 8022 opaco, zoccolo in acciaio oro satinato.

*Pouffe with container cm 140x40 H.40. Upper upholstery in Gand/intreccio 24275/03 Creta. Side upholstery in fabric Gand 24275/03 Creta. Internal parts in Ral 8022 mat lacquer. Base in gold satinized steel.*

## 05. BARNEY

Cassettiera a 9 cassetti cm 250x50 H.70. Top e struttura in essenza B.181 Fiammato Sabbia lucido. Rivestimento frontali cassetti in marmo Fior di Bosco, interno laccato nero opaco. Struttura di base e particolari in acciaio oro satinato.

*Chest of 9 drawers cm 250x50 H.70. Top and structure in veneered wood B.181 Fiammato Sabbia. Front drawers in Fior di Bosco marble, interiors in black mat lacquer. Base structure and details in gold satinized steel.*

## 06. LEGEND QUILTED

Poltrona cm 109x82 H.69. Rivestimento in Nabuk Maestrale 24127/101 Ardesia trapuntato. Cuscini di seduta e schienale in tessuto Lorooley 24284/23 ceruleo. Piedi posteriori in essenza B.181 Fiammato Sabbia, piedi anteriori in acciaio oro satinato. Cuscino volante cm 50x65. Rivestimento in Nabuk Maestrale 24127/101 Ardesia.

*Armchair cm 109x82 H.69. Main upholstery in Nabuk Maestrale 24127/101 Ardesia with quilting. Seat and backrest cushion upholstered in Lorooley 24284/23 ceruleo. Rear legs in veneered wood B.181 Fiammato Sabbia, front legs in gold satinized steel. Loose cushion cm 50x65. Upholstery in Nabuk Maestrale 24127/101 Ardesia.*

## 07. WESTLEY

Mobile trucco cm 230x59 H.73. Top in vetro fumè, gamba in legno rivestita in pelle Malta 24261/05 Camoscio con puntale in acciaio oro satinato. Cassettiera laterale rivestita in pelle Malta 24261/05 Camoscio a intreccio modello R67. Cassetti in essenza B.181 Fiammato Sabbia con interno laccato RAL 3005 opaco. Base e profili in acciaio oro satinato.

*Vanity unit cm 230x59 H.73. Top in smoked glass, wooden leg covered in leather Malta 24261/05 Camoscio with tip in gold satinized steel; chest of drawers in leather Malta 24261/05 Camoscio with interwoven pattern. Drawers in veneered wood B.181 Fiammato Sabbia and mat lacquered RAL 3005 inside. Base and profiles in gold satinized steel.*

## 08. WESTLEY

Specchiera luminosa a parete cm Ø180x4. Cornice in acciaio finitura lacca oro satinato con illuminazione perimetrale a LED, retro pannello in legno laccato RAL 9005 opaco.

*Mirror cm Ø180x4. Frame in gold satinized steel with perimetral LED lighting, rear panel in RAL 9005 mat lacquered wood.*

## 09. ANASTASIA

Poltroncina cm 59x57 H.78. Rivestimento integrale in cuoio Kenya 24164/11 Oceano, spessore mm 3.

*Small armchair cm 59x57 H.78. Entirely upholstered in cuoio leather Kenya 24164/11 Oceano, th. mm 3.*

## 10. GALAHAD

Lampadario a sospensione cm Ø80 H.175. Diffusore in scaglie di alluminio oro, struttura in acciaio galvanizzato.

*Chandelier cm Ø80 H.175. Body gold aluminium plates with internal structure in galvanized steel.*

## 11. SHAILA

Lampada da tavolo cm 23x45 H.68. Base in acciaio champagne lucido con maglia in scaglie alluminio oro. Paralume ellittico in seta nera.

*Table lamp cm 23x45 H.68. Base in shiny champagne steel with mesh in gold aluminium plates. Elliptical lampshade in black silk.*

## 12. BINKLEY

Tappeto cm 400x300.

*Carpet cm 400x300.*

## ART GALLERY

Senza Titolo, cm Ø120. Lastra in gres dipinta a mano, colore nero (Ral 9005) (Gianni Asdrubali).

*Untitled, cm Ø120. Hand painted porcelain slab, black color (Ral 9005) (Gianni Asdrubali).*

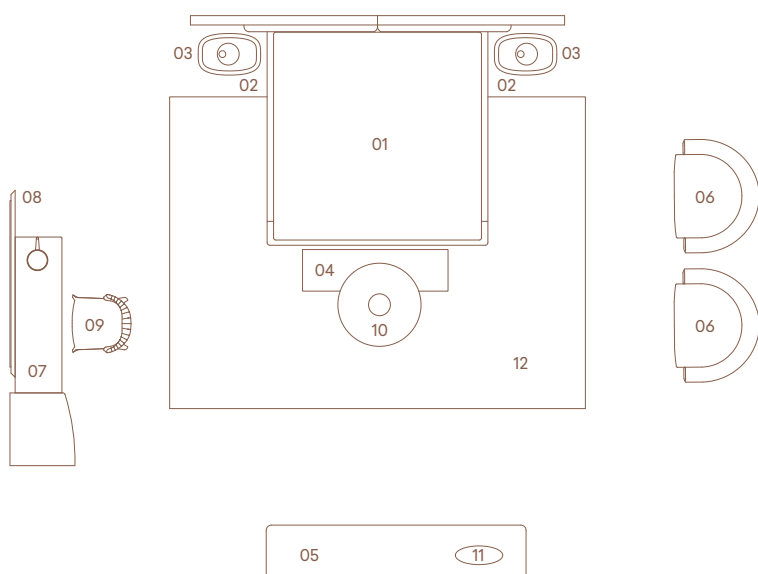

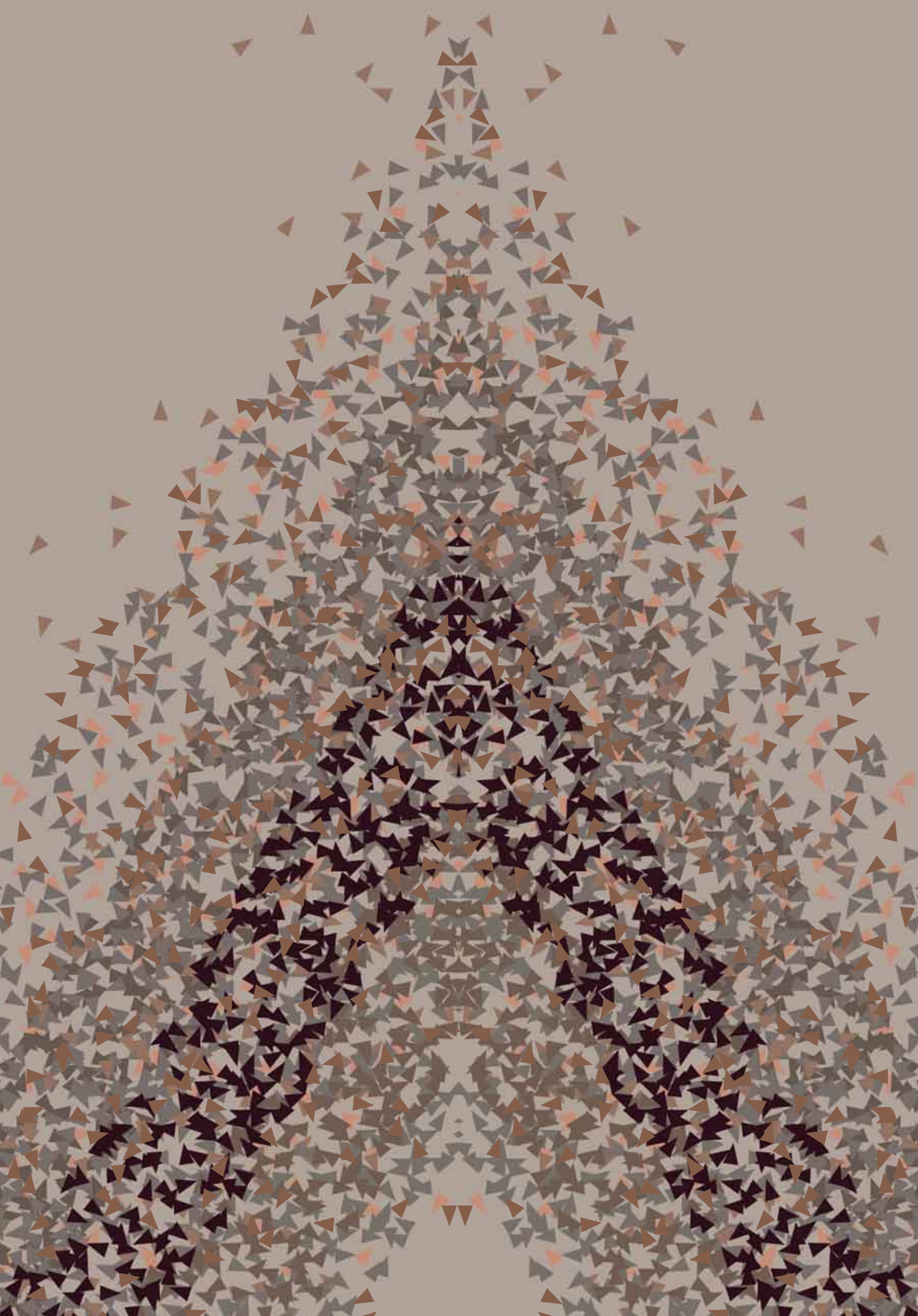



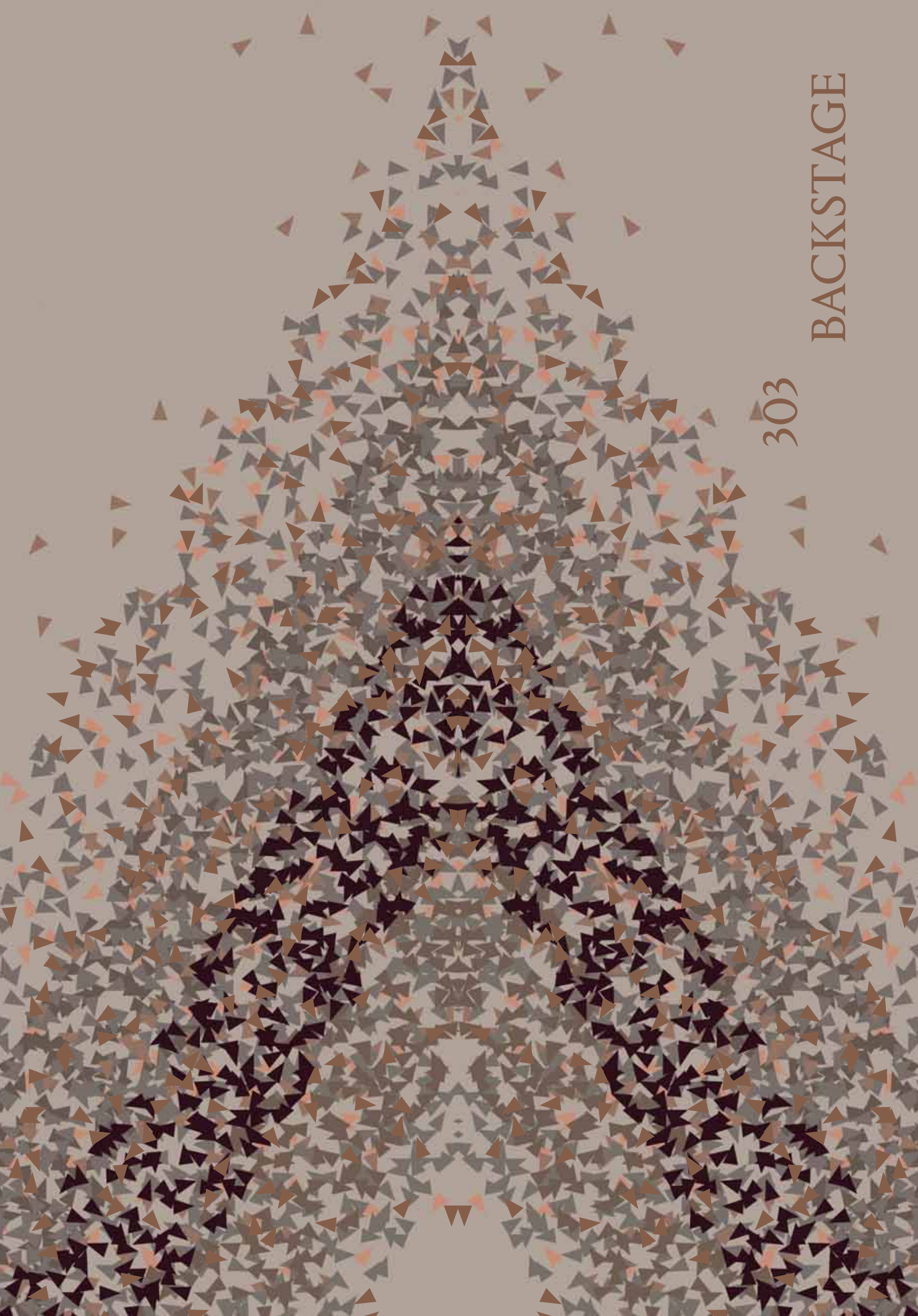

303

BACKSTAGE



**BACKSTAGE**  
Divano - Sofa

**BANNER**  
Consolle - Console

**MEZZARO GLAM**  
Glam plaid

**CLAN**  
Plaid



**BACKSTAGE**  
Divano componibile - *Modular sofa*

**BANNER**  
Tavolo basso - *Low table*

**PARKER**  
Mobile con ante - *Cabinet*

**REMY-17**  
Tappeto - *Carpet*













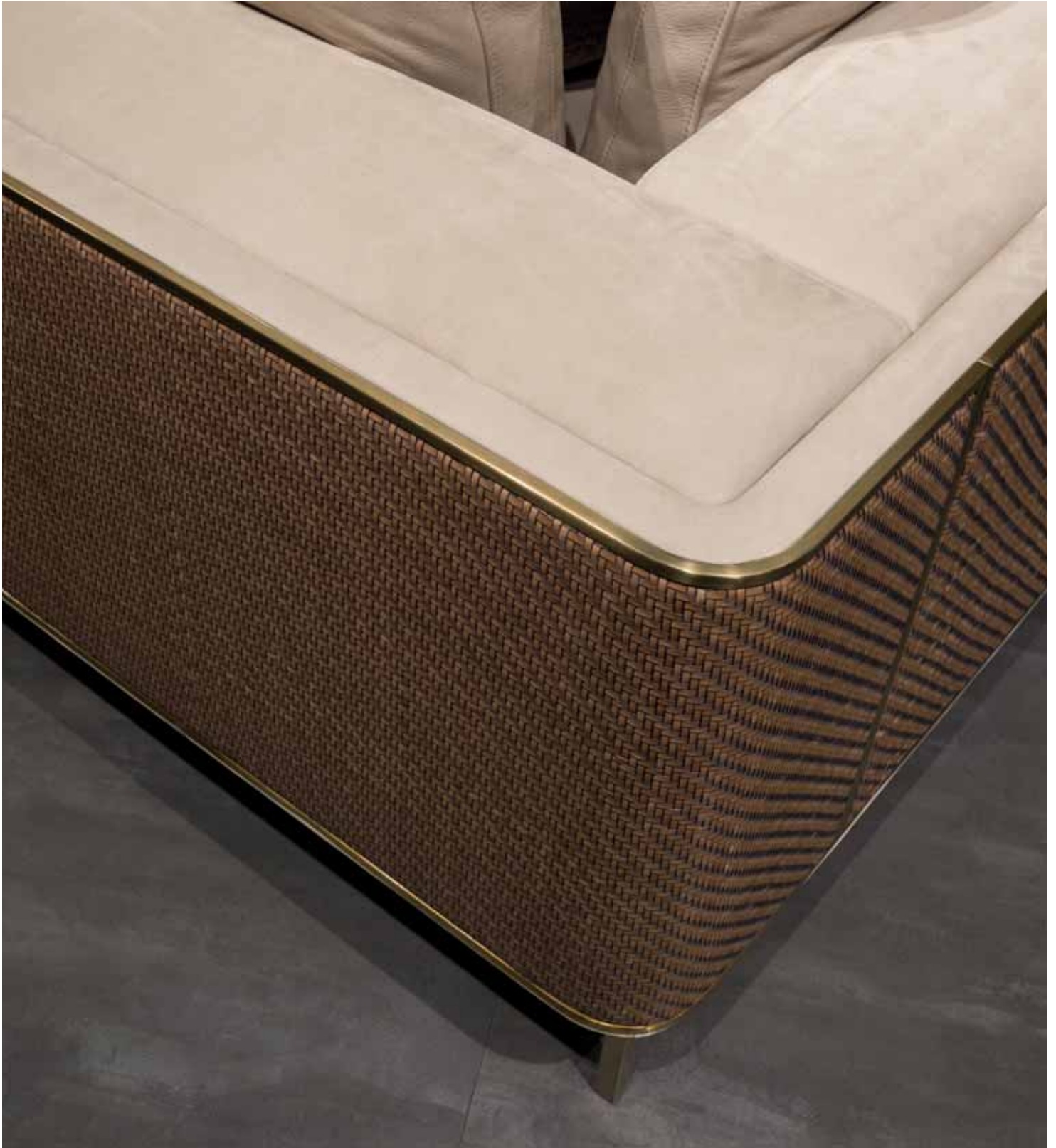

**BEETLE / A-B-C-D-E-F**  
Art gallery

**BACKSTAGE**  
Divano componibile - *Modular sofa*





**BANNER**  
Consolle - Console



**BACKSTAGE**  
Divano - Sofa

**MEZZARO GLAM**  
Glam plaid







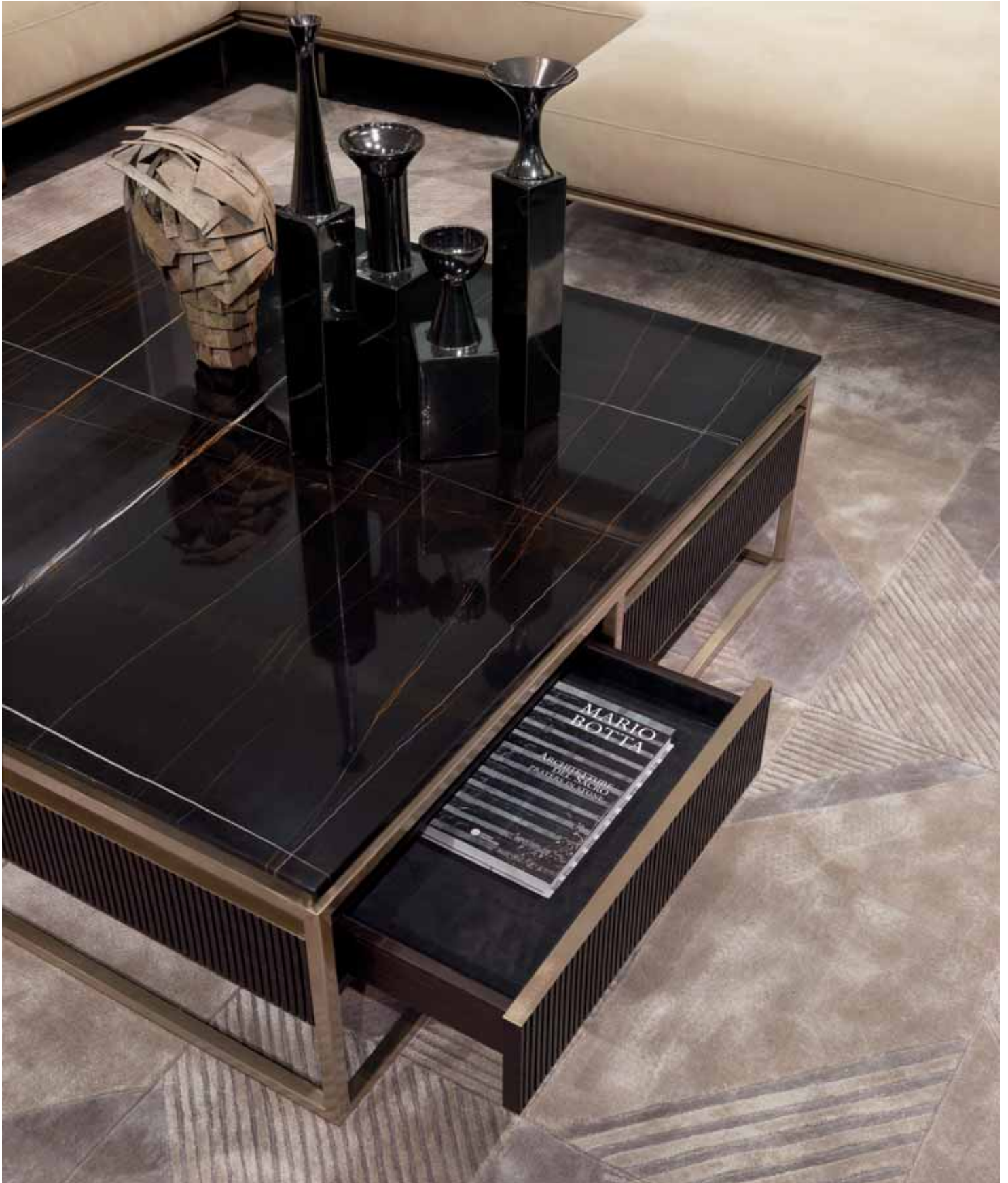

**BANNER**  
Tavolo basso - *Low table*

**PARKER**  
Mobile con ante - *Cabinet*

**BAMBÙ**  
Art gallery







**ETHAN**  
Lampadario - *Chandelier*

**CLAN**  
Plaid



**ETHAN**

Applique - Wall lamp

**PARKER**

Mobile con ante - Cabinet



OMEGA  
Lampada da tavolo - *Table lamp*





**POLIDORO**  
Specchio - *Mirror*

**BANNER**  
Consolle - *Console*









**BANNER**  
Consolle - Console

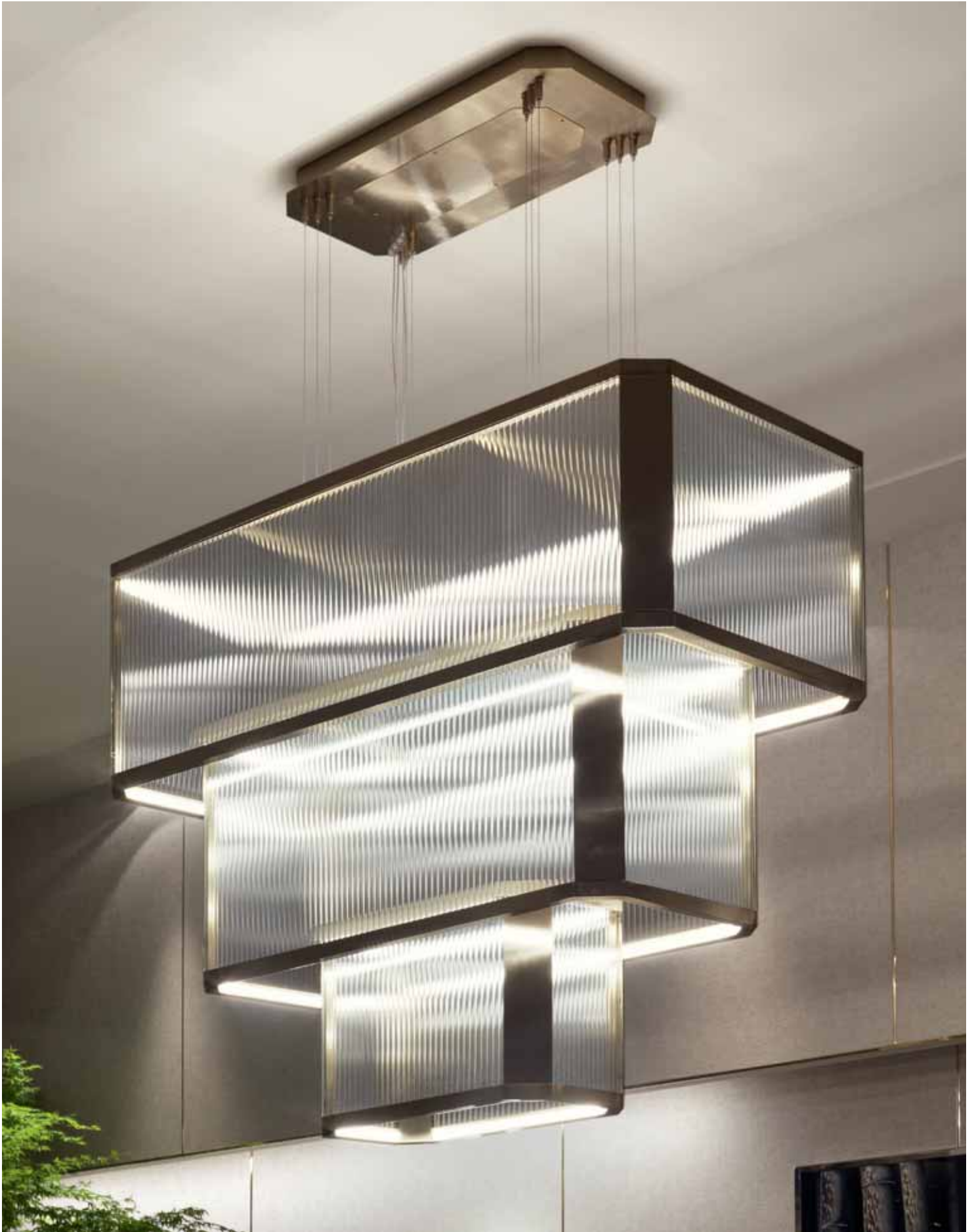

**ETHAN**  
Lampadario - Chandelier

## 01. BACKSTAGE

Divano cm 290x106 H.68. Scocca esterna in pelle intrecciata Tepic 24280/90 Cioccolato, rivestimento cuscini in tessuto Essential 24154/28 Bruno, filetti pelle Soft Leather 1194 Segale. Struttura di base e profilature acciaio oro satinato.

*Sofa cm 290x106 H.68. External structure in leather Tepic 24280/90 Cioccolato, cushions in fabric Essential 24154/28 Bruno with pipings in Soft Leather 1194 Segale. Base and profiles in gold satinized steel.*

## MEZZARO GLAM

Glam plaid, cm 155x168. Grigio scuro e marrone.

*Glam plaid, cm 155x168. Dark grey and brown.*

## 02. BACKSTAGE

Divano componibile: una chaise longue destra cm 112x160 H.65 (BSDR24), un elemento laterale sinistro cm 225x106 H.65 (BSLL19), un elemento singolo con schienale cm 87x106 H.65 (BSCW2), un elemento doppio senza schienale cm 172x106 H.40 (BSCWH10), un bracciolo/tavolino cm 50x106 H.50 (BSBR1). Struttura di base e profilature acciaio oro satinato. Scocca esterna in pelle intrecciata Tepic 24280/08 Camoscio, cuscinatura pelle Levante 24278/03 Avorio. Cuscino volante cm 40x40 in tessuto Loreley 24284/25 Biscotto, cuscino volante cm 55x55 in Pacos 24288/006 Nocciola con filetti in pelle Soft Leather 1194 Segale.

*Sectional sofa: one right chaise longue cm 112x160 H.65 (BSDR24), one left side element cm 225x106 H.65 (BSLL19), one single element with back cm 87x106 H.65 (BSCW2), one double element without back cm 172x106 H.40 (BSCWH10), one arm/table cm 50x106 H.50 (BSBR1). Base structure and steel profiles in gold satinized steel. External structure in leather Tepic 24280/08 Camoscio, cushions in leather Levante 24278/03 Avorio. Loose cushion cm 40x40 in fabric Loreley 24284/25 Biscotto, loose cushion cm 45x45 in fabric Loreley 24284/25 Biscotto, loose cushion cm 55x55 in fabric Pacos 24288/006 Nocciola with pipings in Soft Leather 1194 Segale.*

## CLAN

Plaid, cm 240x150.

## 03. BANNER

Consolle cm 171x35 H.65. Struttura di base e profilature acciaio oro satinato. Top in marmo Arabescato Orobico Grigio. Cassetti in legno massello scanalato finitura B.181 Fiammato Sabbia opaco. Ripiano portariviste cristallo fumè.

*Console cm 171x35 H.65. Base structure and steel profiles in gold satinized steel. Top in marble Arabescato Orobico Grigio. Drawers in grooved solid wood B.181 Fiammato Sabbia mat finishing. Low shelf in smoked glass.*

## 04. BANNER

Consolle cm 180x40 H.95. Struttura di base e profilature acciaio oro satinato. Top in marmo Arabescato Orobico Grigio. Cassetti in legno massello scanalato finitura B.181 Fiammato Sabbia opaco. Ripiano portariviste cristallo fumè.

*Console cm 180x40 H.95. Base structure and steel profiles in gold satinized steel. Top in marble Arabescato Orobico Grigio. Drawers in grooved solid wood B.181 Fiammato Sabbia mat finishing. Low shelf in smoked glass.*

## 05. BANNER

Tavolo basso cm 120x120 H.38. Struttura di base e profilature acciaio oro satinato. Top in marmo Arabescato Orobico Grigio. Cassetti in legno massello scanalato finitura B.181 Fiammato Sabbia opaco.

*Low table cm 120x120 H.38. Base structure and steel profiles in gold satinized steel. Top in marble Arabescato Orobico Grigio. Drawers in grooved solid wood B.181 Fiammato Sabbia mat finishing.*

## 06. PARKER

Mobile basso ad ante e 2 cassetti cm 250x50 H.74. Struttura in essenza B181 opaco. Ante in legno massello scolpito in bassorilievo con disegno a rombi finitura B.181 Fiammato Sabbia opaco. Top in marmo Arabescato Orobico Grigio, struttura di base e profilature acciaio oro satinato.

*Low cabinet with doors and 2 drawers cm 250x50 H.74. Main structure in veneer B181 Fiammato Sabbia mat finishing. Doors in carved bas-relief solid wood with diamond pattern in B181 Fiammato Sabbia, mat finishing. Top in marble Arabescato Orobico Grigio, base and profiles in gold satinized steel.*

## 07. OMEGA

Lampada da tavolo cm Ø32 H.50. Diffusore in cristallo molato a mano ad alto spessore, struttura in acciaio oro satinato. Base in marmo Nero Marquina.

*Table lamp cm Ø32 H.50. Hand-ground crystal with high thickness, stem in gold satinized brass. Base in Nero Marquina marble.*

## 08. ETHAN

Lampadario rettangolare cm 120x60 H.80. Struttura in acciaio oro satinato. Vetri ondulati trasparenti. Illuminazione perimetrale a LED.

*Rectangular chandelier cm 120x60 H.80. Structure in gold satinized steel. Transparent corrugated glasses. Perimetral LED lighting.*

## 09. ETHAN

Applique cm 30x24 H.60. Struttura in acciaio finitura oro satinato. Vetri ondulati trasparenti. Illuminazione perimetrale a LED.

*Wall lamp cm 30x24 H.60. Structure in gold satinized steel. Transparent corrugated glasses. Perimetral LED lighting.*

## 10. POLIDORO

Specchiera cm 90x6 H.160. Cornice composita in marmo Arabescato Orobico Grigio e Sahara Noir. Struttura acciaio oro satinato.

*Mirror cm 90x6 H.160. Frame in marble Arabescato Orobico Grigio and Sahara Noir. Structure in gold satinized steel.*

## 11. REMY-17

Tappeto cm 400x300.

*Carpet cm 400x300.*

## 12. GIDEON

Vaso in vetro di Murano cm Ø22 H.22. Colore tabacco.

*Vase in Murano glass with ribs, cm Ø22 H.22 in colour tobacco.*

## 12. GIDEON

Vaso in vetro di Murano cm Ø19 H.44. Colore tabacco.

*Vase in Murano glass with ribs, cm Ø19 H.44 in colour tobacco.*

## ART GALLERY

Bambù cm 130x190, cornice cromata.

*Bambù cm 130x190, chromed steel frame.*

Beetle/A-B-C-D-E-F cm 60x80, cornice cromata.

*Beetle/A-B-C-D-E-F cm 60x80, chromed frame.*

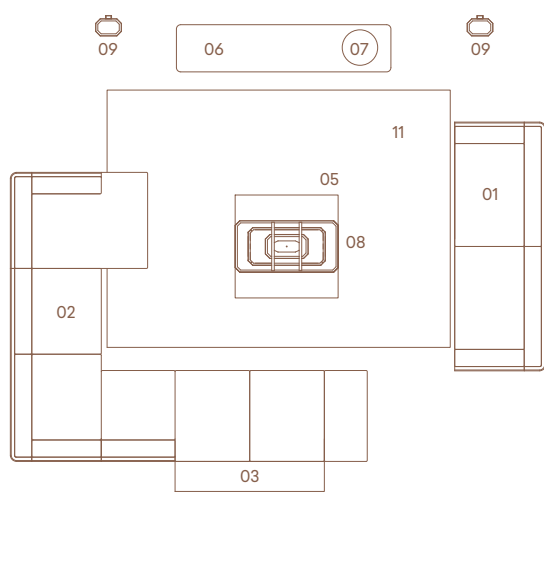

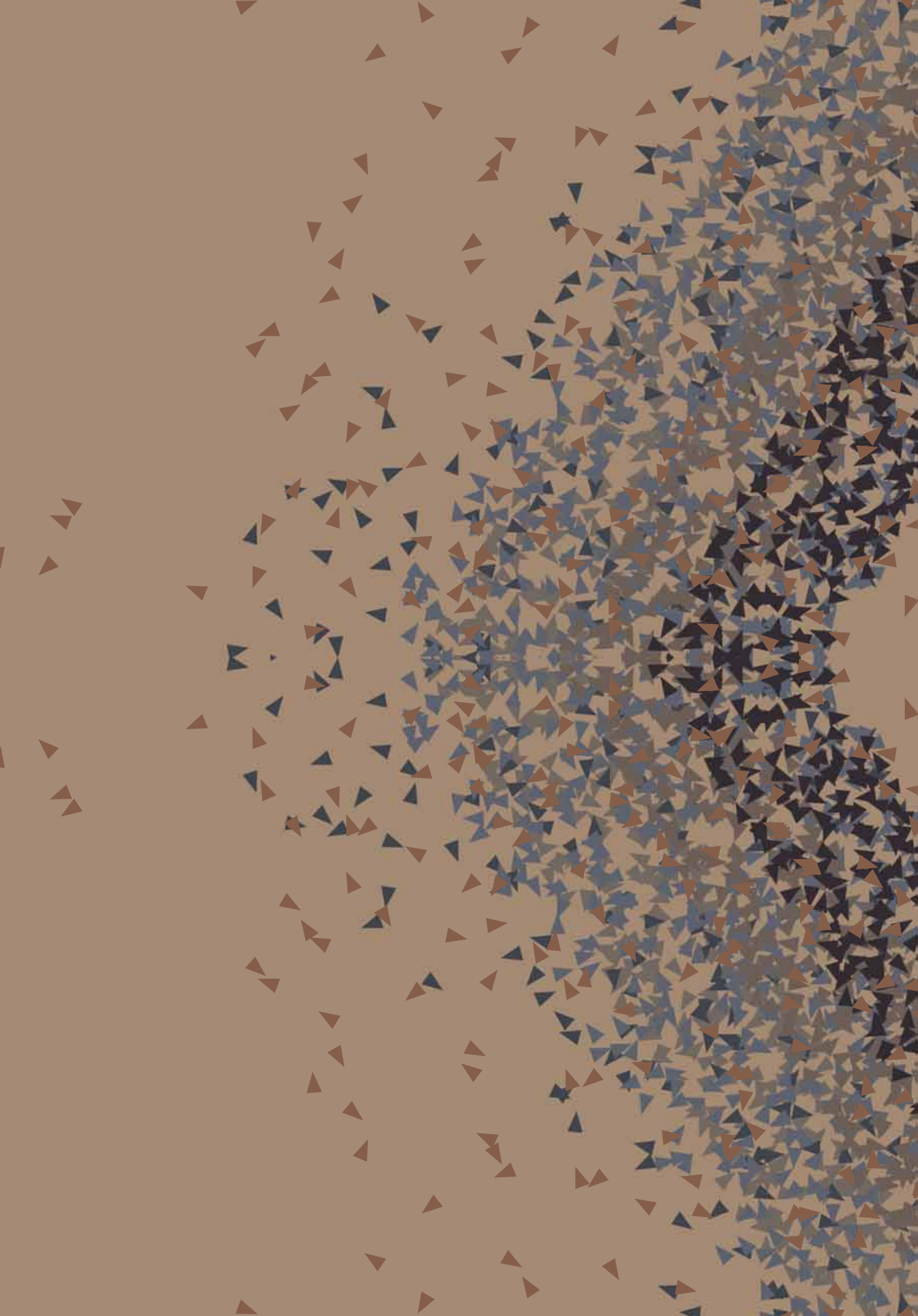

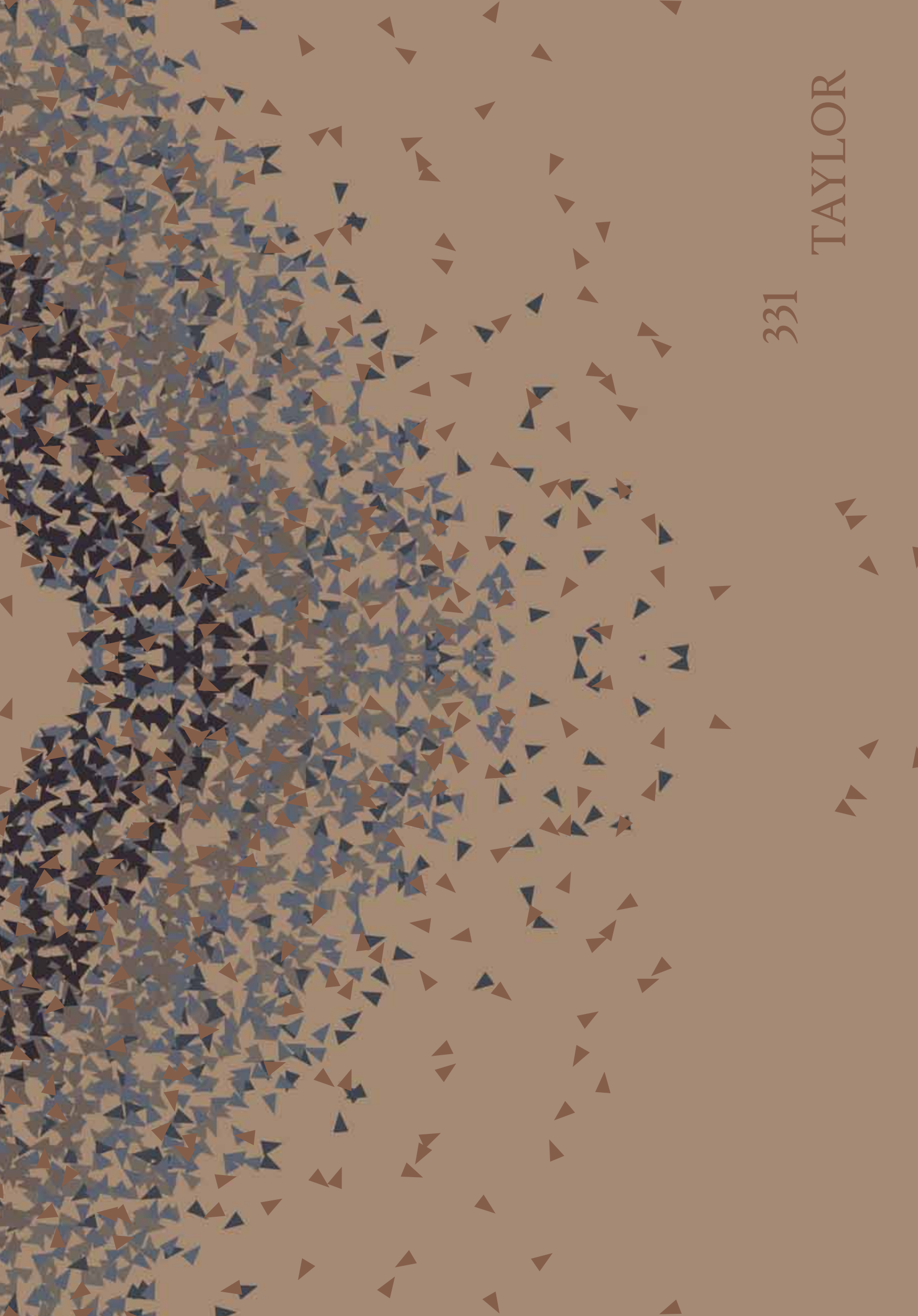

331

TAYLOR











**TAYLOR**  
Divano componibile - *Modular sofa*

**AGORA'V**  
Tavolo basso - *Shaped table*



**AGORÀ/V**  
Tavolo basso - *Shaped table*

**MIKA**  
Poltroncina - *Armchair*





TAYLOR  
Divano - Sofa





TAYLOR  
Divano - Sofa







### 01. TAYLOR DUAL

Divano componibile: un elemento laterale destro cm 220x110 H.67 in Empire 24179/01 perla, una chaise longue sinistra cm 160x140 H.67 in Lorooley 24284/07 Bistrò. Zoccolo in acciaio champagne satinato.  
Cuscini volanti cm 40x40. Rivestimento in Lorooley 24284/07 bistrò.  
Cuscino volante a saponetta cm 30x30. Rivestimento in pelle intrecciata Mandala 24281/90 Taupe e filetti Nabuk Maestrale 24127/3405 Tartufo.

*Sectional sofa: one right lateral element cm 220x110 H.67 in Empire 24179/01 perla, one left chaise longue cm 160x140 H.67 in Lorooley 24284/07 Bistrò. Base in champagne satinized steel.*

*Loose cushions cm 40x40. Upholstery in Lorooley 24284/07 bistrò.*

*Loose cushion with pipings, cm 30x30. Upholstery in interwoven leather Mandala 24281/90 Taupe and pipings in Nabuk Maestrale 24127/3405 Tartufo.*

### 02. TAYLOR STILL

Divano cm 295x110 H.67. Rivestimento in pelle Cordoba 24279/07 Pomice. Zoccolo in acciaio champagne satinato.  
Cuscini volanti cm 40x40. Rivestimento in Lorooley 24284/07 bistrò.

*Sofa cm 295x110 H.67. Upholstery in leather Cordoba 24279/07 Pomice. Base in champagne satinized steel.*

*Loose cushions cm 40x40. Upholstery in Lorooley 24284/07 bistrò.*

### 03. AGORÀ/V

Tavolino cm 135x135 H.37. Struttura in essenza B.182 con inserti in ottone. Base in acciaio champagne satinato.

*Low table 135x135 cm H.37. Structure in veneered wood B.182 with brass inserts. Base in champagne satinized steel.*

### 04. MIKA

Poltroncina cm 94x85 H.71. Rivestimento in Molveno 24298/51 Blu notte. Base girevole in acciaio champagne satinato.

*Armchair cm 94x85 H.71. Upholstery in Molveno 24298/51 Blu notte. Swivel base in satinized champagne finishing.*

### 05. FLOYD

Piantana cm Ø35 H.160. Paralume in vetro soffiato effetto tartaruga, base e stelo in acciaio champagne satinato.

*Floor lamp cm Ø35 H.160. Lampshade in blown glass with turtle effect. Base and stem in champagne satin steel.*

### 06. FLOYD

Piantana cm Ø35 H.180. Paralume in vetro soffiato effetto tartaruga, base e stelo in acciaio champagne satinato.

*Floor lamp cm Ø35 H.180. Lampshade in blown glass with turtle effect. Base and stem in champagne satin steel.*

### 07. GAYNOR

Libreria componibile cm 340x42 H.250. Spalle in essenza A.721 lucido. Schienali, ripiani, ante e frontali cassetti in pelle Taras 24296/25 Seppia. Ante in cristallo temperato fumè con maniglia in ottone champagne satinato. Interni laccati Ral 7037 opaco. Profili e base in acciaio champagne satinato.

*Bookshelf cm 340x42 H.250. Sides in glossy veneered wood A.721. Back, shelves, doors and front drawers in leather Taras 24296/25 Seppia. Doors in smoked tempered glass with knob in champagne satinized brass. Interiors lacquered Ral 7037, mat finishing. Profiles and base in champagne satinized steel.*

### 08. TAGORA

Tappeto cm 400x300.

*Carpet cm 400x300.*

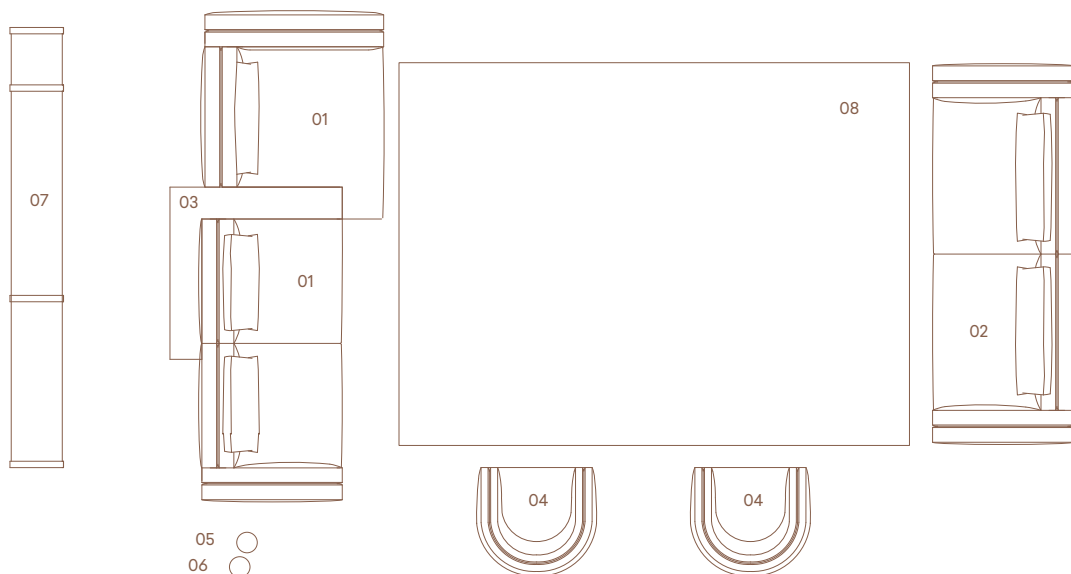





# AGORÀ

## Tavolo basso Coffee table

Design  
Giuseppe Viganò

Tavolo basso in legno laccato oppure rivestito in essenza intarsiata con profili decorativi in ottone o alluminio sp.5 mm. Base in legno, rivestita in acciaio inox satinato. Le diverse forme consentono innesti e accostamenti su misura con gli elementi componibili della serie Taylor. Le parti in legno sono disponibili nelle finiture selezione essenze, le parti in metallo sono disponibili nella selezione finiture metalliche satiniate.

Wooden coffee table lacquered or veneered and inlaid with decorative profiles in brass or aluminium, 5 mm thick. Wooden base, covered in satin stainless steel. The different shapes allow grafts and combinations to measure with the modular elements of the Taylor series. Wooden parts available in the veneer finishings selection, metal parts available in the satinized metal finishing selection.

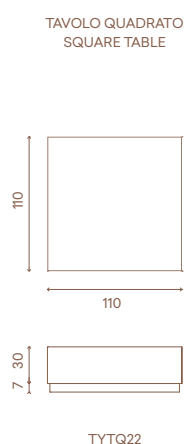
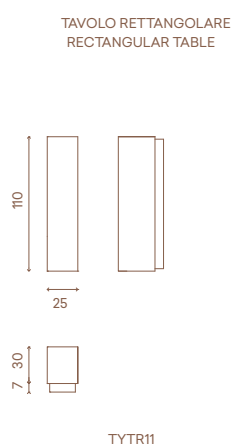
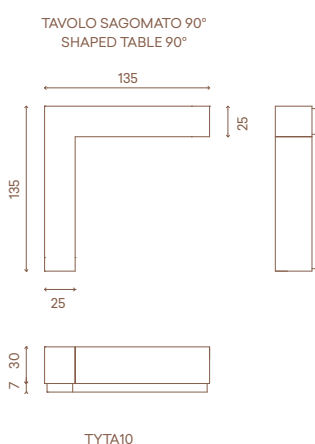
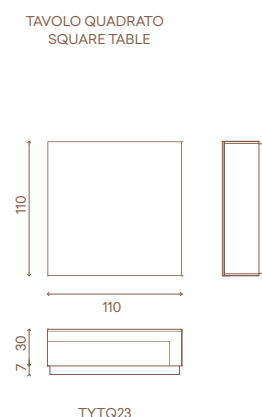
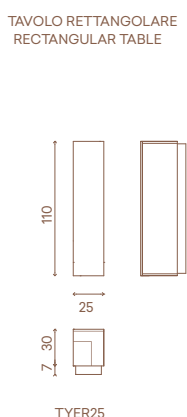
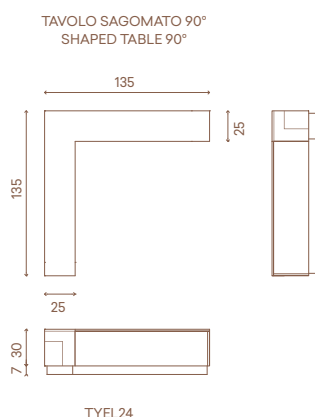

# AKIRA

## Applique singola Single wall lamp

Design  
Alessandro La Spada

Applique a una luce con struttura a stelo in ottone lucidato. Portalampada in ottone tornito e luce G9 da 40W con diffusore in vetro satinato. Paralume concavo "a ventaglio" in tessuto stampato floreale con diffusore interno in tessuto moiré. I paralumi sono disponibili anche in tessuto a campionario. Le parti in metallo sono disponibili nella selezione finiture metalliche.

Single light wall lamp with polished brass stem structure. Lampholder in turned brass and G9 40W bulb with frosted glass diffuser. Concave "fan-shaped" lampshades in printed floral fabric with internal moiré fabric diffuser. The lampshades are also available in fabric according to sample fabric. Metal parts available in the metal finishing selection.

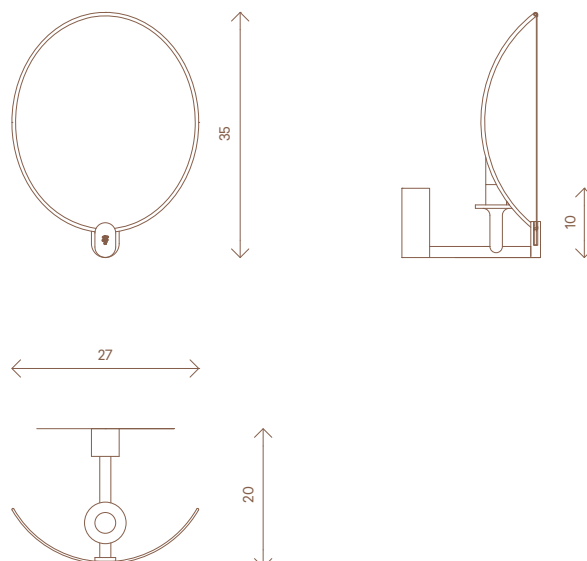

# AKIRA

Applique  
Wall lamp

Design  
Alessandro La Spada

Applique a 4 luci con struttura in ottone lucidato, i bracci curvati sono fissati al fusto centrale tramite elementi in ottone massiccio. Portalampade in ottone tornito e luci G9 da 40W con diffusore in vetro satinato. Paralumi concavi "a ventaglio" in tessuto stampato floreale con diffusore interno in tessuto moiré. I paralumi sono disponibili anche in tessuto a campionario. Le parti in metallo sono disponibili nella selezione finiture metalliche.

*4 lights wall lamp with polished brass structure, the curved arms are fixed to the central stem by solid brass elements. Lampholders in turned brass and G9 40W bulbs with frosted glass diffuser. Concave "fan-shaped" lampshades in printed floral fabric with internal moiré fabric diffuser. The lampshades are also available in fabric according to sample fabric. Metal parts available in the metal finishing selection.*

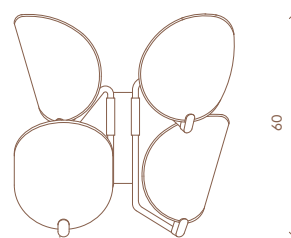

60

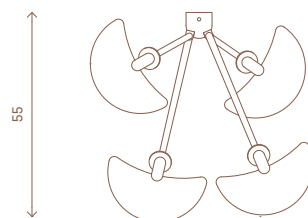

65

# AKIRA

Lampadario  
Chandelier

Design  
Alessandro La Spada

Lampadario a 12 oppure 16 luci con struttura in ottone lucidato, i bracci curvati sono fissati al fusto centrale tramite elementi in ottone massiccio. Portalampade in ottone tornito e luci G9 da 40W con diffusore in vetro satinato. Paralumi concavi "a ventaglio" in tessuto stampato floreale con diffusore interno in tessuto moiré. I paralumi sono disponibili anche in tessuto a campionario. Le parti in metallo sono disponibili nella selezione finiture metalliche.

*12 or 16 lights chandelier with polished brass structure, the curved arms are fixed to the central stem by solid brass elements. Lampholders in turned brass and G9 40W bulbs with frosted glass diffuser. Concave "fan-shaped" lampshades in printed floral fabric with internal moiré fabric diffuser. The lampshades are also available in fabric according to sample fabric. Metal parts available in the metal finishing selection.*

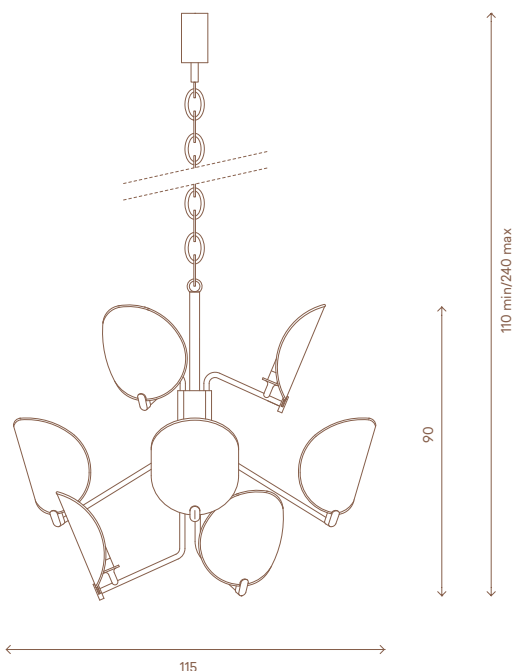

115

90

110 min/240 max

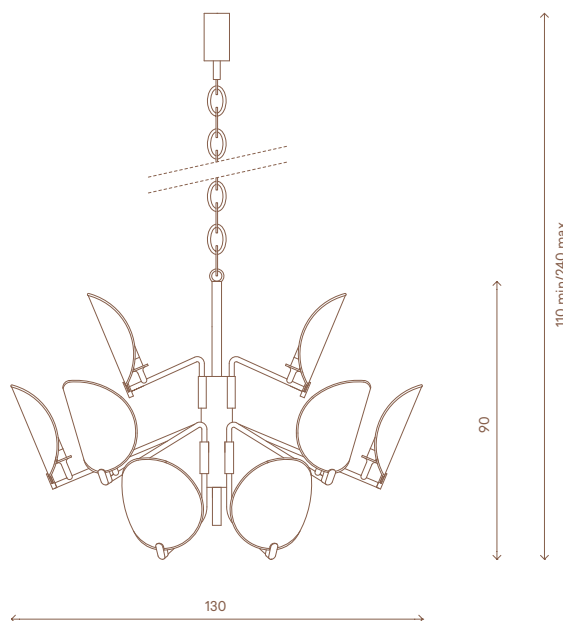

130

90

110 min/240 max

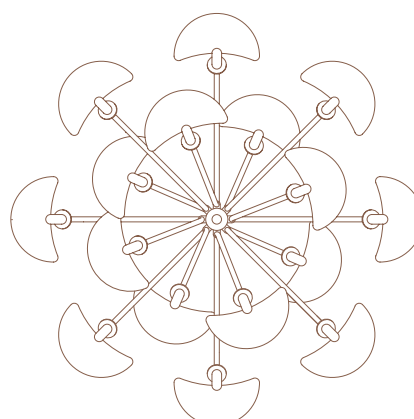
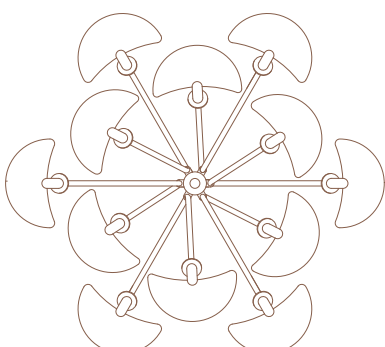

# AKIRA

Lampada da tavolo  
Table lamp

Design  
Alessandro La Spada

Lampada da tavolo a una luce con base di appoggio in ottone lucidato, con paralume verticale concavo "a ventaglio" in tessuto stampato floreale oppure a campionario, con diffusore interno in tessuto moiré. Paralume posteriore anti abbagliante in acciaio inox microforato con trama grafica floreale. Portalampana in ottone tornito e luce G9 da 40W con diffusore in vetro. Le parti in metallo sono disponibili nella selezione finiture metalliche.

One light table lamp with polished brass base, with concave fan shaped vertical lampshade in printed floral fabric (available also according to sample fabric), with internal moiré fabric diffuser. Anti-glare rear lampshade in micro-perforated stainless steel with floral graphic texture. Lampholder in turned brass and G9 40W bulb with glass diffuser. Metal parts available in the metal finishing selection.

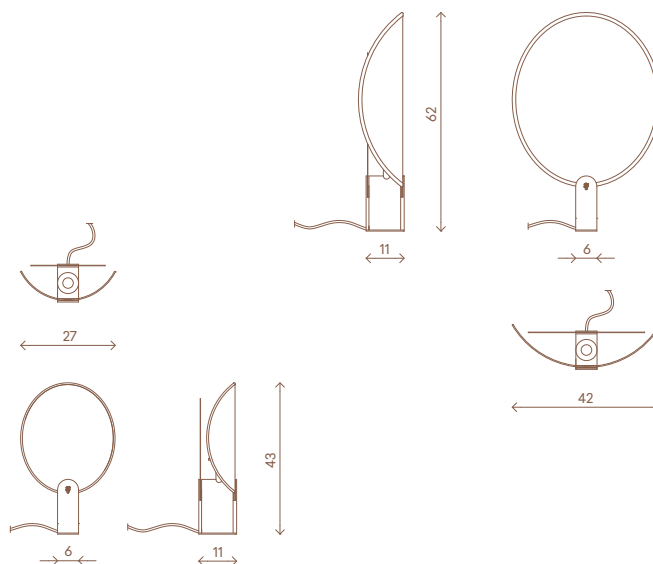

# ANASTASIA

Poltrona  
Armchair

Design  
Roberto Tapinassi – Maurizio Manzoni

Poltrona interamente in cuoio spessore 3 mm con inserti spalliera intagliati con motivo gessato. Struttura interna in metallo.

Armchair entirely in 3 mm thick leather with carved espalier inserts with a pinstripe pattern. Internal metal structure.

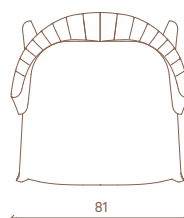
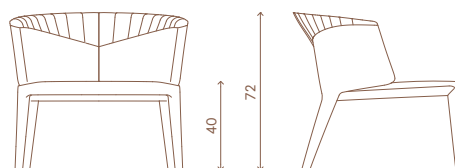
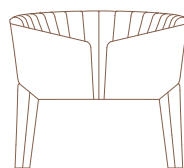

# ANASTASIA

Poltroncina  
Armchair

Design  
Roberto Tapinassi – Maurizio Manzoni

Poltroncina interamente in cuoio spessore 3 mm con inserti spalliera intagliati con motivo gessato. Struttura interna in metallo.

Armchair entirely in 3 mm thick leather with carved espalier inserts with a pinstripe pattern. Internal metal structure.

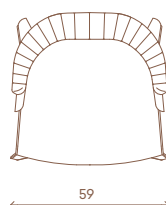
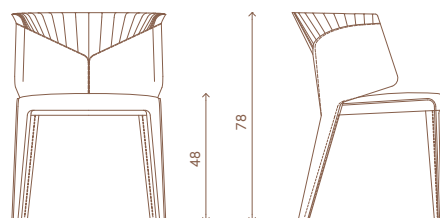
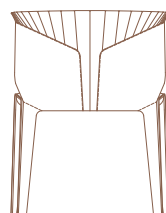

# ANASTASIA

Sedia  
Chair

Design  
Roberto Tapinassi – Maurizio Manzoni

Sedia interamente in cuoio spessore 3 mm con inserti spalliera intagliati con motivo gessato. Struttura interna in metallo.

*Chair entirely in 3 mm thick leather with carved espalier inserts with a pinstripe pattern. Internal metal structure.*

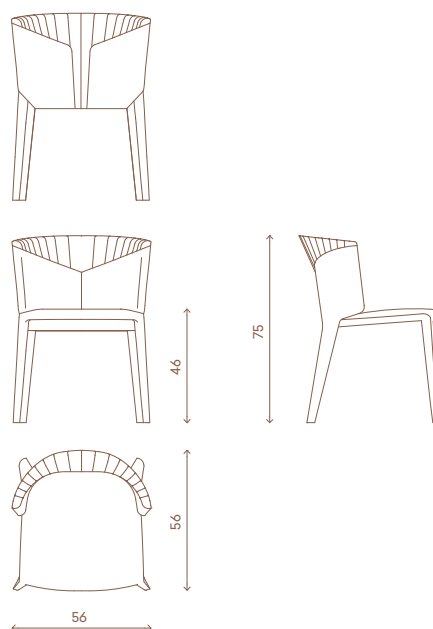

# ANTHAR

Dormeuse  
Dormeuse

Design  
Roberto Lazzeroni

Dormeuse tappezzata in pelle o tessuto. Struttura in multistrati e massello di legno con schienale curvo sospeso, sedile molleggiato con cinghie elastiche e imbottitura in poliuretano a diverse densità, memory foam® e piuma d'oca. Cuscini volanti in piuma. Base sagomata in legno massello verniciato nero lucido.

*Dormeuse upholstered in leather or fabric. Structure in plywood and solid wood with curved backrest, seat suspension with elastic straps and polyurethane padding in different densities, memory foam® and goose down. Loose cushions in feathers. Shaped base in solid black lacquered solid wood.*

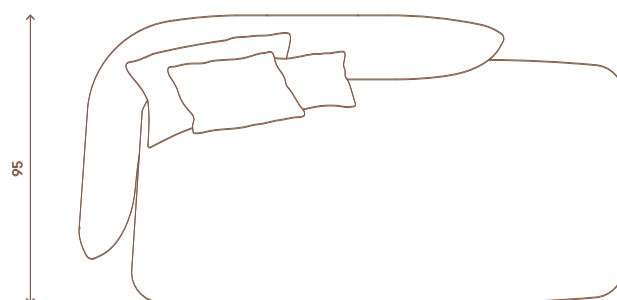
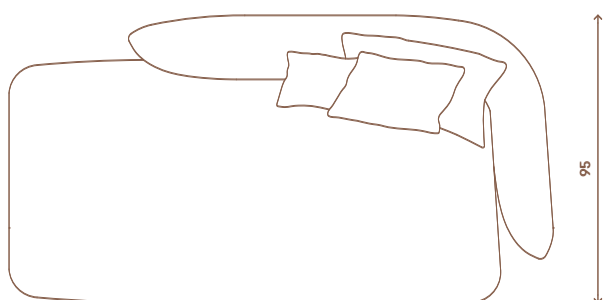
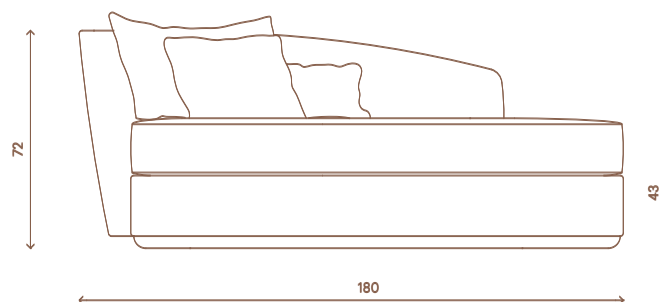
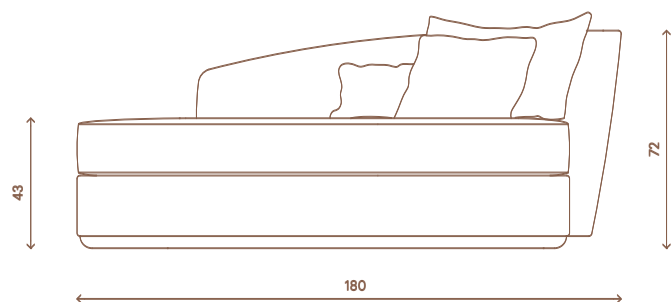

DORMEUSE SX  
DORMEUSE L

DORMEUSE DX  
DORMEUSE R

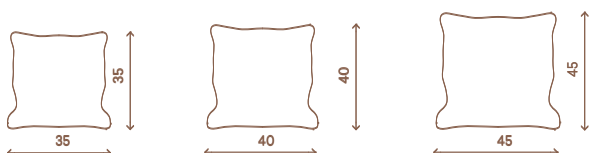

CUSCINI VOLANTI  
LOOSE CUSHIONS

# ANTHAR

## Divano e Pouf Sofa and Pouffe

Design  
Roberto Lazzeroni

Divano tappezzato in pelle o tessuto. Struttura in multistrati e massello di legno con schienale curvo sospeso, sedile molleggiato con cinghie elastiche e imbottitura in poliuretano a diverse densità, memory foam® e piuma d'oca. Cuscini volanti in piuma. Base sagomata in legno massello verniciato nero lucido.

Pouf con struttura interna in legno, imbottitura in poliuretano a densità differenziate. Rivestimento in pelle o tessuto. Base sagomata in legno massello verniciato nero lucido.

*Upholstered sofa in leather or fabric. Structure in plywood and solid wood with curved backrest, seat suspension with elastic straps and polyurethane padding in different densities, memory foam® and goose down. Loose cushions in feathers. Shaped base in solid black lacquered solid wood.*  
*Pouffe with internal structure in wood, padded in polyurethane with different densities. Upholstery in leather or fabric. Shaped base in solid black lacquered solid wood.*

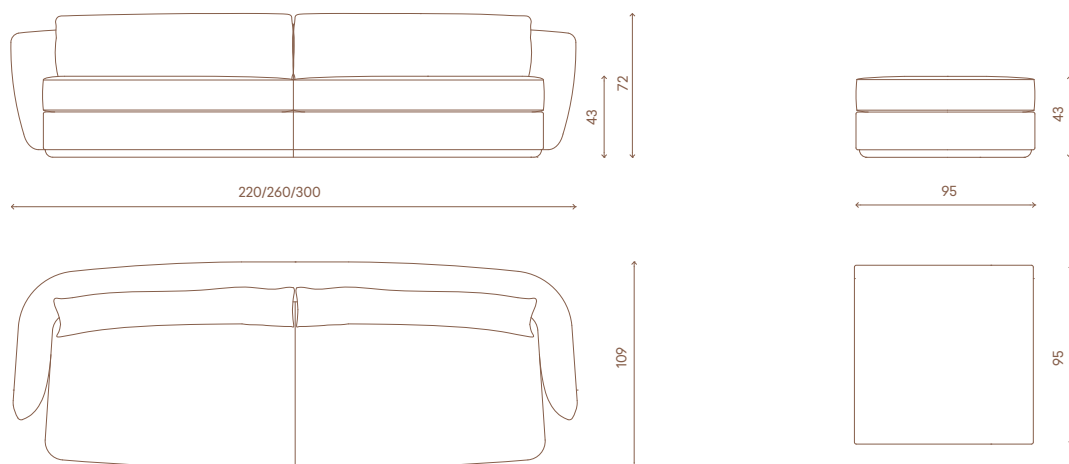

# ASTRA

## Lampada da tavolo Table lamp

Design  
Marco Piva

Lampada da tavolo in metallo cromato lucido e vetro soffiato, con paralume conico intagliato in bassorilievo a righe orizzontali, con veletta in vetro soffiato parzialmente satinato. Stelo conico con terminale in vetro soffiato. L'impianto si compone di 3 sorgenti luminose LED E14 da 6W a luce calda.

*Table lamp in polished chromed metal and blown glass, with conical lampshade carved in low-relief horizontal stripes, with partially satinized-blown glass. Conical stem with blown glass terminal. The system consists of three 6W E14 LED light sources with warm light.*

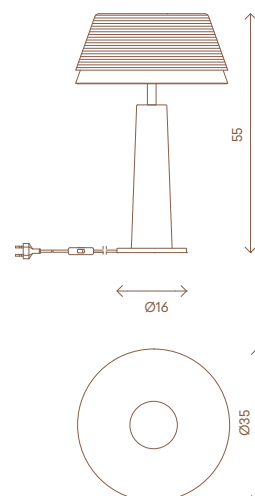

# ASTRID

## Sedia Chair

Design  
Alessandro La Spada

Sedia imbottita con scocca in legno curvato imbottita e rivestita in pelle o tessuto. Gambe in fusione di alluminio satinato disponibile nella selezione finiture metalliche. Lo schienale è disponibile anche nella versione "quilted" in pelle con ricamo con disegno foliage, leggermente imbottito.

*Padded chair with curved wood shell upholstered and covered in leather or fabric. Legs in aluminum cast available in the metal finishing selection. The back is also available in the "quilted" version in leather with embroidery with a slightly padded, foliage design.*

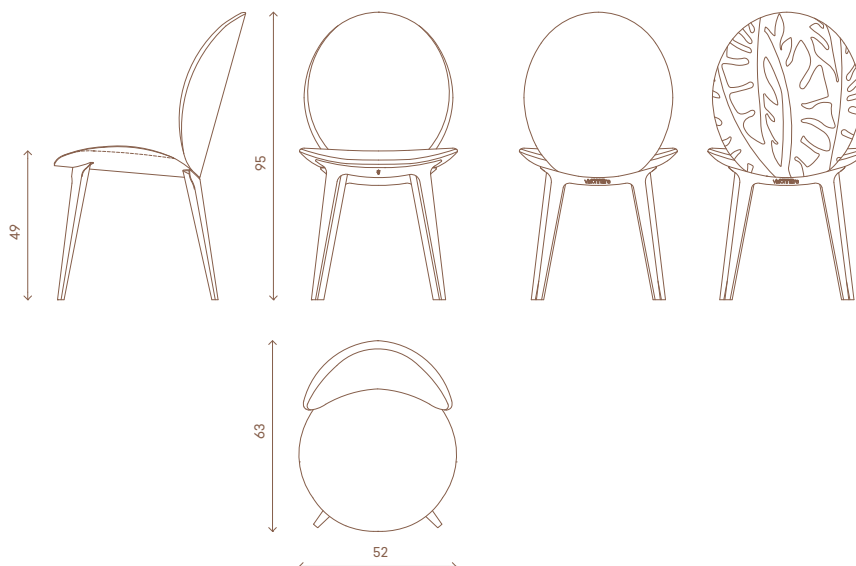



# ATREYU

Tavolino  
Small table

Design  
Mauro Lipparini

Struttura tubolare di acciaio inox satinato con top in marmo con profilo ribassato. Le parti in metallo, solo satinate, sono disponibili nella selezione finiture metalliche.

*Tubular structure in satinized stainless steel with low-profile marble top. Satinized metal parts available in the metal finishing selection.*

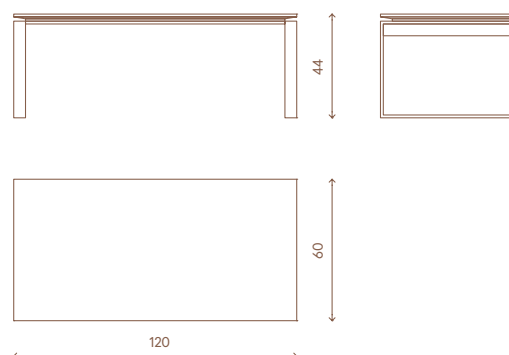

# AURORA

Consolle  
Console

Design  
Steve Leung

Consolle con tre cassetti in legno rivestita in lamiera di acciaio inox satinato, interni e schienale laccati opaco (colori RAL). Cassetti rivestiti in marmo con intarsi e cornice in acciaio inox, gambe in fusione di alluminio lucidata a specchio con puntali in alluminio satinato. Parti in metallo disponibili in finitura oro o bronzo oppure nickel nero.

*Wooden console with three drawers covered in brushed stainless steel, internal and back part in lacquered mat (RAL colours). Drawers covered in marble, framed and inlaid in stainless steel. The inlay design continues on the sides. Legs in polished aluminium cast with final tips in brushed aluminium. All metal details are available in gold, bronze or black nickel finishing.*

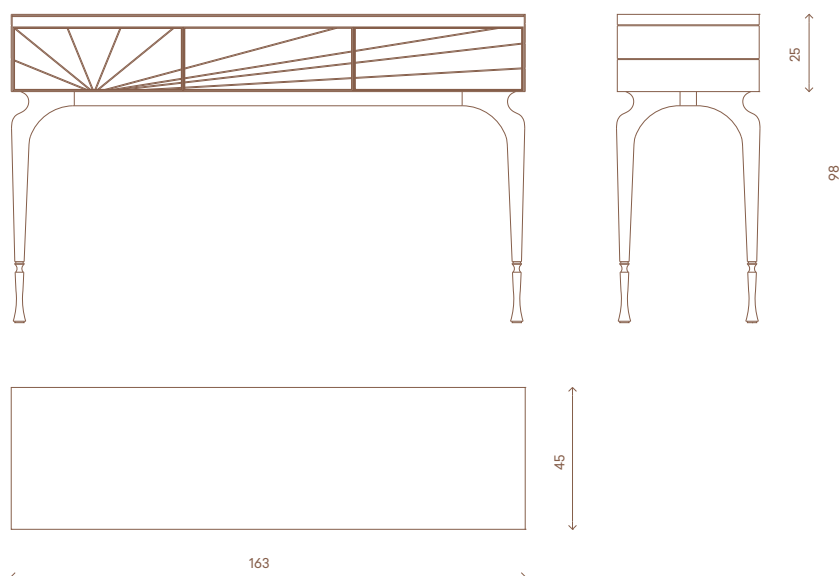

# AURYN

Tavolino  
Low table

Design  
Mauro Lipparini

Struttura in mdf rivestito in essenza laccata lucida con ripiani rivestiti in pelle. Le parti in legno sono disponibili nelle finiture selezione essenze.

*Structure in MDF covered in shiny lacquered veneered wood with shelves upholstered in leather. Wooden parts are available in the veneer selection.*

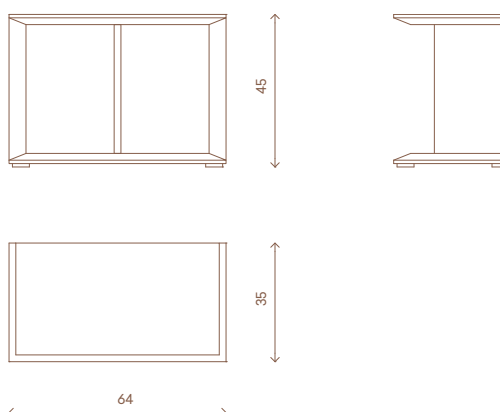

# AZIMUT

Consolle  
Console

Design  
Steve Leung

Consolle con due cassetti, struttura in multistrati di legno rivestita in pelle o laccata, gole in acciaio inox satinato, pannelli decorativi frontali in marmo oppure in pietra naturale a spacco vivo con inserti in acciaio inox lucido. Gambe in acciaio inox satinato. Le parti in acciaio sono disponibili satiniate nella selezione finiture metalliche.

*Console with 2 drawers, structure in plywood covered in leather or in lacquered wood, grooves and frames in satinized stainless steel, front decorative panels in marble or in natural cleft stone with inserts in shiny stainless steel. Legs in satinized stainless steel. Metal parts available in the satinized metal finishing selection.*

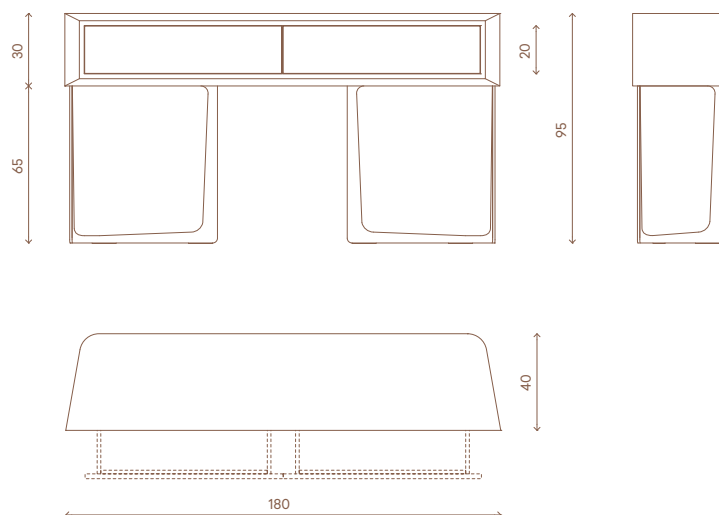

# AZIMUT

Madia  
High unit

Design  
Steve Leung

Struttura in multistrati di legno a quattro ante, due cassetti interni, rivestita in pelle o laccata, gole e cornici delle ante in acciaio inox satinato, pannelli decorativi frontali in marmo oppure in pietra naturale a spacco vivo con inserti in acciaio inox lucido. Gambe in acciaio inox satinato. Le parti in acciaio sono disponibili satiniate nella selezione finiture metalliche.

*Structure in plywood with 4 doors and 2 internal drawers, covered in leather or in lacquered wood, doors grooves and frames in satinized stainless steel, front decorative panels in marble or in natural cleft stone with inserts in shiny stainless steel. Legs in satinized stainless steel. Metal parts available in the satinized metal finishing selection.*

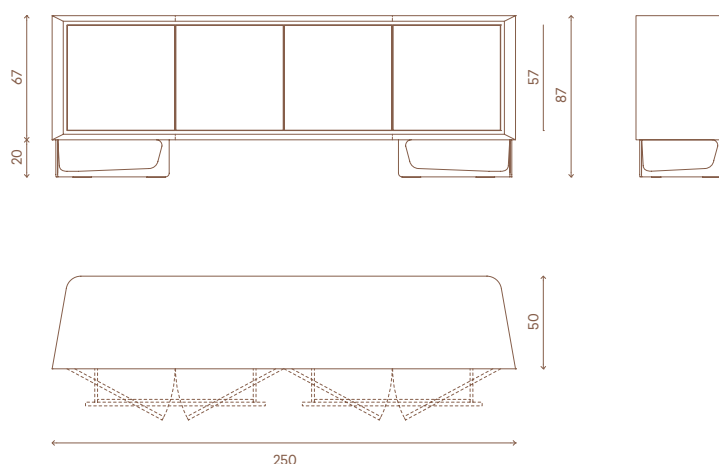

# BABYLON

Divano, elementi componibili  
Sofa, modular elements

Design  
Alessandro La Spada

Struttura interna in legno massello e multistrati con molleggio a cinghie elastiche, imbottitura in poliuretano espanso. Schienale e braccioli tappezzati esternamente con pannelli leggermente imbottiti a formare un motivo geometrico astratto e inserti in acciaio satinato con logo, piano superiore dei braccioli liscio, profilo perimetrale in acciaio inox satinato con clips marchiate Visionnaire. Rivestimento in pelle o tessuto. Cuscini di seduta in poliuretano, strato superiore in Memory Foam® e piuma d'oca. Cuscini volanti in piuma d'oca. Disponibile elemento tavolo basso con vano portariviste tappezzato e top in marmo. Le parti metalliche sono disponibili nella selezione finiture metalliche satiniate.

*Internal structure in solid wood and plywood with elastic strap springing system; padding in polyurethane foam. Backrest and armrests externally upholstered with slightly padded tiles, creating an abstract geometrical motive and inserts in satinized steel with logo; smooth upper surface of the armrests; perimetral profile in satinized stainless steel with clips with engraved Visionnaire logo. Upholstery in leather or fabric. Seat cushions in polyurethane, upper layer in Memory Foam® and goose feathers. Loose cushions in goose feathers. Optional element available: low table with upholstered magazine-holder shelf and top in marble. Metal parts available in the satinized metal finishing selection.*

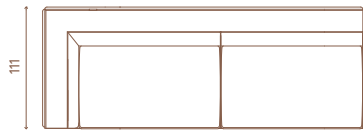
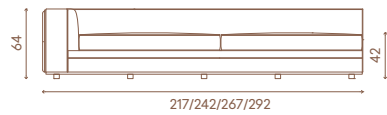
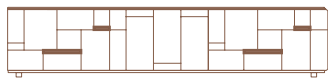
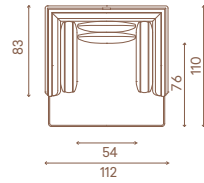
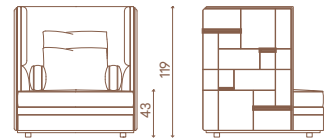
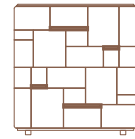
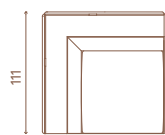
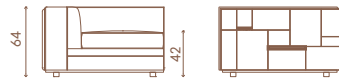
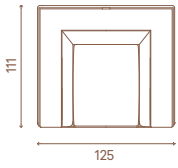
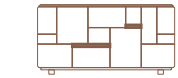
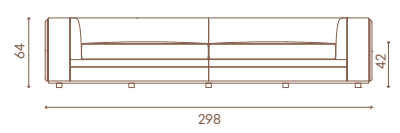
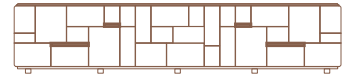
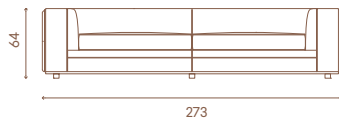
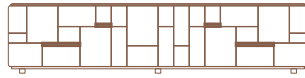
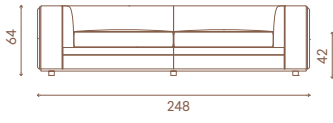
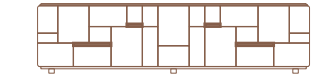
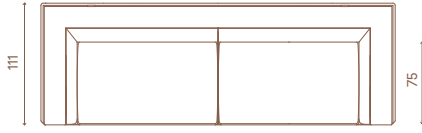
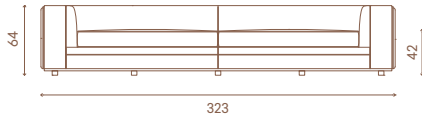
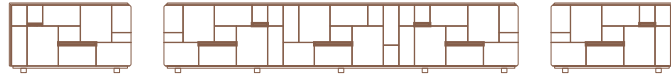

SX

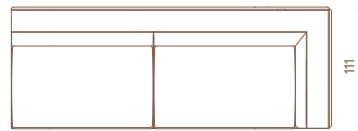
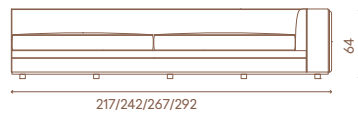
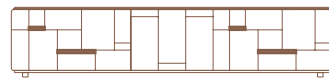

DX

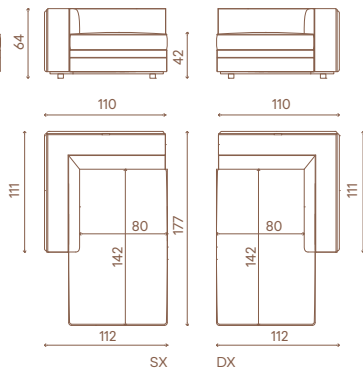
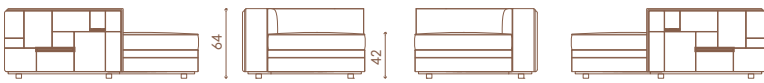

SX

DX

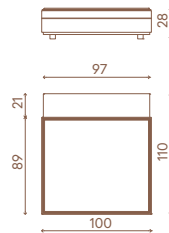

# BACKSTAGE

Divano, divano componibile  
Sofa, modular sofa

Design  
Fabio Bonfà

Divano tappezzato in pelle o tessuto, con base composta da un telaio in acciaio inox satinato e un pannello in legno e metallo rivestito in pelle o tessuto, dotato di cinghie elastiche per il molleggio dei sedili. Braccioli e schienali in legno bordati da un profilo in ottone sp.10x10 mm tappezzati con pelle, tessuto oppure pelle intrecciata imbottiti nella parte interna. Cuscini di seduta in poliuretano a diverse densità, memory foam® e piuma. Cuscini di schienale e interno bracciolo in poliuretano e piuma, cuscini volanti in piuma. Le parti metalliche sono disponibili nella selezione finiture metalliche satinato. Versione componibile disponibile con elementi centrali senza schienale abbinabili alla consolle Banner.

Sofa upholstered in leather or fabric, with base composed of a frame in satinized stainless steel and a panel in wood and metal covered in leather or fabric, equipped with elastic belts for the seats suspension. Armrests and backrests made of a wooden panel edged by a brass profile th.10x10 mm, and upholstered with leather, fabric or woven leather padded on the inside. Seat cushions in polyurethane with different densities, memory foam® and feather. Back and armrest cushions in polyurethane and feather, loose cushions in feather. Metal parts available in the satinized metal finishing selection. Modular sofa available with central elements without backrest that can be combined with the Banner console.

DIVANO  
SOFA

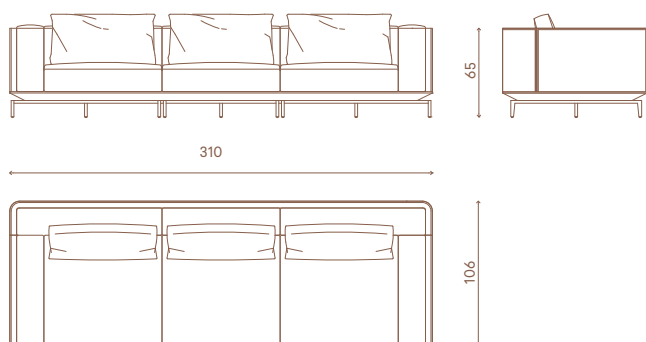

DIVANO  
SOFA

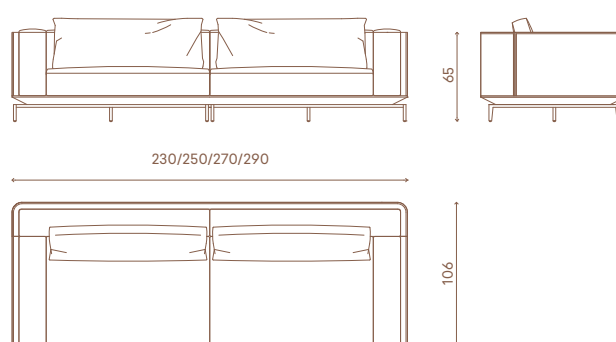

ELEMENTO LATERALE SX  
LATERAL ELEMENT L

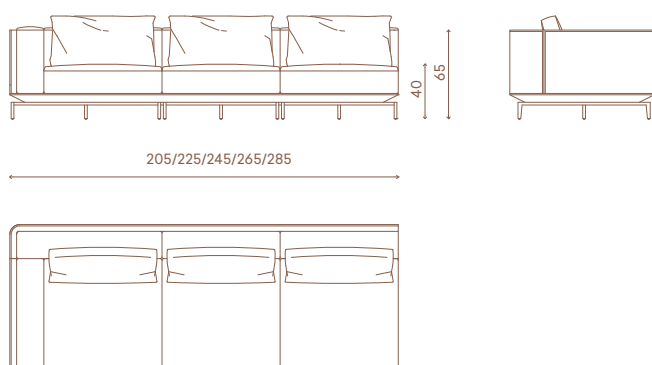

BSSL series

ELEMENTO LATERALE SX  
LATERAL ELEMENT R

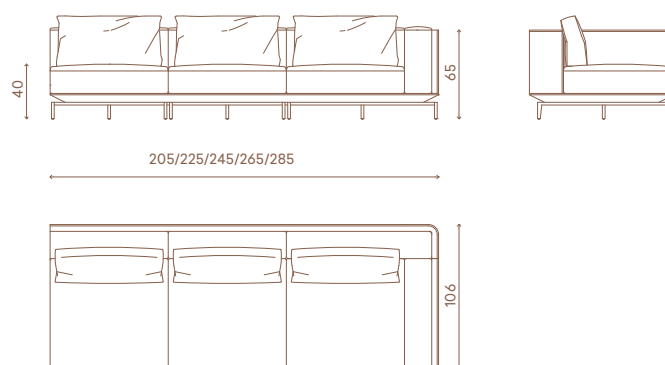

BSLR series

ELEMENTO CENTRALE  
CENTRAL ELEMENT

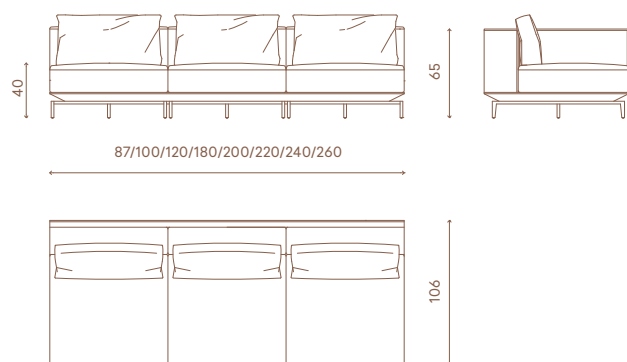

BSCW series

ELEMENTO CENTRALE SENZA SCHIENALE  
CENTRAL ELEMENT WITHOUT BACK

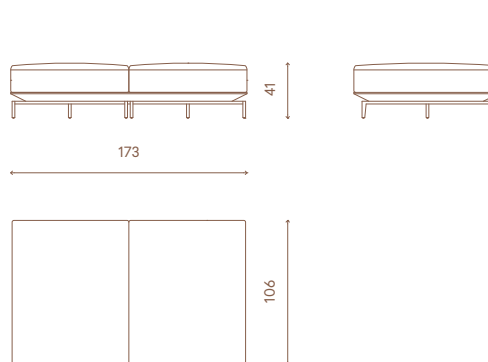

BSCWH10

CHAISE-LONGUE SX  
CHAISE-LONGUE L

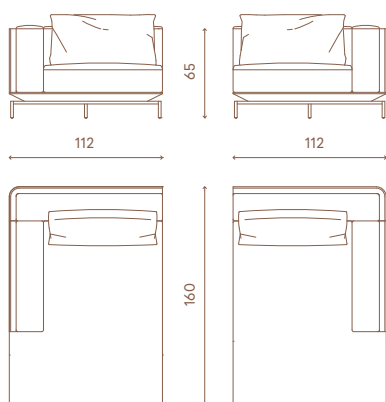

BSDL23

CHAISE-LONGUE DX  
CHAISE-LONGUE R

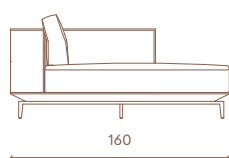

BSDR24

POLTRONA  
ARMCHAIR

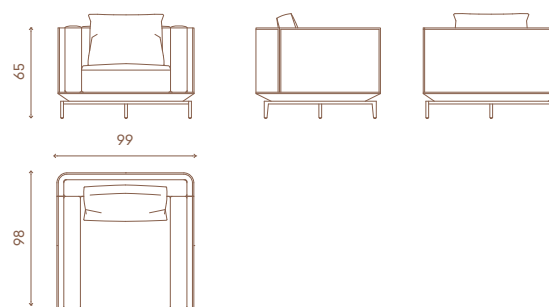

BRACCIOLO  
ARMREST

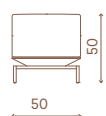

BSBR1

POUF  
POUFFE

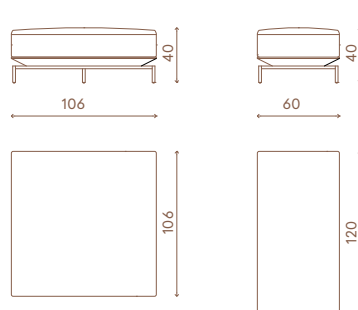

## BACKSTAGE

### Poltroncina Armchair

Design  
Fabio Bonfà

Poltroncina tappezzata in pelle o tessuto, con base composta da un telaio in acciaio inox satinato e un pannello in legno e metallo rivestito in pelle o tessuto, dotato di cinghie elastiche per il molleggio del sedile. Scocca esterna in legno curvo bordato da un profilo in ottone sp.10x10 mm tappezzata con pelle, tessuto oppure pelle intrecciata, imbottita nella parte interna. Cuscino di seduta in poliuretano a diverse densità, memory foam® e piuma. Cuscino di schienale in poliuretano e piuma. Le parti metalliche sono disponibili nella selezione finiture metalliche satinato.

Armchair upholstered in leather or fabric, with base composed of a frame in satinized stainless steel and a panel in wood and metal covered in leather or fabric, equipped with elastic belts for the seat suspension. External shell made of a curved wooden panel edged by a brass profile th.10x10 mm, and upholstered with leather, fabric or woven leather, padded inside. Seat cushion in polyurethane with different densities, memory foam® and feather. Back cushion in polyurethane and feather. Metal parts available in the satinized metal finishing selection.

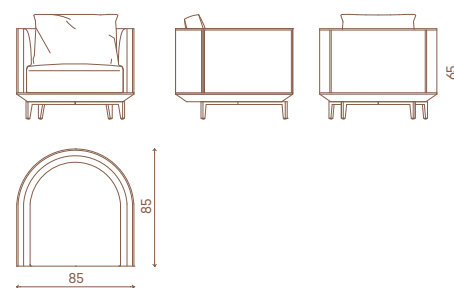

## BAKER

### Tavolo da pranzo Dining table

Design  
Alessandro La Spada

Stelo in metallo cromato, a forma conica con torneria alla base. Top in vetro retrolaccato ad incasso su piano in legno laccato opaco con finitura antigraffio (colori RAL). Parti in metallo anche con finitura laccata oro, bronzo o nickel nero.

Conical shaped support in chrome metal with turned base. Built-in top in lacquered glass on support in mat lacquered scratchproof wooden structure (RAL colours). Metal parts lacquered also gold, bronze or black nickel.

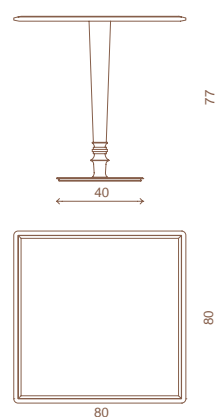

# BALANCE

Divano, Poltrona, Chaise-longue, Pouf  
Sofa, Armchair, Chaise-longue, Pouffe

Design  
Alessandro La Spada

Struttura interna in legno massello e multistrati con molleggio elastico. Scocca sospesa e cuscini di seduta imbottiti con rivestimento fisso, in pelle o tessuto. Schienale alto e fianchi a bergère. Imbottitura in poliuretano a diverse densità, memory foam® e piuma. Cuscini schienale e cuscini volanti in piuma con retro microforato. Base rivestita in acciaio inox satinato. Disponibile pouf quadrato con struttura interna in legno e multistrati, imbottitura in poliuretano a diverse densità. Rivestimento in pelle o tessuto. Le parti metalliche sono disponibili nella selezione finiture metalliche satiniate.

Internal structure in solid wood and plywood with elastic suspension. Suspended shell and upholstered seat cushions with fixed cover, upholster in leather or fabric. High back and bergère sides. Padding in different density polyurethane, memory foam® and feather. Back cushions and down cushions in feather. Base covered in satin stainless steel. Also available pouffe with internal structure in solid wood and plywood, padded in polyurethane with different densities. Upholstery in leather or fabric. Metal parts available in the satinized metal finishing selection.

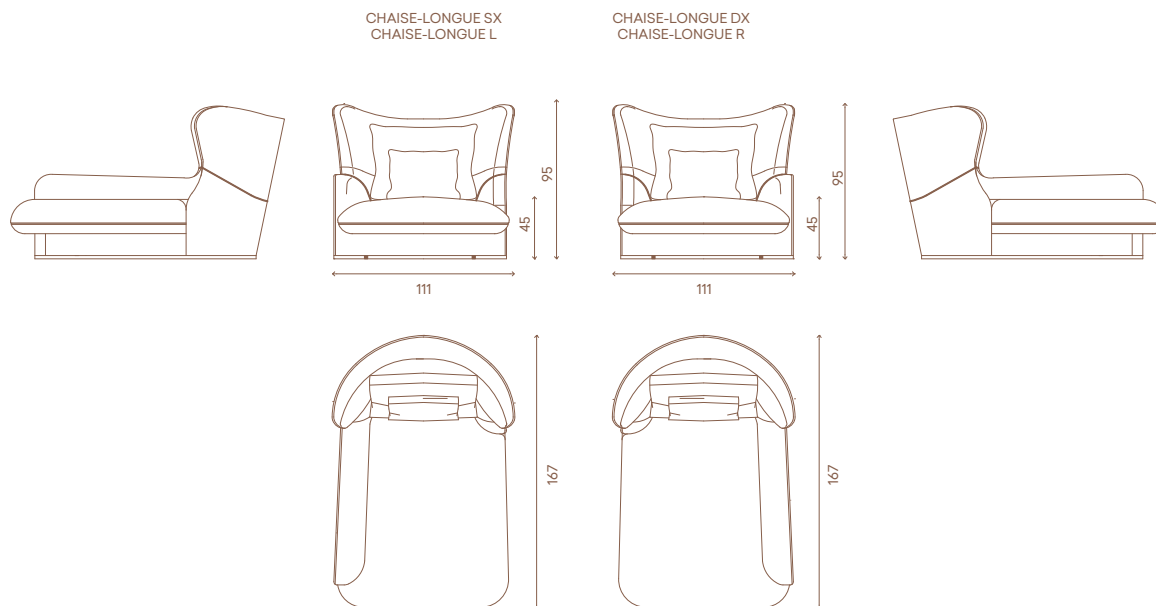
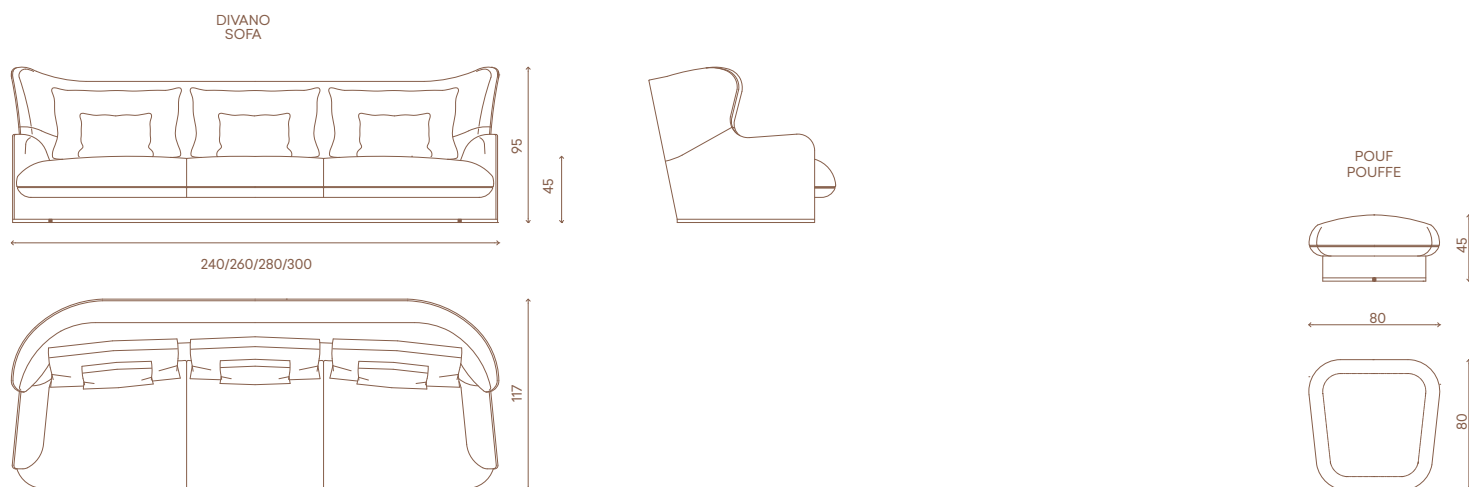

# BALIN

Specchio  
Mirror

Design  
Armando Bruno

Specchio in marmo e vetro accostati a filo, cornice in acciaio satinato. Marmi intarsiati in diverse combinazioni cromatiche. Il sistema di attacco prevede diverse possibilità di orientamento. I marmi sono intarsiati a strisce di Nero Marquina e Arabescato Vagli. Le parti in acciaio sono disponibili nella selezione finiture metalliche satiniate.

Mirror in marble and glass, frame in thin satinized stainless steel. Marbles inlaid in different colour combinations. The attachment system provides various possibilities of orientation. The marbles are inlaid with strips of Nero Marquina and Arabescato Vagli. Metal parts available in the satinized metal finishing selection.

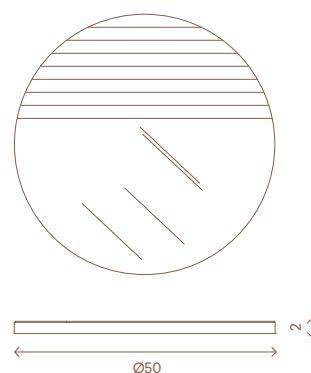

# BANNER

Consolle  
Console

Design  
Fabio Bonfà

Consolle a 2 cassetti in legno scolpito in bassorilievo con disegno a righe verticali, top in marmo con profilo lavorato in negativo. Telaio e profili decorativi in acciaio inox satinato, ripiano portariviste in cristallo fumé.  
I cassetti sono rivestiti internamente in microfibra.

Le parti in legno sono disponibili nelle finiture opache B.180, B.181, B.182, C.001. Le parti metalliche sono disponibili nella selezione finiture metalliche satinato.

*Console with 2 drawers in carved wood in low relief with vertical stripes design, marble top with negative machined profile. Frame and decorative profiles in brushed stainless steel, smoked crystal magazine rack. Drawers internally lined with microfibre. The wooden parts are available in matt finishes B.180, B.181, B.182, C.001. Metal parts available in the satinized metal finishing selection.*

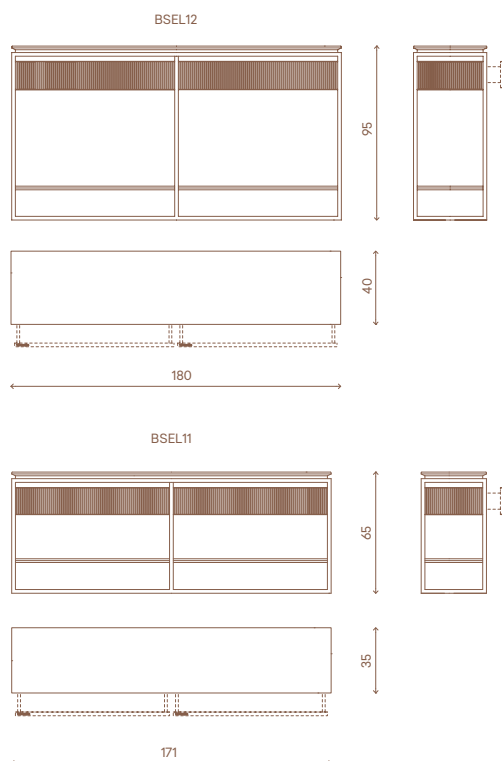

# BANNER

Tavolino  
Low table

Design  
Fabio Bonfà

Tavolo basso a 4 cassetti in legno scolpito in bassorilievo con disegno a righe verticali, top in marmo con profilo lavorato in negativo. Telaio e profili decorativi in acciaio inox satinato. I cassetti sono rivestiti internamente in microfibra. Le parti in legno sono disponibili nelle finiture opache B.180, B.181, B.182, C.001. Le parti metalliche sono disponibili nella selezione finiture metalliche satinato.

*Coffee table with 4 drawers in carved wood in low relief with vertical stripes design, marble top with negative machined profile. Frame and decorative profiles in brushed stainless steel. Drawers internally lined with microfibre. The wooden parts are available in matt finishes B.180, B.181, B.182, C.001. Metal parts available in the satinized metal finishing selection.*

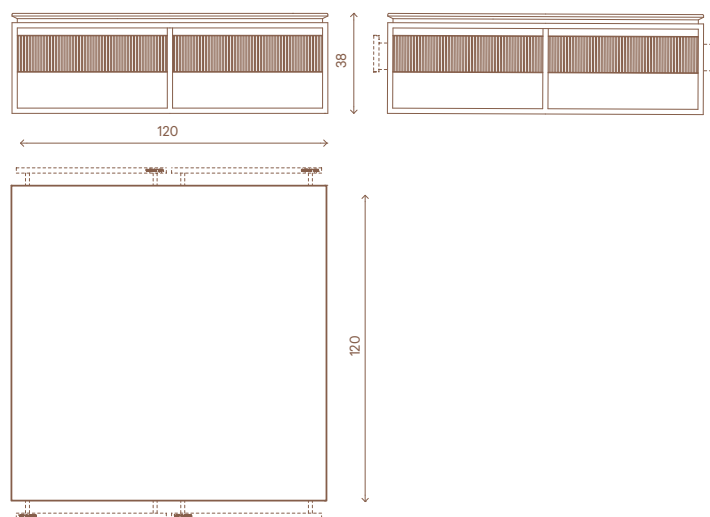

# BARNEY

Cassettiera  
Chest of drawers

Design  
Fabio Bonfà

Cassettiera a 9 cassetti, struttura in mdf rivestita in essenza con inserti in acciaio inox satinato incastonati nel legno, grande maniglione e base in acciaio inox satinato, frontali cassetti in marmo a pieno spessore. Interno laccato opaco, schienale laccato opaco, in opzione disponibile in essenza. Le parti in legno sono disponibili nelle finiture selezione essenze, le parti metalliche sono disponibili nella selezione finiture metalliche.

*Chest of 9 drawers, structure in MDF covered in veneer with inserts in satinized stainless steel embedded in the wood, big drawer handle and base in satinized stainless steel, doors in marble in full thickness, matt lacquered internal parts, matt lacquered backrest, available in veneer wood. Wooden parts available in the veneer finishings selection, metal parts available in the metal finishing selection.*

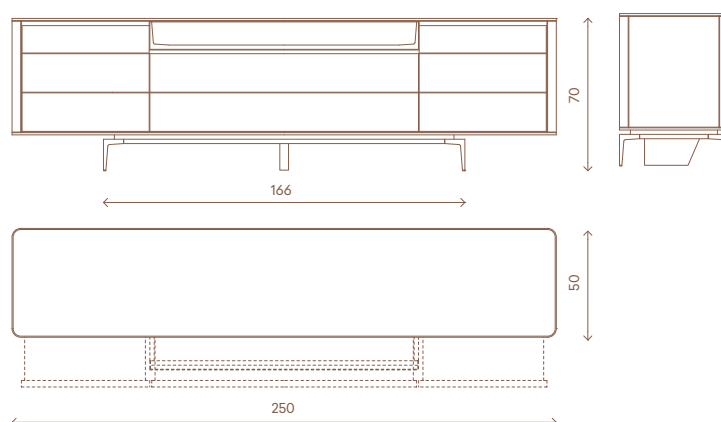

# BASTIAN DUAL

Divano, Elementi componibili  
Sofa, Modular elements

Design  
Mauro Lipparini

Scocca in legno massello e multistrati di abete, imbottitura in poliuretano a densità differenziate e cinghie elastiche sotto ai sedili. Braccioli e schienali realizzati con pannelli imbottiti e decorati con fettuccia in contrasto e filetti in pelle. Seduta composta da cuscino su base in poliuretano, Memory Foam® e copertina in piuma; cuscini schienale in poliuretano e piumino. Fregi su fianchi e retro in acciaio inox satinato a doppia finitura.

Structure in solid wood and fir plywood, padding in polyurethane with different densities and elastic straps under the seats. Armrests and backrests made of padded tiles and decorated with insert in contrasting colour and piping in leather. Seat made of: cushion on polyurethane base, Memory Foam® and feathers cover; back cushions in polyurethane and down. Friezes on lateral sides and rear back in satinized stainless steel with double finishing.

DIVANO  
SOFA

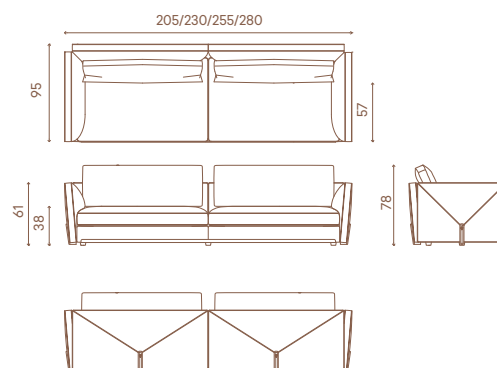
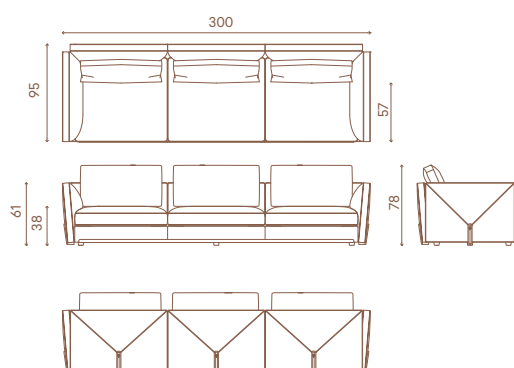

POLTRONA  
ARMCHAIR

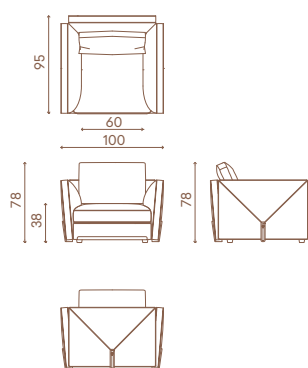

TAVOLINO - BRACCIOLO SX - DX  
LOW TABLE - ARMREST L - R

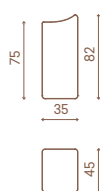

BBL108

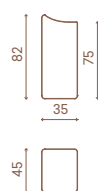

BBR109

ELEMENTO ANGOLARE  
CORNER ELEMENT

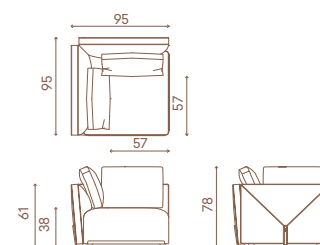

BDA 123

CHAISE-LONGUE DX  
CHAISE-LONGUE R

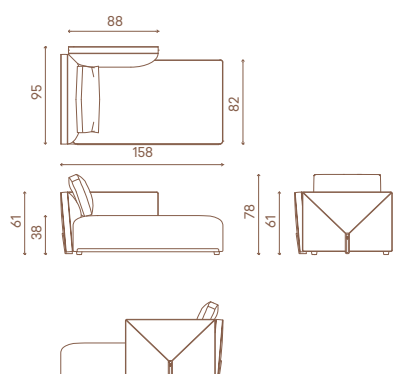

CHAISE-LONGUE SX  
CHAISE-LONGUE L

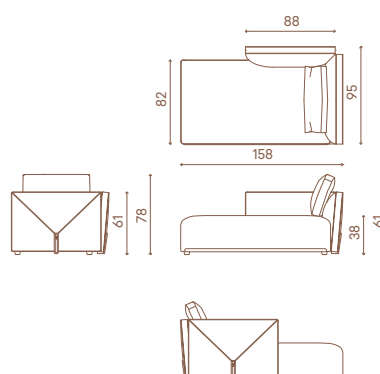



TERMINALI SX  
LATERAL ELEMENT L

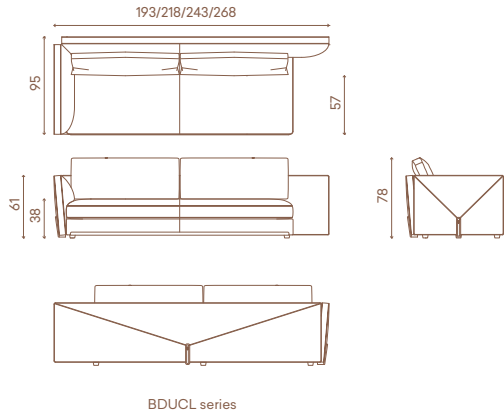

TERMINALI DX  
LATERAL ELEMENT R

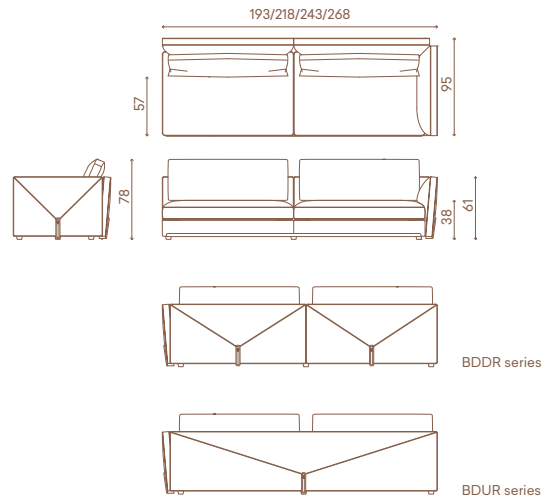
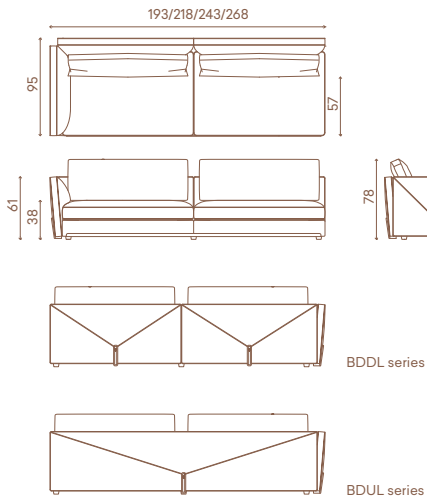
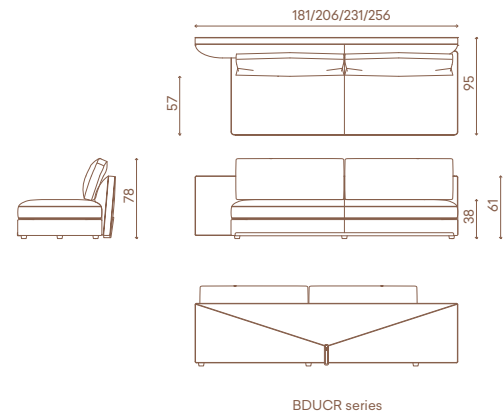
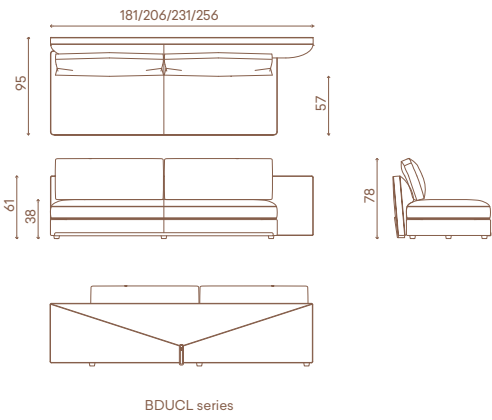
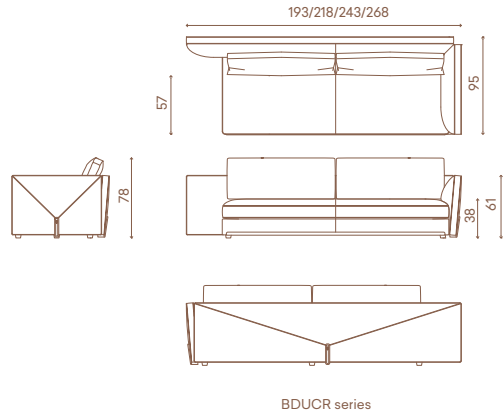

ELEMENTO CENTRALE  
CENTRAL ELEMENT

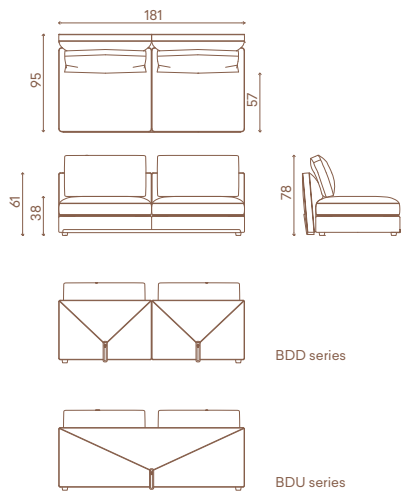

ELEMENTO CENTRALE  
CENTRAL ELEMENT

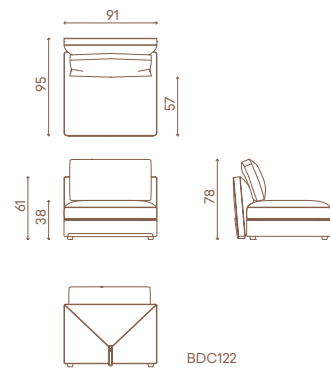

# BASTIAN STILL

Divano, Elementi componibili  
Sofa, Modular elements

Design  
Mauro Lipparini

Scocca in legno massello e multistrati di abete, imbottitura in poliuretano a densità differenziate e cinghie elastiche sotto ai sedili. Braccioli e schienali realizzati con pannelli imbottiti e decorati con fettuccia in contrasto e filetti in pelle. Seduta composta da cuscino monoscocca in poliuretano, Memory Foam® e copertina in piuma e cuscini schienale in poliuretano e piumino. Fregi su fianchi esterni e retro schienali in acciaio inox satinato a doppia finitura.

Structure in solid wood and fir plywood, padding in polyurethane with different densities and elastic straps under seats. Armrests and backrests made of padded tiles and decorated with insert in contrasting colour and pipings in leather. Seat cushion in one piece integrated with the structure, made of polyurethane, Memory Foam® and lining in feathers; back cushions in polyurethane and down. Friezes on external sides and rearback in satinized stainless steel with double finishing.

## POUF - POUFFE

Pouf quadrato con struttura interna in legno massello e multistrati di abete, imbottitura in poliuretano a densità differenziate. Rivestimento in pelle o tessuto. Fettucce decorative ribattute in pelle o tessuto. Filetti in pelle. Disponibile anche con fregi sui fianchi in alluminio satinato e interno in acciaio inox satinato naturale, la cornice esterna è disponibile nella selezione finiture metalliche.

## POUF-POUFFE

Squared pouffe with internal structure in solid wood and fir plywood, padding in polyurethane with different densities. Upholstery in leather or fabric. Decorative inserts with felled seams, made in leather or fabric. Piping in leather. Option also available: friezes on lateral sides in satinized aluminium and internal plate in satinized stainless steel, the external frame in available in the metal finishing selection.

DIVANO  
SOFA

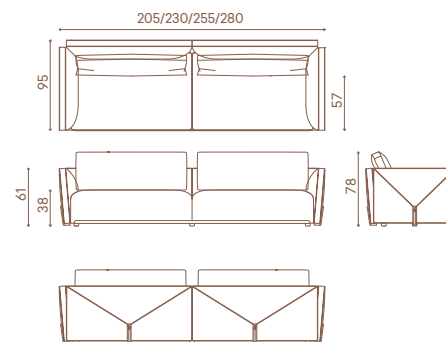
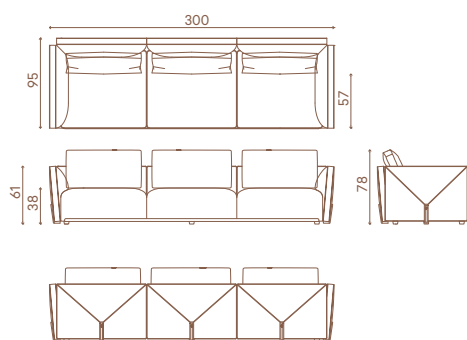

POLTRONA  
ARMCHAIR

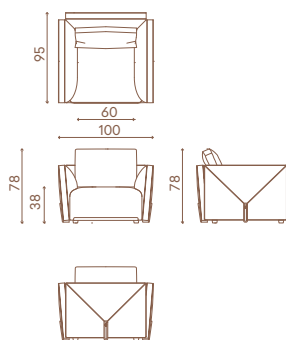

TAVOLINO - BRACCIOLO SX - DX  
LOW TABLE - ARMREST L - R

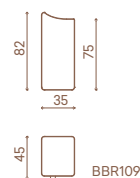
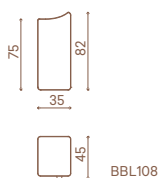

ELEMENTO ANGOLARE  
CORNER ELEMENT

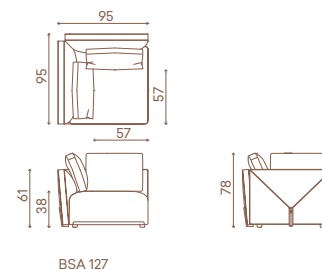

CHAISE-LONGUE DX  
CHAISE-LONGUE R

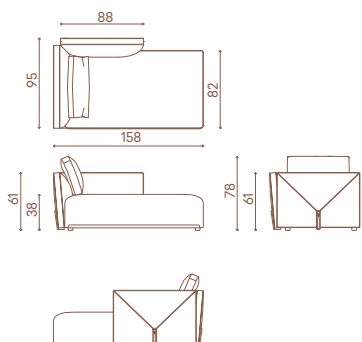

CHAISE-LONGUE SX  
CHAISE-LONGUE L

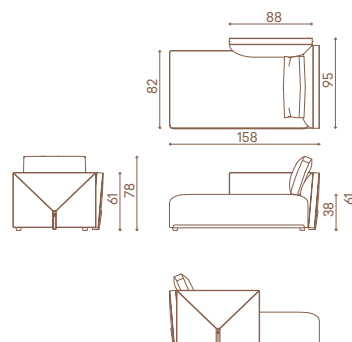

TERMINALI SX  
LATERAL ELEMENT L

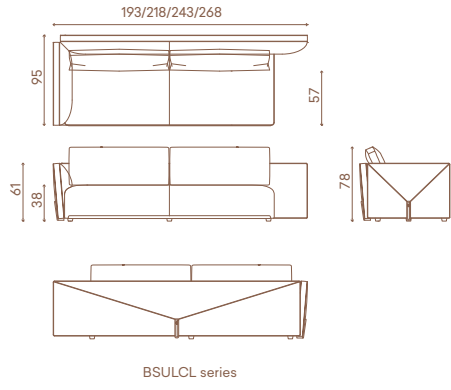

TERMINALI DX  
LATERAL ELEMENT R

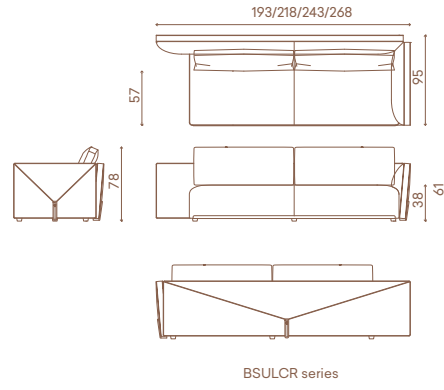

181/206/231/256

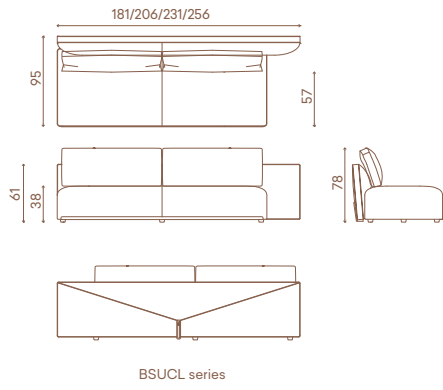

181/206/231/256

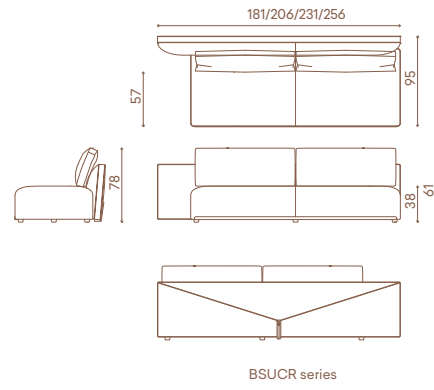

268/243/218/193

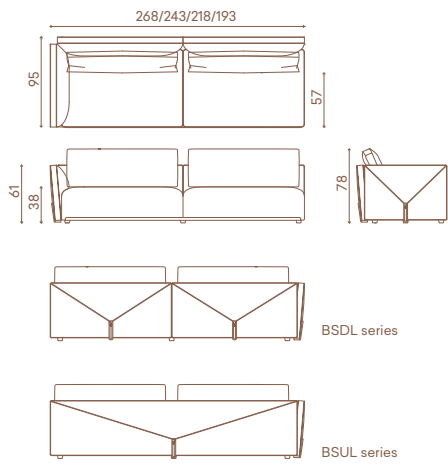

BSDL series

BSUL series

268/243/218/193

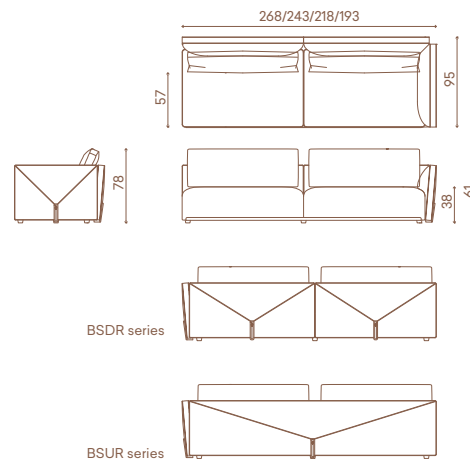

BSDR series

BSUR series

ELEMENTO CENTRALE  
CENTRAL ELEMENT

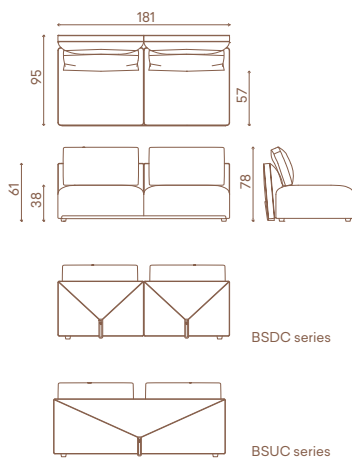

BSDC series

BSUC series

POUF  
POUFFE

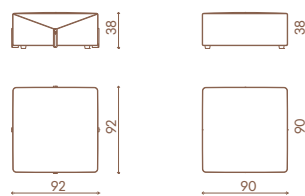

ELEMENTO CENTRALE  
CENTRAL ELEMENT

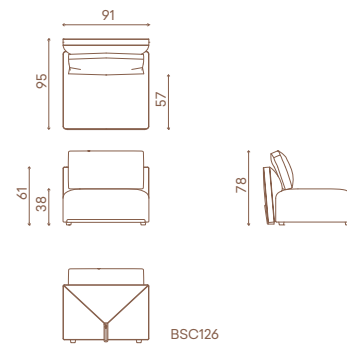

BSC126

# BASTIAN DUAL-STILL

Esempi di composizione  
Composition samples

Design  
Mauro Lipparini

Divano Componibile - Composizione 01  
Modular Sofa - Composition 01  
BDUL13  
BBR109  
BDUCR38  
BDUCR28  
AURYN TAVOLINO/AURYN LOW TABLE

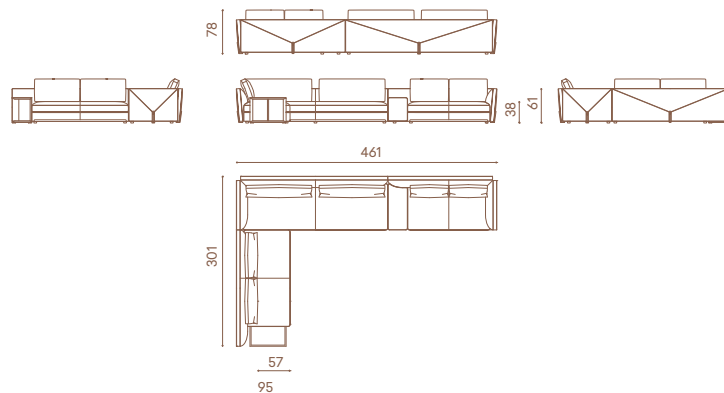

Divano Componibile - Composizione 02  
Modular Sofa - Composition 02  
BDDL1  
CHAISE-LONGUE DX

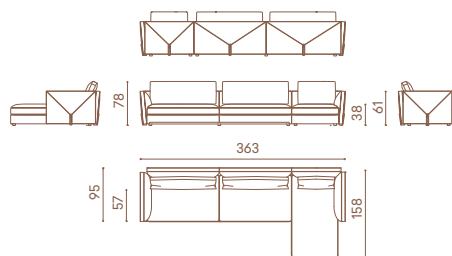

Divano Componibile - Composizione 03  
Modular Sofa - Composition 03  
BDUCR34  
BBR109  
BDUCR28  
AURYN TAVOLINO/AURYN LOW TABLE

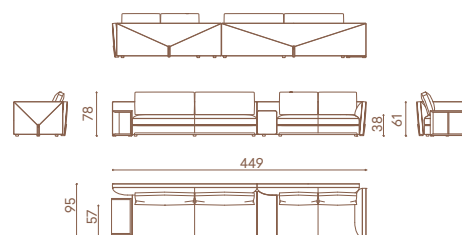

Divano Componibile - Composizione 04  
Modular Sofa - Composition 04  
BDDL1  
BDUCL25  
BBL108

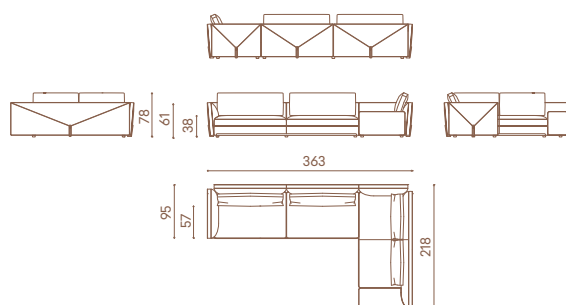

Divano Componibile - Composizione 05  
Modular Sofa - Composition 05  
BDUL13  
POUFF STILL/POUFFE STILL  
BSUCL67  
AURYN TAVOLINO/AURYN LOW TABLE

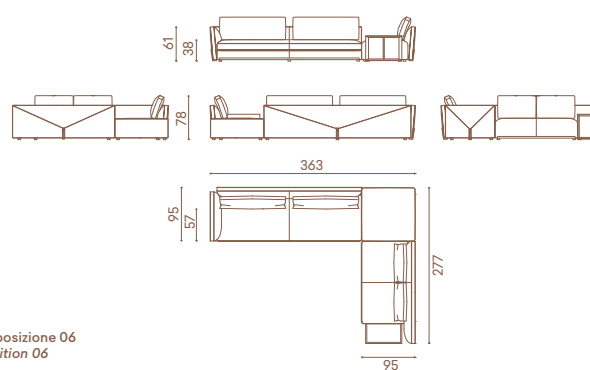

Divano Componibile - Composizione 06  
Modular Sofa - Composition 06  
BSDL110  
BSULL41  
BBR109  
BSUCR66  
DIVANO DUAL 280  
NR. 2 POUFF STILL/NR. 2 POUFFE STILL

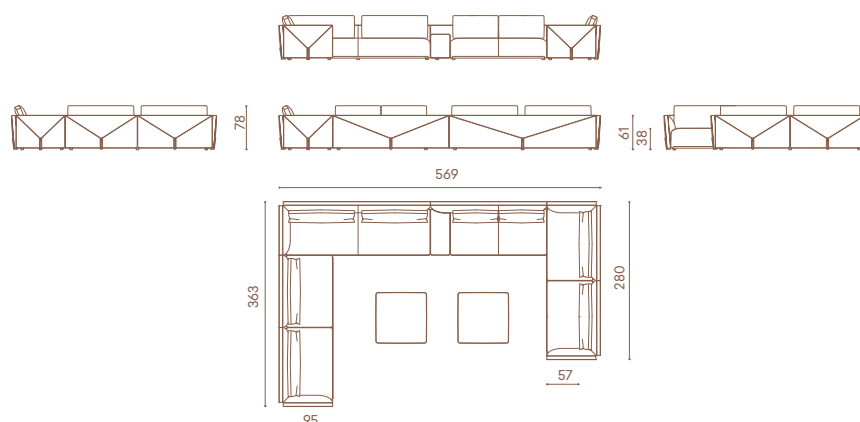

# BELAR

Tappeto  
Carpet

Design  
Alessandro La Spada

Tappeto taftato a mano 100% Bamboo Silk, grafica a mosaico marmorizzato. Un angolo ospita un inserto in ottone satinato con logo Visionnaire inciso in bassorilievo. Backing in cotone.

*Hand-tufted carpet. 100% bamboo silk, "marble-look mosaic" pattern. A corner contains an insert in satinized brass with Visionnaire logo engraved in bas-relief. Backing in cotton.*

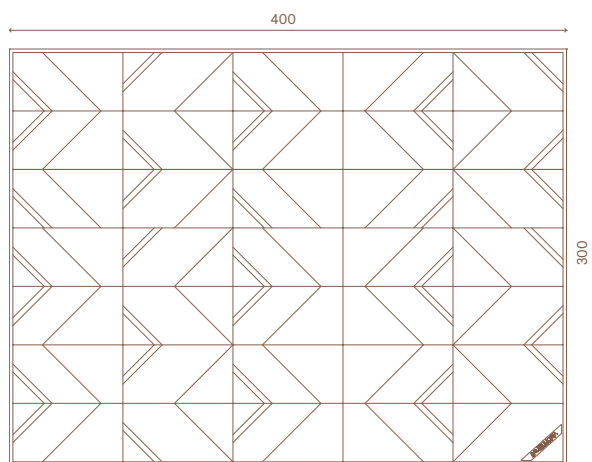

# BLONDIE

Panca  
Bench

Design  
La Conca

Struttura in massello e multistrati di pioppo sagomato, imbottitura in poliuretano espanso a densità differenziate e molleggio seduta a cinghie elastiche. Seduta imbottita in Memory Foam® rivestita internamente in pelle o tessuto trapuntato a porzioni singolarmente imbottite. Rivestimento esterno in pelle o tessuto liscio, filetti in pelle. Base e piedi in legno di faggio massello rivestito in essenza con angolari e piedini in acciaio inox satinato. Scocca e piedi sono disponibili nelle finiture selezione essenze; le parti metalliche sono disponibili nella selezione finiture metalliche satiniate.

*Structure in solid wood and shaped poplar plywood, padding in polyurethane foam with different densities and elastic straps springing system. Seat padded in Memory Foam® internally upholstered in leather or fabric, quilted portions padded one-by-one. External upholstery in leather or smooth fabric, pipings in leather. Base and feet in beech solid wood covered in veneer with corner elements and feet pads in satinized stainless steel. Structure and feet available in the veneer finishing selections; metal parts available in the satinized metal finishing selection.*

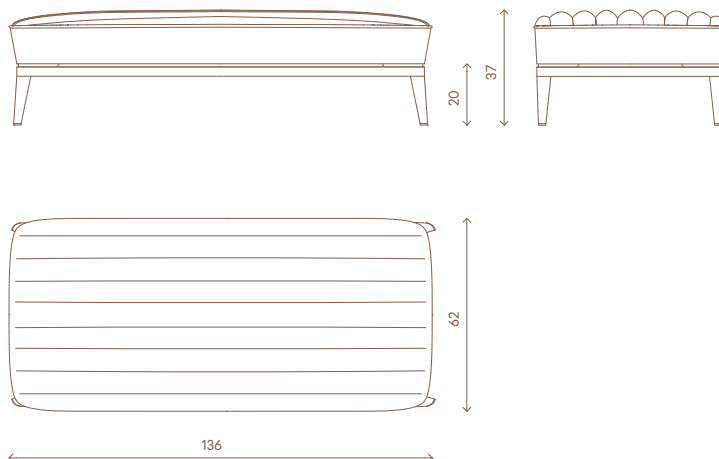

# BLONDIE

Poltrona  
Armchair

Design  
La Conca

Struttura in massello e multistrati di pioppo sagomato, imbottitura in poliuretano espanso a densità differenziate e molleggio seduta a cinghie elastiche. Seduta e schienale imbottiti in Memory Foam® rivestiti internamente in pelle o tessuto trapuntato a porzioni singolarmente imbottite. Rivestimento esterno in pelle o tessuto liscio, filetti in pelle. Base e piedi in legno di faggio massello rivestito in essenza con angolari e piedini in acciaio inox satinato. Scocca e piedi sono disponibili nelle finiture selezione essenze; le parti metalliche sono disponibili nella selezione finiture metalliche satiniate.

*Structure in solid wood and shaped poplar plywood, padding in polyurethane foam with different densities and elastic straps springing system. Seat and backrest padded in Memory Foam® internally upholstered in leather or fabric, quilted portions padded one-by-one. External upholstery in leather or fabric, leather pipings. Base and feet in beech wood with corner profiles in satinized stainless steel. Base and feet are available in the veneer finishings selection; metal parts available in the satinized metal finishing selection.*

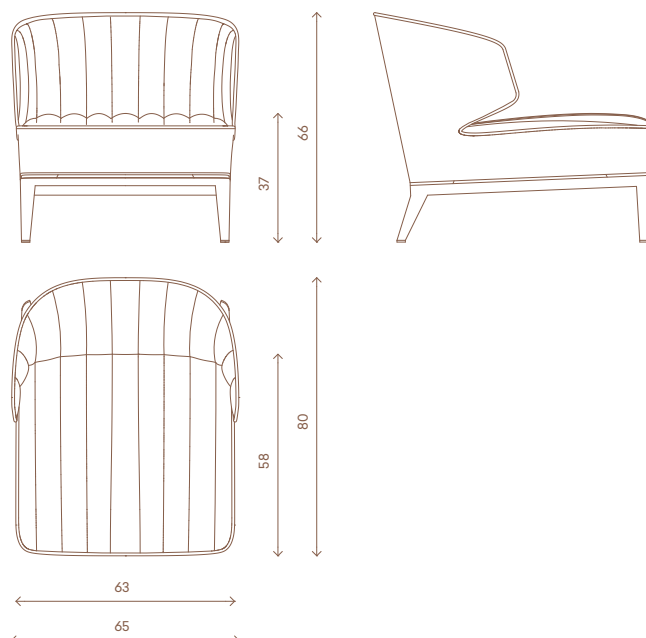

# BINKLEY

Tappeto  
Carpet

Design  
La Conca

Tappeto taftato a mano in bamboo silk e lana New Zealand con lavorazione carving manuale. Backing in cotone.

*Hand-tufted carpet in bamboo silk and New Zealand wool with carving work. Cotton backing.*

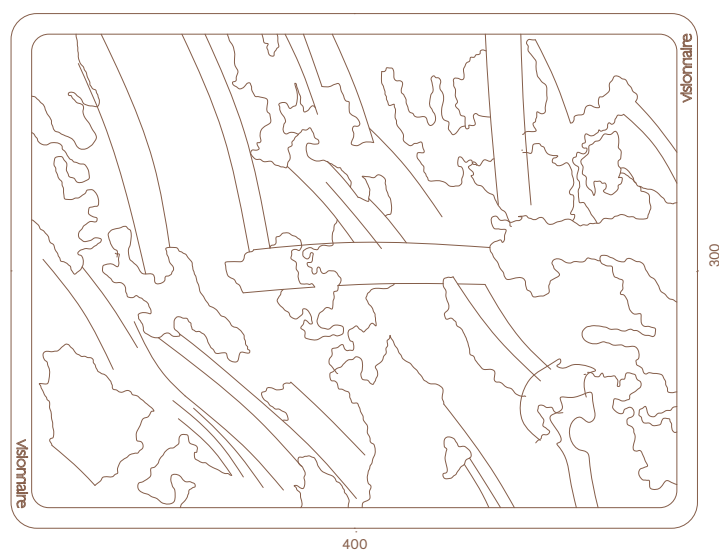

# BRANDO

Applique  
Wall Lamp

Design  
Samuele Mazza

Applique in metallo e onice. Struttura portante in acciaio e ottone con finitura satinata cromo o oro. Paralumi in Onice Velluto sp. 8 mm sospesi a formare una figura sfaccettata e illuminati da un impianto di 4 luci G9 max 40 W cad. Assorbimento max 160W, peso 10 kg.

*Wall lamp in metal and onyx. Main structure in steel and brass with satinized chromed or gold finishings. Lampshades in Ivory Onyx, 8 mm in width, creating a multi-faceted effect. Lighting system for 4 light bulbs G9 max 40W each, max 160W in total, weight 10 kg.*

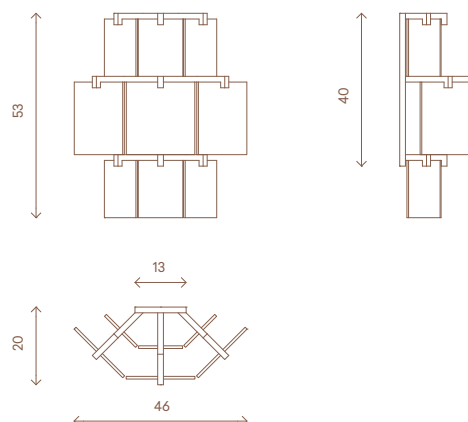

# BRANDO

Lampadario ottagonale  
Octagonal Chandelier

Design  
Samuele Mazza

Sospensione ottagonale. Struttura portante in acciaio e ottone con finitura satinata cromo o oro. Paralumi in onice Velluto sp. 8 mm sospesi a formare una figura sfaccettata e illuminati da un impianto di 13 luci G9 max 40W cad. Assorbimento max 520 W, peso 25 kg. Sospensione su catena a maglie ottagonali.

*Octagonal suspended chandelier. Main structure in steel and brass with satinized chromed or gold finishings. Lampshades in Ivory Onyx, 8 mm in width, creating a multi-faceted effect. Lighting system for 13 light bulbs G9 max 40W each. Max 520W in total, weight 25 kg. Two-point suspension with octagonal link chains.*

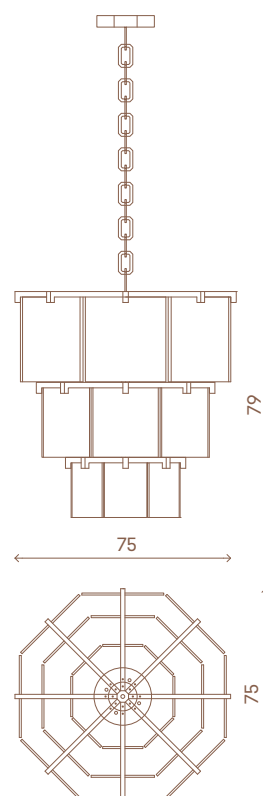

# BRANDO

## Lampadario Chandelier

Design  
Samuele Mazza

Struttura portante in acciaio e ottone con finitura satinata cromo o oro. Paralumi in onice Velluto sp. 8 mm sospesi a formare una figura sfaccettata e illuminati da un impianto di 13 luci G9 max 40W cad. Assorbimento max 520 W, peso 25 kg. Sospensione su catena a maglie ottagonali.

Main structure in steel and brass with satinized chromed or gold finishings. Lampshades in Ivory Onyx, 8 mm in width, creating a multi-faceted effect. Lighting system for 13 light bulbs G9 max 40W each. Max 520W in total, weight 25 kg. Two-point suspension with octagonal link chains.

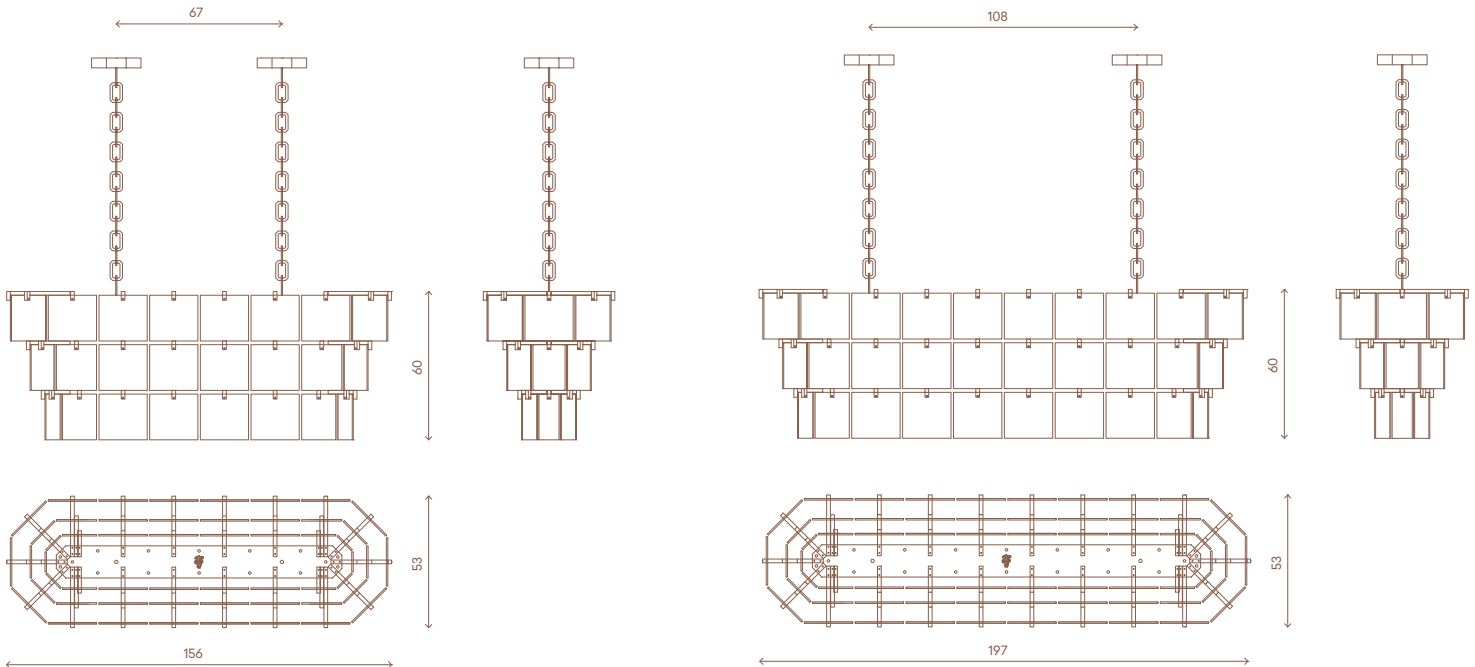

# BREEZE

## Tavolo basso Low Table

Design  
Roberto Tapinassi - Maurizio Manzoni

### Versione Indoor

Tavolino a tre piedi in legno di frassino massello, con fregi e piedini in ottone inciso satinato. Top in vetro stratificato double-face con stampa digitale e sfondo nero e foglia oro o argento, retro nero. Struttura disponibile nelle tonalità "MAS" in finitura lucida 100 gloss. La parti metalliche sono disponibili nella selezione finiture metalliche satinato.

### Indoor version

Three-foot table in ash solid wood, with decorations and feet in satinized engraved brass. Top in double face laminated glass with digital print, black background and gold or silver leaf, black rear back. Structure available in colours MAS 1, 2, 3, 4, 5 in 100 gloss shiny lacquer. Metal parts available in the finishes included in the metal finishing selection.

### Versione Outdoor

Tavolino a tre piedi in legno di iroko massello, con fregi e piedini in ottone inciso satinato. Top in vetro stratificato double-face con stampa digitale e sfondo verde scuro e foglia oro o argento, retro nero. Struttura disponibile nelle tonalità: iroko naturale, biscotto e testa di moro, a poro aperto. La parti metalliche sono disponibili nella selezione finiture metalliche satinato. Disponibile in opzione finitura poliestere lucida.

### Outdoor version

Three-foot table in iroko solid wood, with decorations and feet in satinized engraved brass. Top in double face laminated glass with digital print, dark green background and gold or silver leaf. Structure available in: natural iroko, biscuit and dark brown, mat open-pore finishing. Metal parts available in the satinized metal finishing selection. Available also in polished polyester finishing.

Gli accoppiamenti disponibili sono: libellula e foglia oro (top da Ø120 cm), coleottero nero e foglia oro oppure farfalla e foglia argento (top da Ø60 cm), coleottero verde e foglia argento oppure colibrì e foglia argento (top da Ø50 cm), cervo volante e foglia argento oppure pesci lottatori e foglia oro (top da Ø40 cm).

The possible matchings are: dragonfly and gold leaf (top diam. 120 cm); black beetle and gold leaf or butterfly and silver leaf (top diam. 60 cm); green beetle and silver leaf or hummingbird and silver leaf (top diam. 50 cm); stag beetle and silver leaf or Siamese fighter fishes and gold leaf (top diam. 40 cm).

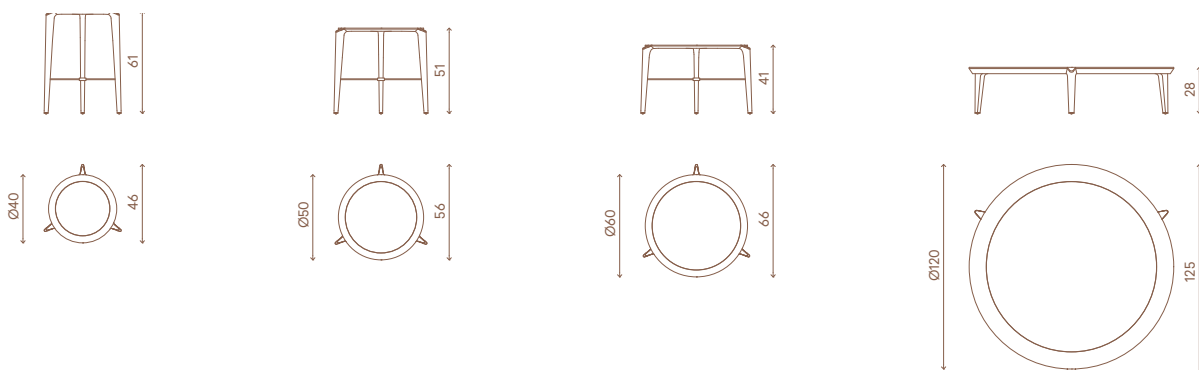

# BRONSON

Mobile basso  
Low unit

Design  
Giuseppe Viganò

Mobile basso in legno rivestito in essenza con fianchi sagomati e top centrale in marmo. Quattro ante in essenza e un cassetto con frontale in marmo con bordi accoppiati a 45°, maniglie in acciaio satinato. Interno in legno laccato 100 gloss e ripiani in cristallo extrachiaro sp.8 mm. Il cassetto è rivestito internamente in microfibra. Base in acciaio inox satinato. Le parti in legno sono disponibili nelle finiture selezione essenze, le parti metalliche sono disponibili nella selezione finiture metalliche.

*Low cabinet in veneered wood with shaped sides and marble top. Four doors in wood and a drawer with marble front with edges coupled to 45°, handles in satin finish 100 gloss lacquered wood interior and extra-clear glass shelves th.8 mm. Drawer internally lined in microfibre. Base in satin stainless steel. Wooden parts available in the veneer finishings selection, metal parts available in the metal finishing selection.*

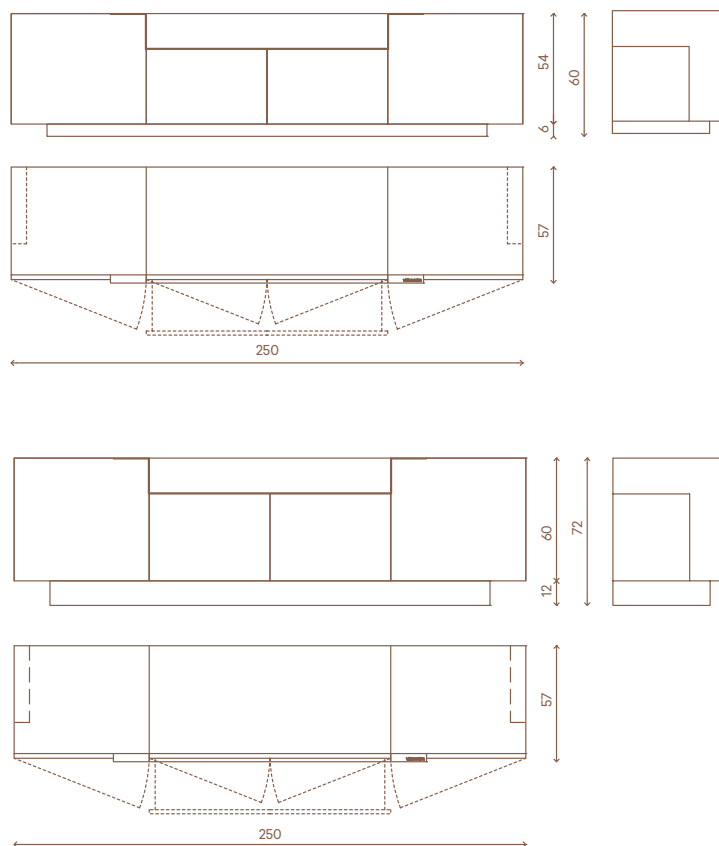

# BRUNILDE

Applique  
Wall lamp

Design  
Alessandro La Spada - Samuele Mazza

Coni ricurvi e lancia centrale in ottone cromato; particolari in alluminio tornito; piastra di fissaggio in acciaio. Paralume ovale tronco conico in seta crema o in opzione, in seta nera e interno in materiale riflettente oro, per la versione "all", in scaglie di alluminio naturale con opzione possibilità di applicazione pendenti in cristallo Swarovski. Applique cm 159 predisposta per l'utilizzo di nr. 2 lampadine E27 max 75 W cad. Peso kg 10,5. Applique cm 104 predisposta per l'utilizzo di nr. 2 lampadine E27 max 75 W cad. Peso kg 6,90. Applique unicorno cm. 65 predisposta per l'utilizzo di nr. 1 lampadina E14 max 60 W. Peso kg 5.

*Curved cones and central lance in chromed brass; details in lathed aluminium; plate for fixing to wall in steel. Oval lampshade of conical truncated cone in cream silk, or option, black silk and gold inner reflective material, for "all" version, shape in natural aluminium plates with possibility of application of pendants in Swarovski crystals. Wall light 159 cm prepared for use with 2 light bulbs E27 max 75 W each - Weight kg 10,5. Wall light 104 cm prepared for use with 2 light bulbs E27 max 75 W each - Weight kg 6,90. Wall light 65 cm prepared for use with 1 light bulb E14 max 60 W. Weight kg 5.*

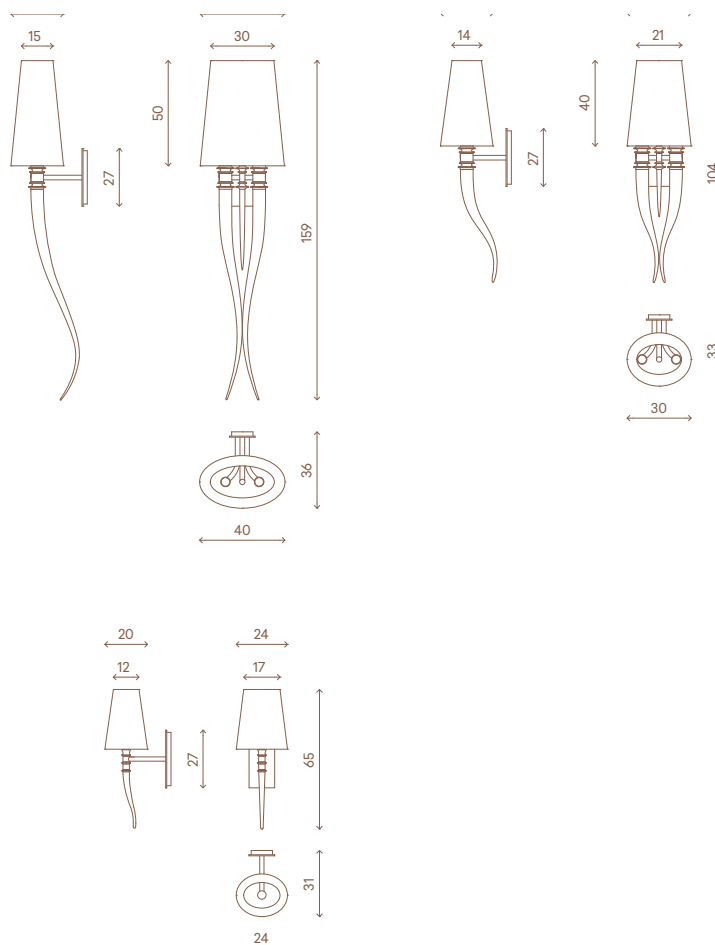



# CARMEN STEEL

Sedia  
Chair

Design  
Alessandro La Spada

Struttura schienale in multistrato curvo di pioppo, base tubolare in acciaio satinato sagomato e curvato, sedile in multistrato cinghiato con nastri elastici 60 mm incrociati. Imbottitura sedile in poliuretano e lastra di Memory Foam®. Imbottitura schienale in poliuretano a densità differenziata. Rivestimento interno in pelle o tessuto lisci. Rivestimento esterno trapuntato con lavorazione disegno "cannettè". Le parti metalliche sono disponibili nella selezione finiture metalliche satiniate.

*Rearback structure in curved poplar plywood, tubular base in satinized steel, shaped and curved, seat in plywood with interwoven elastic straps 60 mm. Seat padding in polyurethane and layer in Memory Foam®. Rearback padding in polyurethane with different densities. Internal upholstery in leather or fabric. External upholstery quilted with cannettè decorative motive. Metal parts available in the satinized metal finishing selection.*

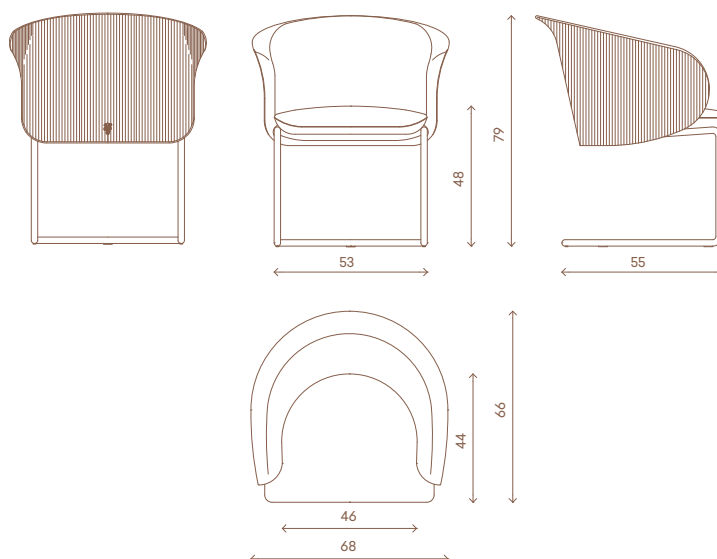

# CARMEN PADDED

Sedia  
Chair

Design  
Alessandro La Spada

Struttura schienale in multistrato curvo di pioppo, base tubolare in acciaio satinato sagomato e curvato, sedile in multistrato cinghiato con nastri elastici 60 mm incrociati. Imbottitura sedile in poliuretano e lastra di Memory Foam®. Imbottitura schienale in poliuretano a densità differenziata. Rivestimento interno in pelle o tessuto lisci. Rivestimento esterno trapuntato con lavorazione disegno "cannettè". Le parti metalliche sono disponibili nella selezione finiture metalliche satiniate.

*Rearback structure in curved poplar plywood, tubular base in satinized steel, shaped and curved, seat in plywood with interwoven elastic straps 60 mm. Seat padding in polyurethane and layer in Memory Foam®. Rearback padding in polyurethane with different densities. Internal upholstery in leather or fabric. External upholstery quilted with cannettè decorative motive. Metal parts available in the satinized metal finishing selection.*

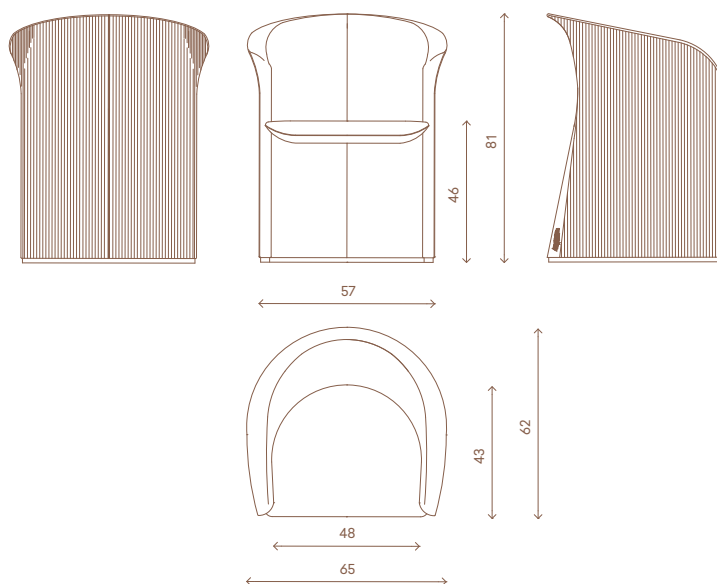

# CONWAY

Tappeto  
Carpet

Design  
La Conca

Tappeto taftato a mano in bamboo silk e lana New Zealand con lavorazione carving manuale. Backing in cotone.

*Hand-tufted carpet in bamboo silk and New Zealand wool with carving work. Cotton backing.*



# CYBORG HIGH CYBORG LARGE

Tavolino  
Small Table

Design  
Alessandro La Spada

Struttura in legno a pianta sfalsata con rivestimento esterno sagomato in acciaio inox satinato o pelle, base in acciaio inox satinato, top a doppia altezza in marmo o essenza nelle finiture selezione essenze, logo Visionnaire in acciaio applicato sul bordo verticale. Disponibile in due varianti con top in legno e fianchi in acciaio satinato o con top in marmo e fianchi in pelle. Le parti metalliche sono disponibili nella selezione finiture metalliche satinato.

Structure in wood with staggered base with external shaped cover in satinized stainless steel or leather, base in satinized stainless steel, top with double height in marble or in veneered wood (available in the finishes included in the veneer selection), Visionnaire logo in steel applied on vertical profile. Two versions available: top in wood and laterals in satinized steel; or top in marble and laterals in leather. Metal parts available in the satinized metal finishing selection.

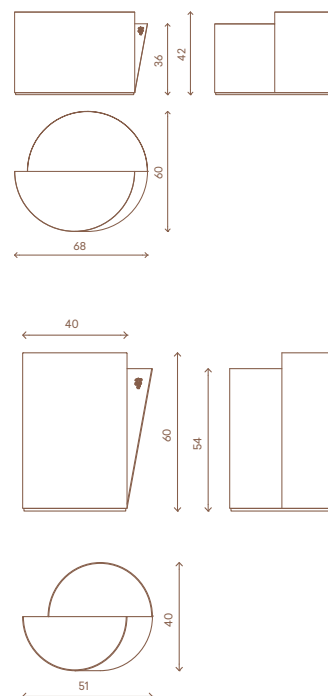

# DANNY

Mobile basso  
Low unit

Design  
Mauro Lipparini

Mobile basso a quattro ante, scocca del mobile in legno con lato esterno laccato lucido e superficie interna rivestita in acciaio satinato. Top e ante rivestite in essenza laccata al poliestere lucido, profili top in metallo satinato. Le parti in acciaio sono disponibili nella selezione finiture metalliche. Top e ante sono disponibili nelle finiture selezione essenze.

Low cabinet with four doors, main structure in wood with external side coated in satinized steel. Top and doors in veneered wood in glossy lacquered finishing, top profiles in satinized metal. Metal parts available in the metal finishing selection. Top and doors available in veneer selection finishings.

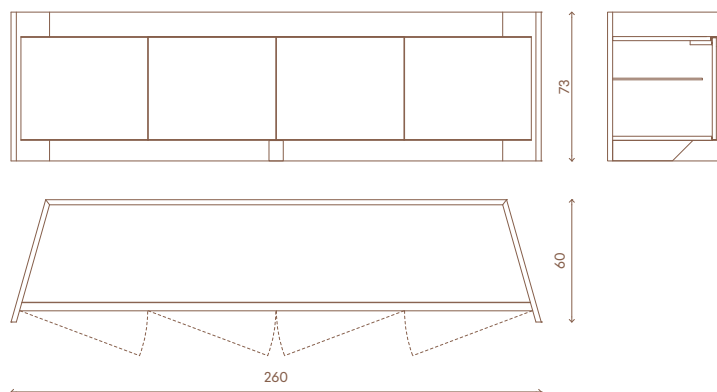

# EKOS

Consolle  
Console

Design  
Alessandro La Spada

Consolle in legno con top e gambe concavi rivestiti in essenza con finitura lucida 100 gloss, la parte interna è rivestita in acciaio inox lucido curvato. Secondo top parziale in cristallo fumé. Le parti in metallo sono disponibili nella selezione finiture metalliche, le parti in legno sono disponibili nelle finiture selezione essenze.

Consolle in marmo massello con top e gambe a lavorazione concava lucidata a mano, la parte interna è rivestita in acciaio inox lucido curvato. Secondo top parziale in cristallo fumé. Le parti in metallo sono disponibili nella selezione finiture metalliche, le parti in legno sono disponibili nelle finiture selezione essenze.

Console in wood with polished veneered concave legs and top, the inside part is covered in curved polished stainless steel. Second partial top in smoked crystal. Metal parts available in the metal finishing selection, wooden parts available in the veneer selection finishings.

Console in solid marble with concave work for top and legs, handmade polished. The inside part is covered in curved polished stainless steel. Second partial top in smoked crystal. Metal parts available in the metal finishing selection, wooden parts available in the veneer selection finishings.



# EKOS

**Panca**  
**Bench**

**Design**  
Alessandro La Spada

Panca imbottita con seduta lineare rivestita in pelle o tessuto, basamento rivestito in acciaio inox lucido curvato, con elementi laterali in marmo massello a forma concava. Le parti in acciaio sono disponibili nella selezione finiture metalliche. La seduta è disponibile anche nella versione "quilted" in pelle con ricamo con disegno foliage, leggermente imbottito.

*Upholstered bench with linear seat in leather or fabric, base covered in curved polished stainless steel, with concave-shaped solid marble side elements. Metal parts available in the metal finishing selection. The seat is also available in the "quilted" version in leather with embroidery with a slightly padded, foliage design.*

VERSIONE QUILTED  
QUILTED VERSION

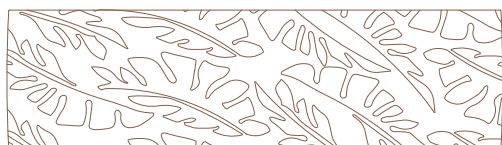

# ELDER

**Lampada da tavolo**  
**Table lamp**

**Design**  
Fabio Bonfà

Struttura in acciaio inox satinato con inserto in legno nero lucido e base in marmo, portalampade E27 max 60W, paralume in tessuto intrecciato o raso nero con interno bianco. Le parti in acciaio sono disponibili nella selezione finiture metalliche satinato.

*Structure in satinized stainless steel with insert in shiny black lacquered wood and base in marble, bulb E27 max 60W, lampshade in woven fabric or black satin with white interior. Metal parts available in the satinized metal finishing selection.*

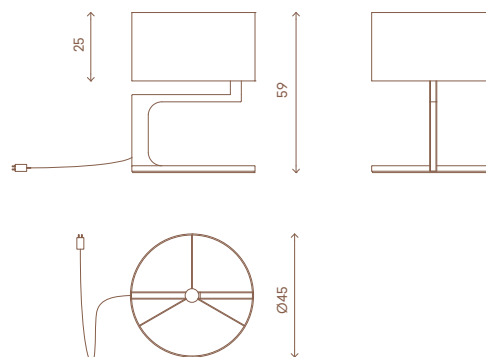

# ELDER

**Piantana**  
**Floor Lamp**

**Design**  
Fabio Bonfà

Struttura in acciaio inox satinato con inserto in legno nero lucido e base in marmo, portalampade E27 max 60W, paralume in tessuto intrecciato o raso nero con interno bianco. Le parti in acciaio sono disponibili nella selezione finiture metalliche satinato.

*Structure in satinized stainless steel with insert in shiny black lacquered wood and base in marble, bulb E27 max 60W, lampshade in woven fabric or black satin with white interior. Metal parts available in the satinized metal finishing selection.*

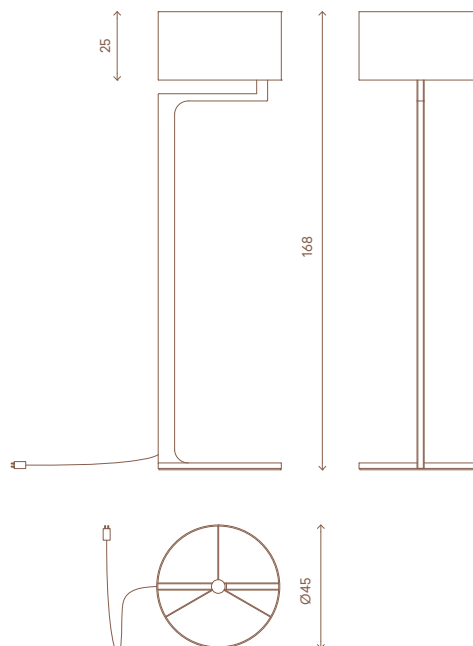

# ELMO

Specchio  
Mirror

Design  
Armando Bruno

Specchio in marmo e vetro accostati a filo, cornice in acciaio satinato. Porzione di marmo intarsiato Arabescato Vagli. Il sistema di attacco prevede diverse possibilità di orientamento. Le parti in acciaio sono disponibili nella selezione finiture metalliche satiniate.

*Mirror in marble and glass, frame in thin satinized stainless steel. Portion of inlaid marble Arabescato Vagli. The attachment system provides various possibilities of orientation. Metal parts available in the satinized metal finishing selection.*

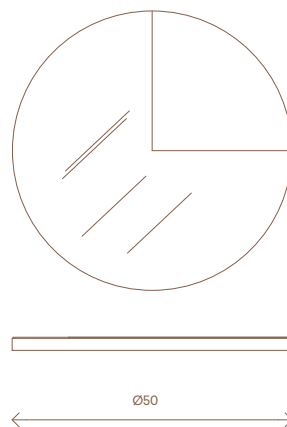

# EQUINOX

Consolle Bar  
Bar Console

Design  
Mauro Lipparini

Consolle bar con struttura in multistrati e MDF con finitura laccata in colori RAL o perlati, oppure in essenza con finitura lucida. Pannello frontale in marmo lavorato ad arco con inserti in acciaio inox naturale e pelle. Fregio decorativo centrale e telaio esterno in acciaio inox satinato disponibile nella selezione finiture metalliche. Top apribile a ribalta con cerniere smorzate e vano interno laccato opaco con fondo a specchio e ripiani in cristallo extrachiaro. Mobile predisposto per attacco a parete. Opzione: impianto audio bluetooth integrato composto da 2 diffusori tweeter-mid range e una unità subwoofer (potenza max 400W) con prese USB per ricarica di dispositivi portatili.

*Bar console with structure in plywood and MDF lacquered in RAL or pearlized colours or in veneer with shiny finishing. Front panel in marble with "arch" manufacture, with inserts in natural stainless steel and in leather. Central decoration and external frame in satinized stainless steel available in the satinized metal finishing selection. Flap top with damped hinges and internal part in mat lacquer with mirror bottom and shelves in extraclear crystal. Predisposed for wall fixing. Option: integrated Bluetooth audio system with 2 tweeter-mid range diffusers and 1 subwoofer unit (max 400W) with USB sockets for recharge of portable devices.*

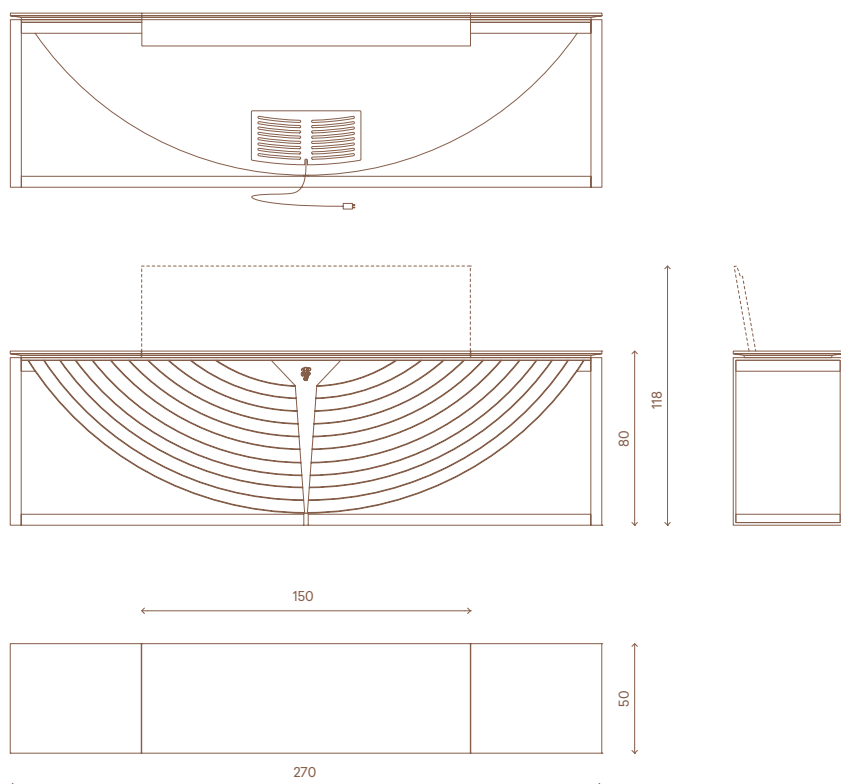

# EMOTION

Letto  
Bed

Design  
La Conca

Letto tappezzato in pelle o tessuto. Struttura della testata in legno impiallacciato in essenza laccata lucida in multistrati con pannelli rivestiti singolarmente, con vani a giorno e due vani nascosti con apertura a ribalta a richiesta, rivestiti internamente in pelle o tessuto. Comodini con cassetto integrati. Zoccolo di testata e sommier in legno, inserti in acciaio inox satinato, predisposizione per attacco a parete. Giroletto in multistrati imbottito in poliuretano. Rete a doghe in legno, supporto rete costituito da quattro angolari più traversa centrale, regolabili in altezza, in acciaio verniciato. Fornito con illuminazione a LED in tutti i vani. Le parti metalliche sono disponibili nella selezione finiture metalliche. Abbinabile a set lenzuola, cuscini e copriletto Secret

Bed upholstered in leather or fabric. Structure of the headboard in plywood covered in veneered wood with polish lacquering, padded panels upholstered one-by-one, two hidden storage compartments with flap-door opening system, internally upholstered in leather or fabric. Integrated bedside table. Headboard and bedframe plinth in wood, inserts in satinized stainless steel. Equipped for wall-mounting. Bedframe in plywood padded with polyurethane. Wooden slats supported by four corner elements and a central bar, adjustable in height, in lacquered steel. All the storage compartments are equipped with LED lights. Metal parts available in the metal finishing selection. Shown with bed linings, pillows and bedcover: Secret.

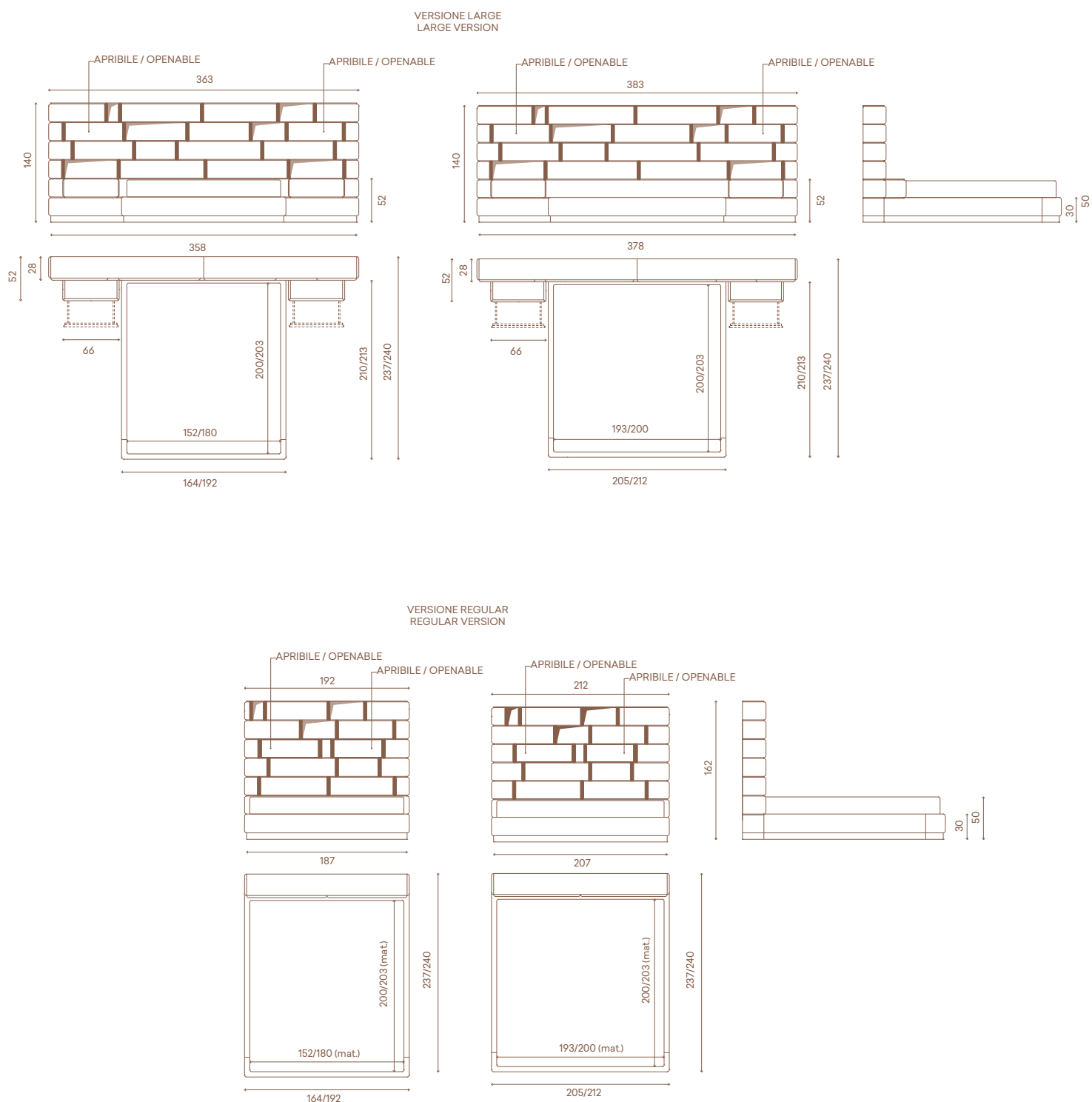

# ERCOLANO

Tappeto da esterno  
Outdoor carpet

Design  
La Conca

Tappeto taftato a mano in polipropilene. Backing in cotone.  
Hand-tufted carpet in polypropylene. Cotton backing.

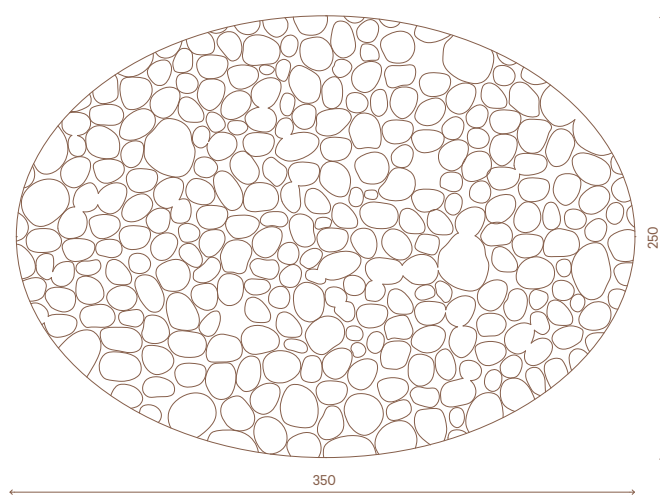

# ETHAN

Applique  
Wall lamp

Design  
Alessandro La Spada

Applique a colonna in vetro. Struttura portante in acciaio e ottone satinato, finitura cromo o oro, con spigoli sfaccettati e superfici laterali in vetro rigato. Corpi illuminanti a LED a luce calda integrati nel telaio. Piastra di attacco a parete in acciaio rivestito in specchio, assorbimento 20W, peso 16 kg.

Column-shaped wall lamp. Main structure in steel and satinized brass, chrome or gold finishing, with multi-faceted edges and sides in grooved glass. Warmlight LED bars integrated in the structure. Plate for wall-fixing, coated in mirror, max 20W in total, weight 16 kg.

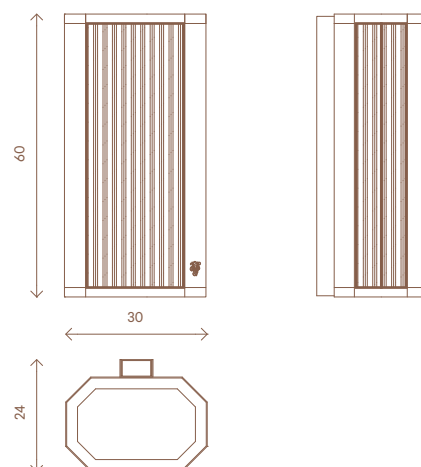

# ETHAN

Lampadario  
Chandelier

Design  
Alessandro La Spada

Lampadario in vetro su tre livelli. Struttura portante in acciaio e ottone satinato, finitura cromo o oro, con spigoli sfaccettati e superfici laterali in vetro rigato. Corpi illuminanti a LED a luce calda integrati nel telaio. Rosone a soffitto in acciaio satinato con sospensioni regolabili in cavo d'acciaio, assorbimento 220W, peso 90 kg.

Chandelier in glass disposed on 3 levels. Main structure in steel and satinized brass, chrome or gold finishing, with faceted edges and sides in grooved glass. Warmlight LED bars integrated in the structure. Ceiling cup in satinized steel with adjustable suspension in steel wire cable, max 220W in total, weight 90 kg.

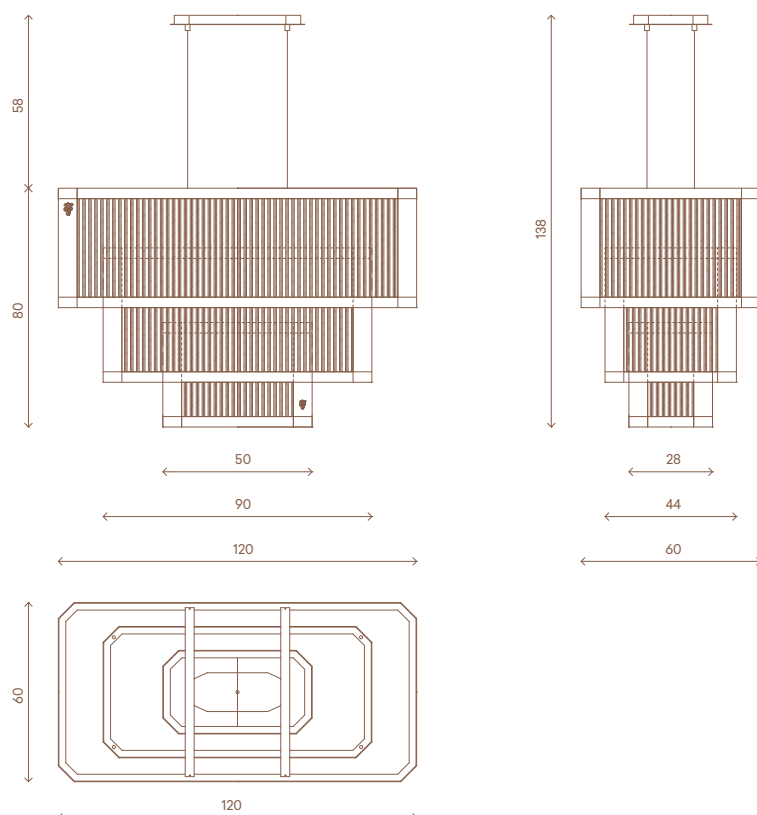

# ETHAN

Lampadario  
Chandelier

Design  
Alessandro La Spada

Lampadario in vetro su tre livelli sovrapposti a diametro decrescente. Telaio in acciaio satinato e corpo centrale composto da un tamburo di canne in vetro pirex trasparente, sospesi con cavi in acciaio regolabili in altezza (H. max 3,40 mt). Impianto luci con 6 sorgenti LED max 240W dimmerabile, peso 90 kg.

*Chandelier in glass on three levels in decreasing diameter. Frame in satinized steel and central main body made of tubes of transparent pyrex, hung with adjustable steel wires (maximum height 3,40 lm). Dimmable lighting system with 6 LED lights max 240W, weight 90 kg.*

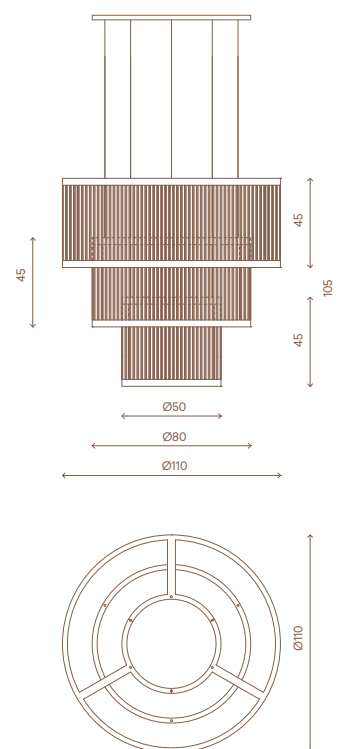

# EUCLIDE

Lampada da tavolo  
Table lamp

Design  
La Conca

Lampada da tavolo interamente in marmo, con diffusore interno in onice bianco. Sorgente luminosa a LED. Disponibile con corpo in marmo Calacatta oro oppure bianco di Carrara, arabescato, nero marquina, grafite, Emperador e verde Guatemala.

*Table lamp in marble, with internal diffuser in white onyx. LED lighting system. Available in: Calacatta gold, white Carrara, Arabescato, Black Marquina, Grafite, Emperador and Green Guatemala.*

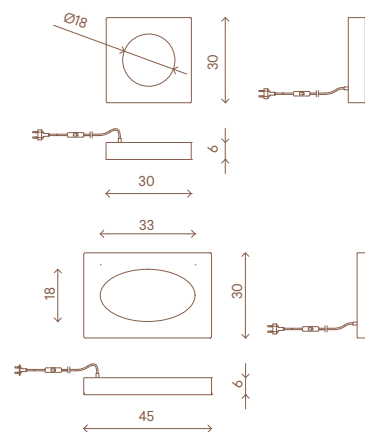

# FLOYD

Piantana  
Floor lamp

Design  
Giuseppe Viganò

Struttura in acciaio satinato, diffusore in vetro offiato disponibile nelle finiture acqua/ latte, acqua/ambra o tartaruga, impianto luci a LED dimmerabile 40W.

*Structure in satinized steel, diffuser in blown glass available in the following finishes: water/milk, water/amber or turtle pattern. Dimmable LED lighting system, max 40W.*

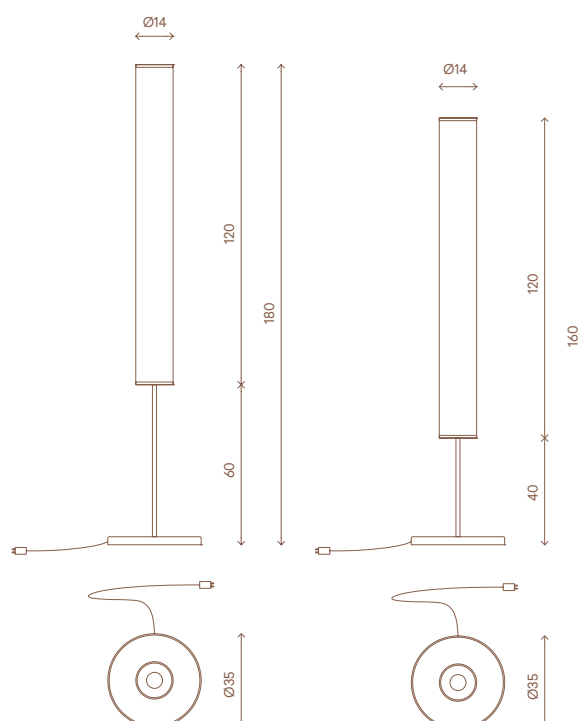

# GAIUS

Mobile bar  
Bar cabinet

Design  
Giuseppe Viganò

Mobile bar in cristallo fumé sp.8 mm scatola tramite saldature UV con box interno in legno interamente rivestito in essenza con apertura a ribalta con meccanismo smorzato. Ante in cristallo con maniglie a pendaglio e cerniere in ottone satinato. Stelo di sostegno in metallo rivestito in essenza e base in acciaio inox satinato. Le parti in legno sono disponibili nelle finiture selezione essenze, le parti metalliche sono disponibili nella selezione finiture metalliche. Disponibile con illuminazione interna a LED con cavo di alimentazione sotto la base.

*Bar cabinet in smoked crystal th.8 mm boxed by UV bonding with internal wooden box completely veneered, with flap opening with damped mechanism. Crystal doors with frosted brass hinges and pendant handles. Support stem in veneered metal and base in brushed stainless steel. Wooden parts available in the veneer finishings selection, metal parts available in the metal finishing selection. Available with LED interior lighting with power cable under the base.*

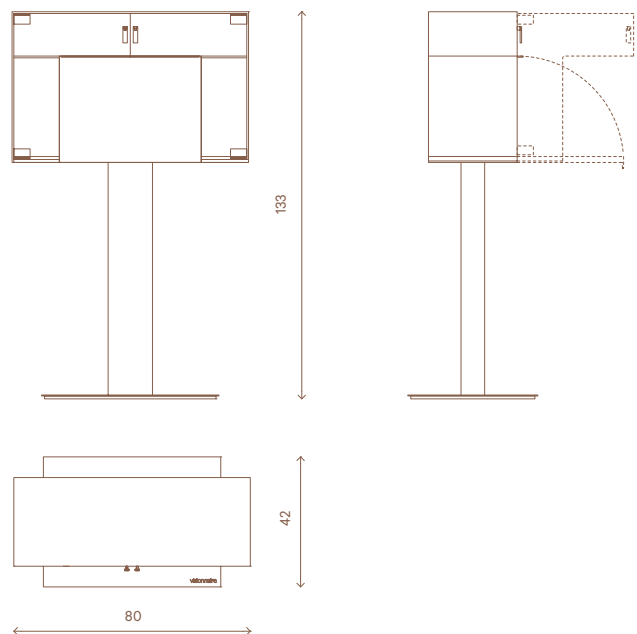

# GALDOR

Specchio  
Mirror

Design  
Armando Bruno

Specchio in marmo e vetro accostati a filo, cornice in acciaio satinato. Marmi intarsiati in diverse combinazioni cromatiche. Il sistema di attacco prevede diverse possibilità di orientamento. I marmi sono intarsiati a strisce di Nero Marquina, Arabescato Vagli e Grigio Bardiglio. Le parti in acciaio sono disponibili nella selezione finiture metalliche satinate.

*Mirror in marble and glass, frame in thin satinized stainless steel. Marbles inlaid in different colour combinations. The attachment system provides various possibilities of orientation. The marbles are inlaid with strips of Nero Marquina, Arabescato Vagli and Grigio Bardiglio. Metal parts available in the satinized metal finishing selection.*

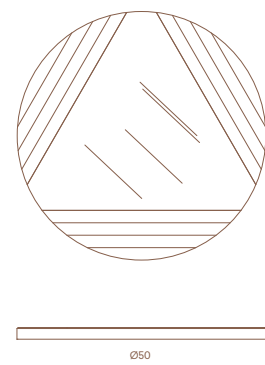

# GALAHAD

Lampadario  
Chandelier

Design  
Philippe Montels

Lampadario a sospensione in scaglie di alluminio naturale o champagne montate su struttura in acciaio galvanizzato.

*Ceiling lamp in aluminium armour-plate or champagne plate put on a galvanized steel frame.*

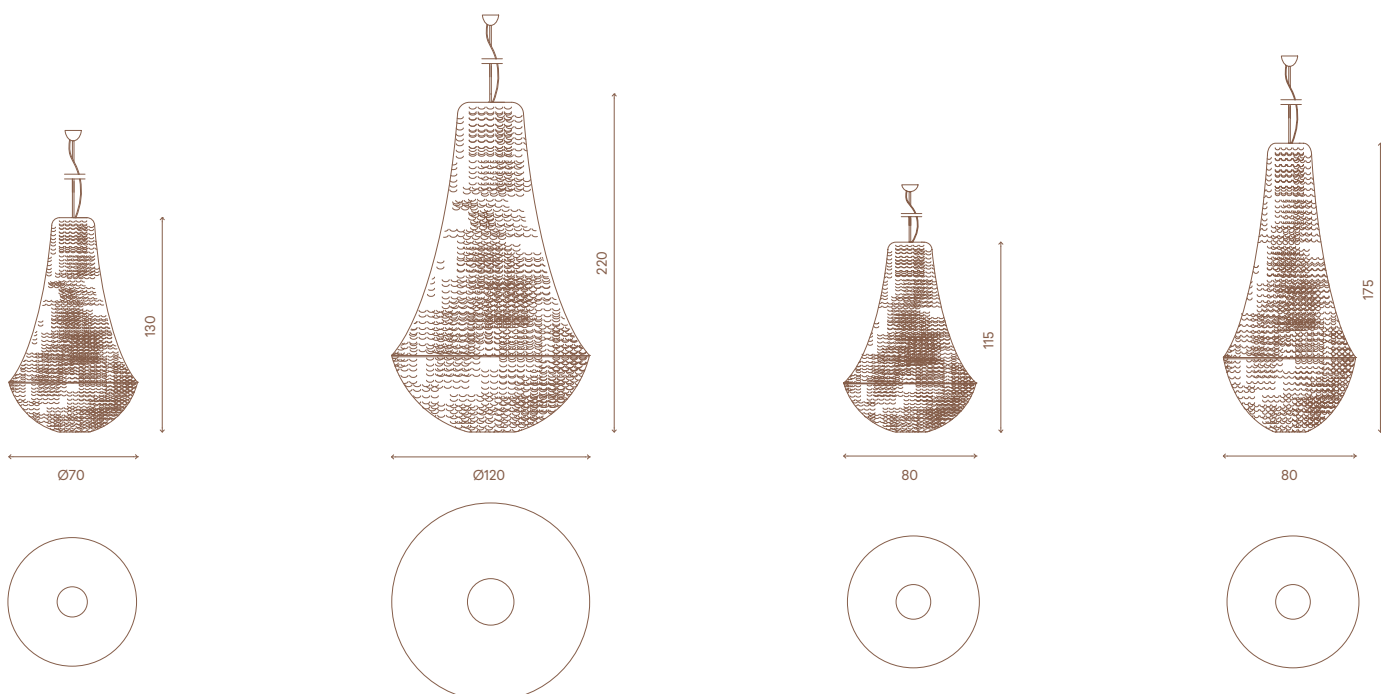



# GAYNOR

**Libreria**  
**Bookshelf**

**Design**  
Alessandro La Spada

Libreria componibile con moduli da 40, 60 e 160 cm, H. 250 cm; spalle in MDF completamente rivestite in essenza; mensole e pannello di fondo in MDF rivestito in pelle o tessuto. 8 cassetti e 10 ante rivestiti in pelle o tessuto. Profilature, fregi e base in acciaio satinato. Interno dei vani e dei cassetti in MDF laccato opaco. Le parti in metallo sono disponibili nelle finiture cromo, oro, champagne, bronzo, Siena, nickel nero, canna di fucile.

Modular bookshelf with modules of 40/60 and 160 cm, H. 250 cm; internal and external vertical panels in veneered wood; shelves and bottom panels in MDF upholstered in leather or fabric. 8 drawers and 10 doors upholstered in leather or fabric. Profiles, ornaments and plinth in satinized steel. Inside of the units and drawers in matt lacquered MDF. Metal parts available in chrome, gold, champagne, bronze, Siena, black nickel and gunmetal finishing.

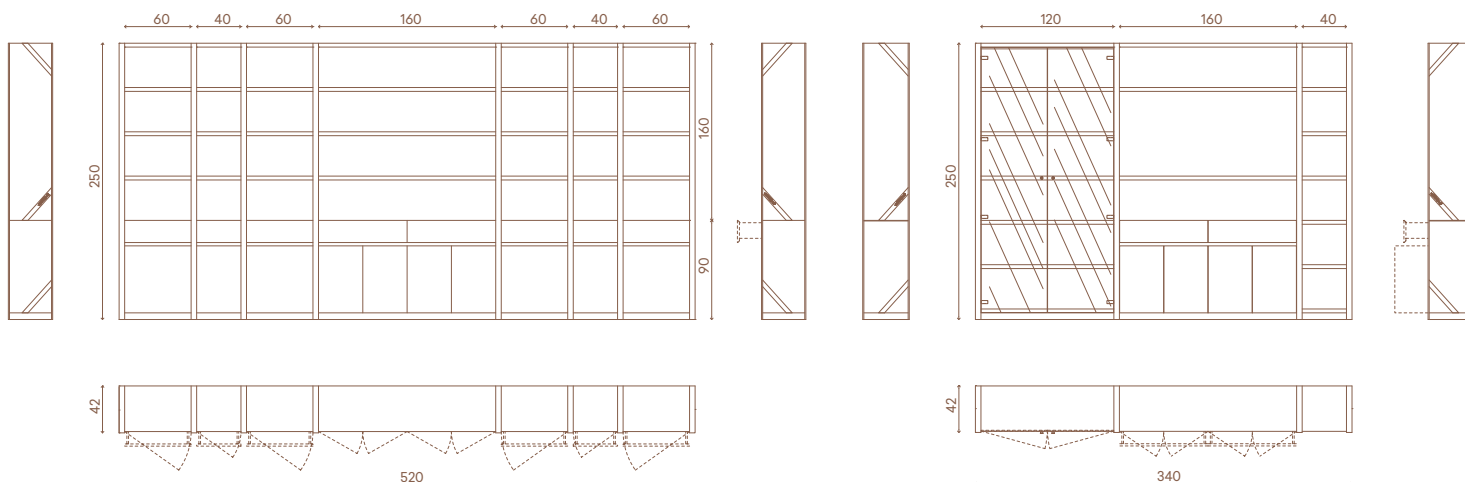

# HAMMOND

**Plafoniera**  
**Ceiling lamp**

**Design**  
Roberto Tapinassi - Maurizio Manzoni

Plafoniera a 21 luci G9 max 28 watt cad. Assorbimento totale 588 watt. Struttura acciaio e ottone placcato oro 24k. 22 grappoli di pendenti tubolari in vetro borosilicato colorato oro. Peso kg 90.

Ceiling light, 21 cluster lights G9 max 28 watt each. Total power consumption 588 watt. Structure in stainless steel and brass plated 24k gold. 22 cluster pendants in tubular borosilicate glass golden coloured. Weight kg 90.

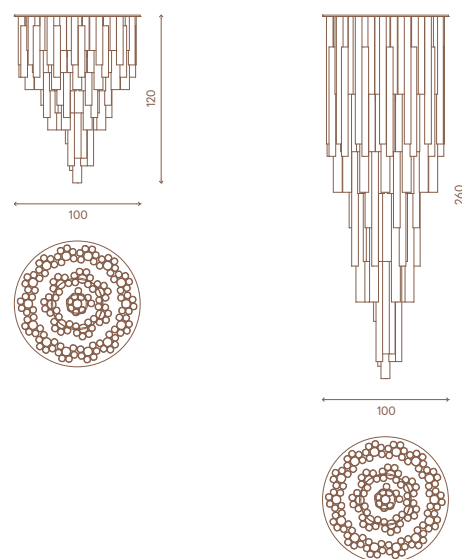

# HARMONY

**Porta asciugamani**  
**Towel holder**

**Design**  
Alessandro La Spada

Struttura in acciaio inox satinato con piano d'appoggio in marmo. Le parti metalliche sono disponibili nella selezione finiture metalliche satinato.

Structure in satinized stainless steel with support surface in marble. Metal parts available in the satinized metal finishing selection.

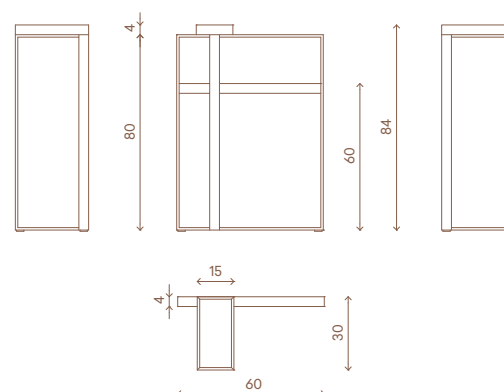

# HARMONY

Appendiabiti da parete  
*Clothes hanger*

Design  
Alessandro La Spada

Cornice in acciaio inox satinato con inserto in marmo. Le parti metalliche sono disponibili nella selezione finiture metalliche satiniate.

*Frame in satinized stainless steel with marble insert. Metal parts available in the satinized metal finishing selection.*

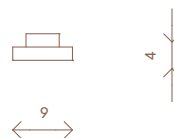

# HARMONY

Mobile porta lavabo singolo, specchiera  
*Console with single basin, mirror*

Design  
Alessandro La Spada

Struttura in legno multistrati marino con cestoni e sponde in vetro/acciaio a guide smorzate. Cassetto interno in legno laccato opaco, frontale e fianchi in marmo lavorato per incisione in bassorilievo con disegno geometrico e bordi superiori rivestiti in acciaio inox satinato. Piedi in acciaio inox satinato. Lavello in marmo scolpito dal massello in pezzo unico. Rubinetteria disponibile nelle finiture cromo, bronzo e nickel nero lucidi, canna di fucile patinato e Siena satinato. Specchiera con inserto in marmo ed inserto in acciaio inox satinato con logo Visionnaire inciso, bordi esterni in acciaio inox satinato. Disponibile anche in versione pensile. Le parti metalliche sono disponibili nella selezione finiture metalliche satiniate.

*Structure in marine plywood panels with basket drawers and sides in glass/steel with damped rails. Internal drawer in mat lacquered wood, front and sides in marble with geometric pattern in basrelief engraving and upper borders covered with satinized stainless steel. Feet in satinized stainless steel. Basin in marble obtained from solid marble in one single piece. Taps available in: shiny chrome, shiny bronze, shiny black nickel, patinated gunmetal, satinized Siena. Mirror with insert in marble and insert in satinized stainless steel with engraved Visionnaire logo, external borders in satinized stainless steel. Available also in wallmounted version. Metal parts available in the metal finishing selection.*

VERSIONE PENSILE  
WALL MOUNTED VERSION

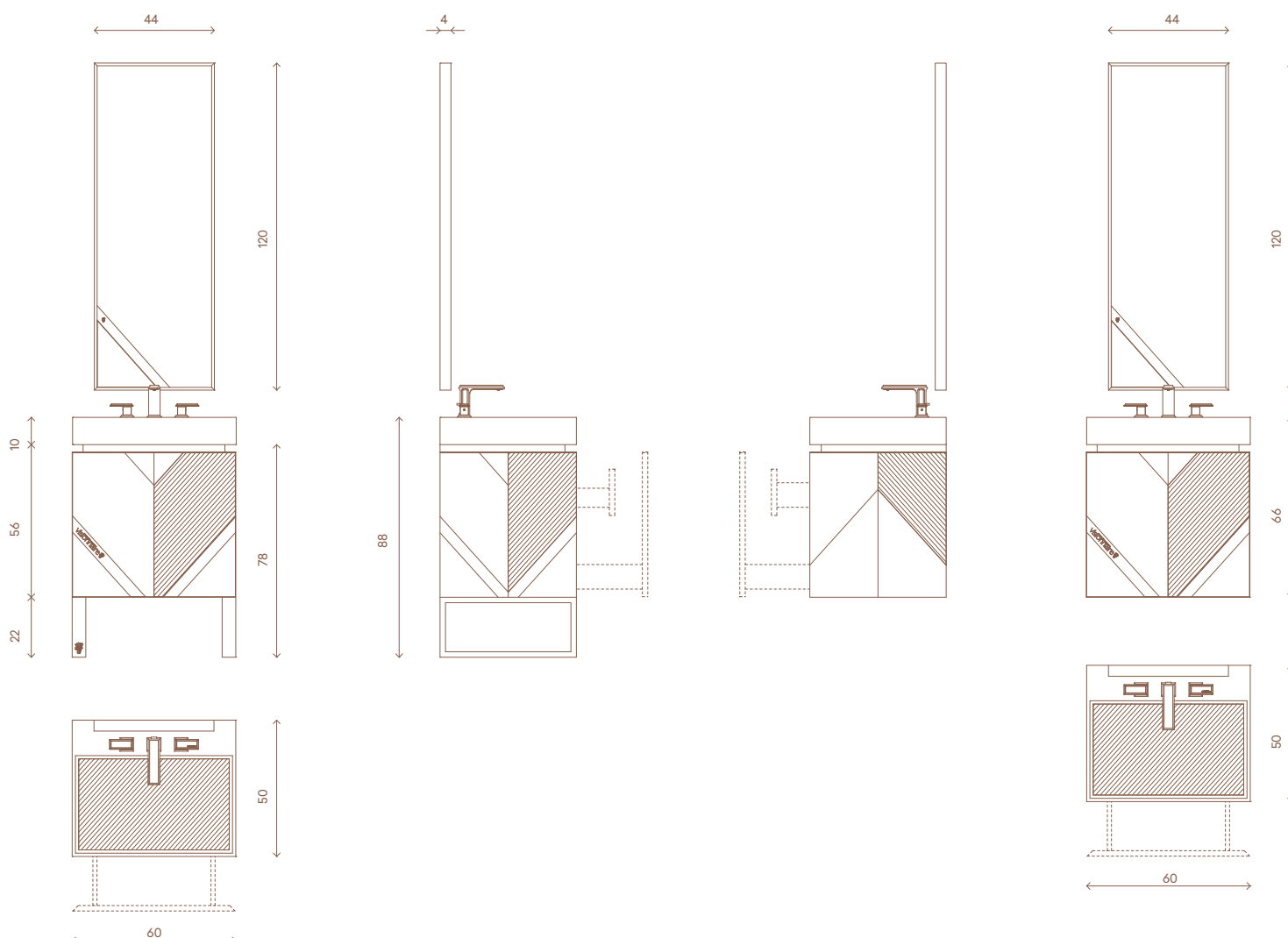

# HARMONY

**Mobile porta lavabo - singolo e doppio**  
**Console with basin - single and double**

**Design**  
 Alessandro La Spada

Struttura in legno multistrati marino con cestoni e sponde in vetro/acciaio a guide smorzate. Cassetti interni in legno laccato opaco, frontali e fianchi in marmo lavorato per incisione in bassorilievo con disegno geometrico e bordi superiori rivestiti in acciaio inox satinato. Piedi in acciaio inox satinato. Top e lavello in marmo scolpito dal massello in pezzo unico. Rubinetteria disponibile nelle finiture cromo, bronzo e nickel nero lucidi, canna di fucile patinato e Siena satinato. Specchiera con inserto in marmo e acciaio inox satinato con logo Visionnaire inciso, bordi esterni in acciaio inox satinato. Le parti metalliche sono disponibili nella selezione finiture metalliche satinate.

Structure in marine plywood panels with basket drawers and sides in glass/steel with damped rails. Internal drawers in mat lacquered wood, front and sides in marble with geometric pattern in bas-relief engraving and upper borders covered with satinized stainless steel. Feet in satinized stainless steel. Top and basin in marble obtained from solid marble in one single piece. Taps available in: shiny chrome, shiny bronze, shiny black nickel, patinated gunmetal, satinized Siena. Mirror with insert in marble and satinized stainless steel with engraved Visionnaire logo, external borders in satinized stainless steel. Metal parts available in the satinized metal finishing selection.

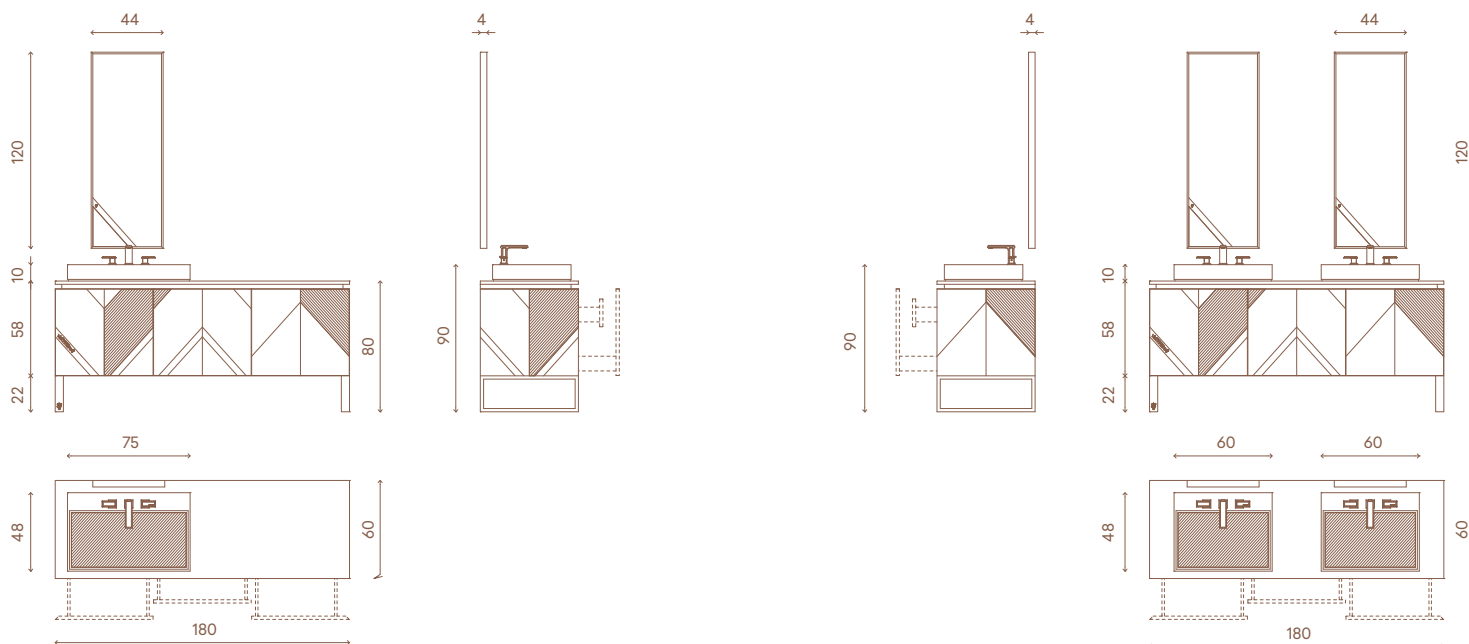

# HYPERION

**Tappeto**  
**Carpet**

**Design**  
 Alessandro La Spada

Tappeto taftato a mano in bamboo silk e lana New Zealand con lavorazione carving manuale. Placca in ottone ovale con incisione logo Visionnaire. Backing in cotone.

Hand-tufted carpet in bamboo silk and New Zealand wool with carving work. Metal insert with Visionnaire logo engraved in bas-relief. Cotton backing.

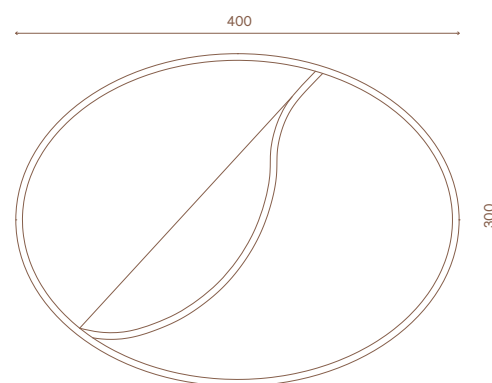

# JABBA

**Lampadario**  
**Chandelier**

**Design**  
 Philippe Montels - La Conca

Lampadario ellittico, formato da un grande drappo in scaglie in alluminio naturale o anodizzato oro. Struttura portante in acciaio con pannello portafaretti. 8 luci GU10 max 50 watt cad. assorbimento totale max 400 watt. Peso kg 36.

Elliptical chandelier, composed of a large drape in natural or anodized gold aluminium scales. Main steel structure with spotlights door panel in steel. 8 lights GU10 max 50 watt each. (max 400 Watt total). Weight kg 36.

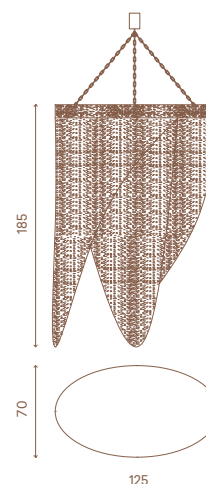

# JASON

## Tavolo da pranzo Dining table

Design  
Roberto Lazzeroni

Tavolo da pranzo tondo con top in marmo composto da un macro-mosaico in tre tipologie di marmo intarsiate con profilo metallico da 5 mm in acciaio inox lavorato a filo del piano. Il bordo del top è lavorato con profilo smussato. Sottotop in legno laccato lucido a sezione smussata. Basamento composto da tre gambe concave in legno rivestito in cuoio nero con profili decorativi in acciaio inox satinato e traversi centrali. Disponibile con "lazy susan" incassato a filo del top oppure con "lazy susan" in appoggio asportabile. Le parti in metallo del basamento sono disponibili nella selezione finiture metalliche.

Round dining table with marble top composed of a macro-mosaic in three types of marble inlaid with a 5 mm metal profile in stainless steel. The edge of the top is worked with a rounded edge. Undermount in glossy lacquered wood with rounded section. Base made of three concave wooden legs covered in black leather with decorative profiles in stainless steel. Available with turning "Lazy Susan" built in the top or removable leaned on it. The metal parts of the base are available in the metal finishing selection.

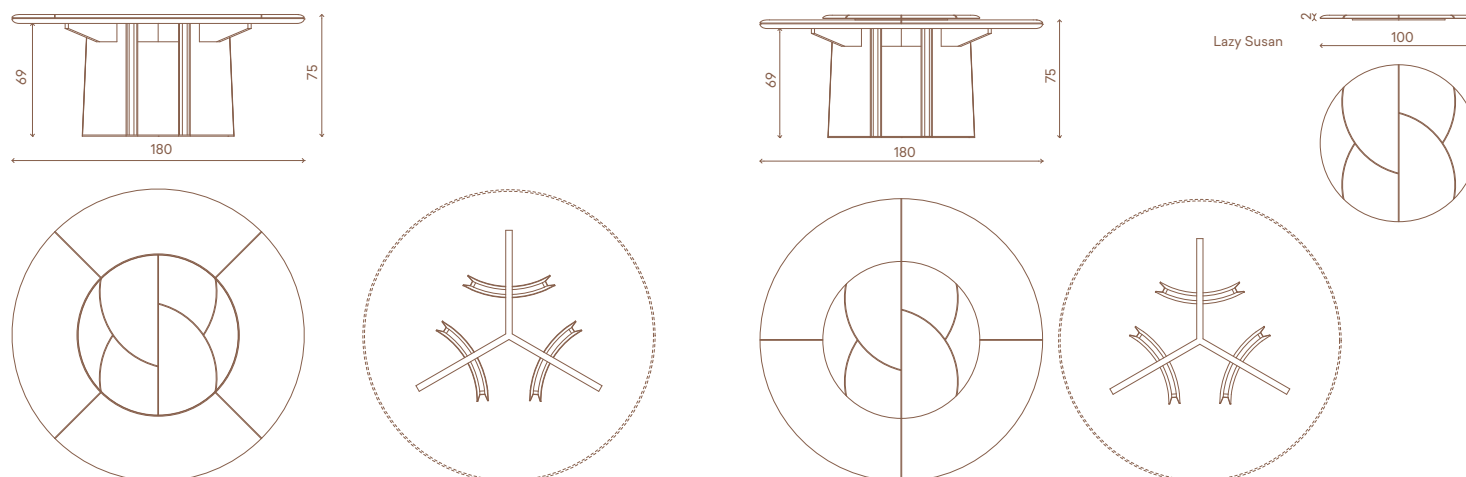

# JASON

## Tavolo da pranzo Dining table

Design  
Roberto Lazzeroni

Tavolo da pranzo ovale con top in marmo composto da un macro-mosaico in tre tipologie di marmo intarsiate con profilo metallico da 5 mm in acciaio inox lavorato a filo del piano. Il bordo del top è lavorato con profilo smussato. Sottotop in legno laccato lucido a sezione smussata. Basamento composto da due gambe concave in legno rivestito in cuoio nero con profili decorativi in acciaio inox satinato e traverso centrale. Le parti in metallo del basamento sono disponibili nella selezione finiture metalliche.

Oval dining table with marble top composed of a macro-mosaic in three types of marble inlaid with a 5 mm metal profile in stainless steel. The edge of the top is worked with a rounded edge. Undermount in glossy lacquered wood with rounded section. Base made of two concave wooden legs covered in black leather with decorative profiles in stainless steel. The metal parts of the base are available in the metal finishing selection.

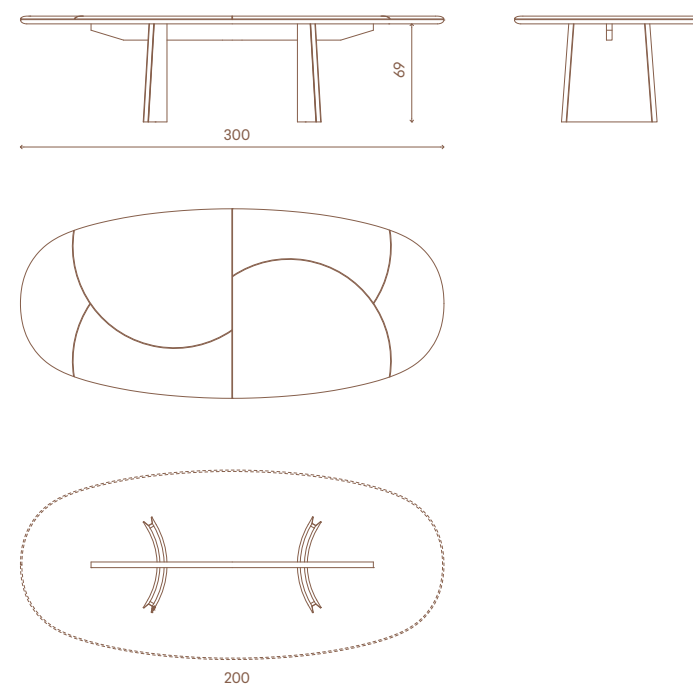

# JASPER

Lampada da tavolo  
Table lamp

Design  
Fabio Bonfà

Lampada da tavolo in ottone massiccio e marmo. Proiettore lineare in ottone contenente una sorgente LED dimmerabile a luce calda da 6W, stelo composto da un doppio tubo di ottone e un elemento conico in marmo massello, base in acciaio satinato. Le parti metalliche sono disponibili nella selezione finiture metalliche satiniate.

*Table lamp in solid brass and marble. Linear brass projector containing a 6W dimmable LED warm light source, stem consisting of a double brass tube and a conical solid marble element, base in satinized steel. Metal parts available in the satinized metal finishing selection.*

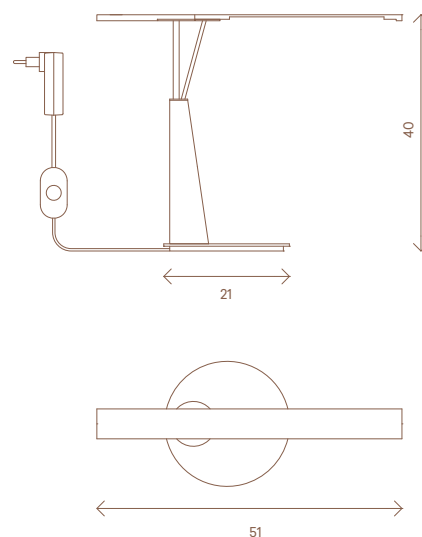

# JERA

Sedia imbottita  
Padded chair

Design  
Steve Leung

Struttura in legno massello laccato lucido (colori RAL). Torneria retro-schienale e puntali in alluminio cromato, scocca in multistrati curvato rivestita all'esterno in pelle o tessuto, imbottita all'interno in poliuretano e tappezzata in pelle o tessuto, con lavorazione trapuntata. Opzione parti metalliche in finitura laccata bronzo o oro.

*Structure in solid natural wood with shiny lacquered finishing (RAL colours). Turning on rear backrest and tips in chromed aluminium, curved plywood frame covered in fabric or leather on the outside; inside in polyurethane padding, upholstered in fabric or leather with quilted finishing. Option: metal parts lacquered in bronze or in gold finishing.*

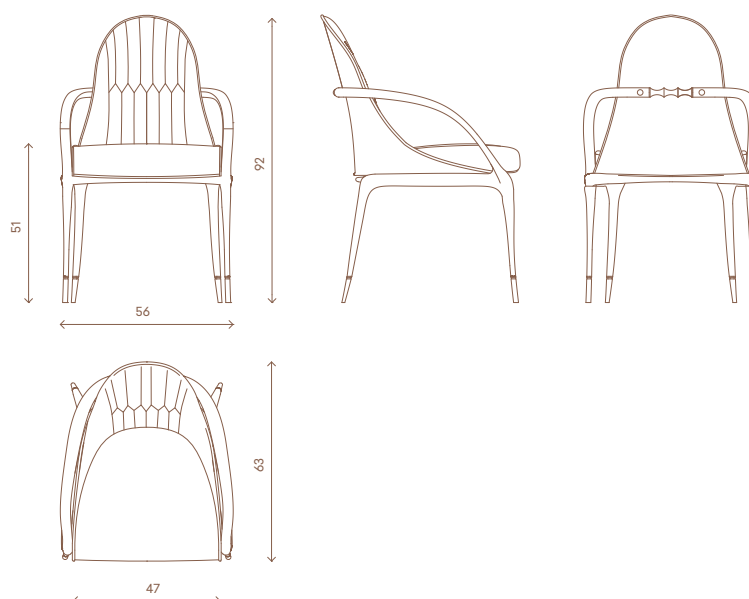

# JORGE

Panca  
Bench

Design  
La Conca

Cassapanca imbottita rivestita in pelle o tessuto, con sedile apribile disponibile in pelle o tessuto intrecciato. Fusto interno in legno, base e profilo sedile in acciaio inox satinato. Vano interno in legno laccato. Le parti metalliche sono disponibili nella selezione finiture metalliche.

*Upholstered chest covered in leather or fabric, with opening seat available in leather or woven fabric. Internal wooden frame, base and seat profile in brushed stainless steel. Internal compartment in lacquered wood. Metal parts available in the metal finishing selection.*

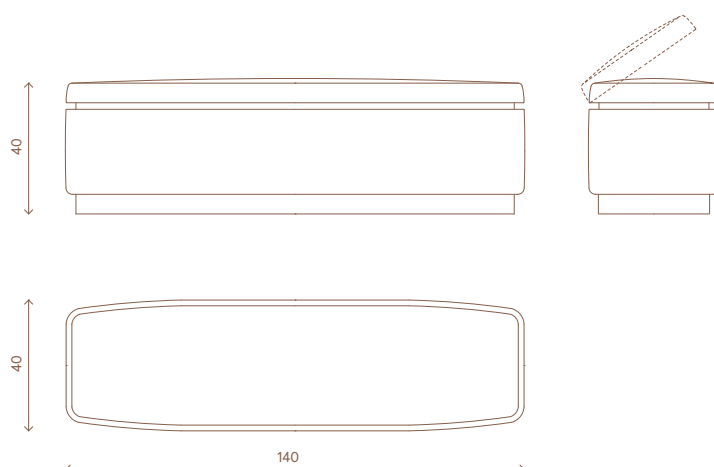

# KALGAN, BILBO, KAEL BOREAL

Lampade a sospensione  
*Suspension lamp*

Design  
Marco Piva

Lampade a sospensione in vetro con trattamento superficiale di vaporizzazione metallica di ottone antico, titanio sfumato e rame brunito. Sorgente luminosa a LED – COB 9W con diffusore interno in pirex satinato. Disponibili singolarmente e come plafoniere da tre e nove elementi con piastra metallica a soffitto e cavi regolabili in altezza.

*Suspension lamps in glass with surface treatment of metal vaporization of antique brass, titanium fade and dark copper. LED – COB 9W light source with internal diffuser in satin Pyrex. Available individually or as ceiling lights of three and nine elements with metal ceiling plate and height-adjustable cables.*

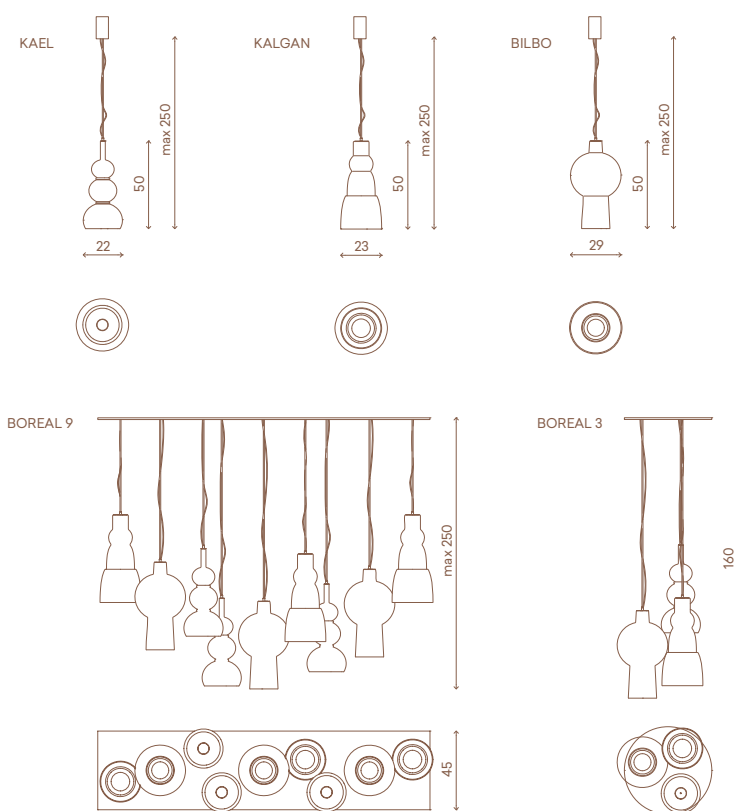

# KATHRYN

Divano  
*Sofa*

Design  
Giuseppe Viganò

Divano outdoor, struttura di base in multistrati marino curvato rivestito teak contenente un cuscino di seduta in poliuretano espanso in diverse densità, imbottito e rivestito in tessuto o pelle da esterno. Schienale curvo formato da struttura in ottone e acciaio inox, intrecciata in corda di lino grezzo e bacchette di teak massello. Stemma decorativo sui braccioli con nappe in cuoio e ottone. Cuscino volante per lo schienale in fiocco acrilico in pelle o tessuto da esterno.

*Outdoor sofa, base structure in curved marine plywood covered with teak containing a seat cushion in polyurethane foam in different densities, upholstered in fabric or leather for outdoor use. Curved backrest made of brass and stainless steel structure, woven with natural linen rope and solid teak rods. Decorative coat of arms on the armrests with leather and brass tassels. Loose cushion for the back in acrylic flakes, in leather or outdoor fabric.*

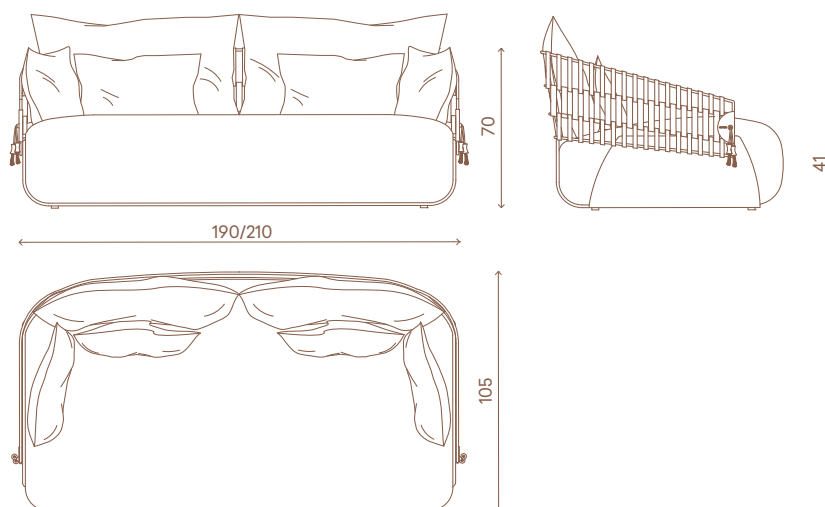

# KATHRYN

Lampada outdoor  
*Outdoor lamp*

Design  
Giuseppe Viganò

Lampada da terra outdoor, struttura in multistrati marino curvato rivestito teak contenente una sfera luminosa in polietilene con grado di isolamento IP55, portalamпада E27 max 25W, cavo di alimentazione con spina isolata SENZA interruttore.

*Outdoor floor lamp, structure in curved marine plywood covered in teak containing a luminous sphere in polyethylene with IP55 insulation degree, E27 lampholder max 25W, power cord with insulated plug WITHOUT switch.*

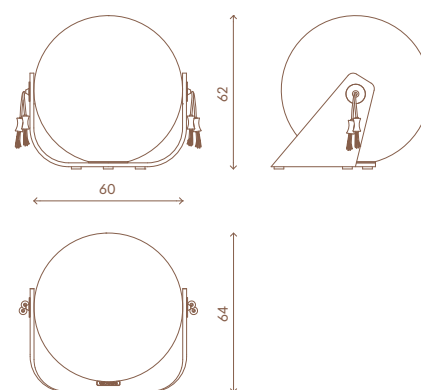

# KATHRYN

## Poltroncina e Pouf Armchair and pouffe

Design  
Giuseppe Viganò

Poltroncina outdoor, struttura di base in multistrati marino curvato rivestito teak contenente un cuscino di seduta in poliuretano espanso in diverse densità, imbottito e rivestito in tessuto o pelle da esterno. Schienale curvo formato da struttura in ottone e acciaio inox, intrecciata in corda di lino grezzo e bacchette di teak massello. Stemma decorativo sui braccioli con nappe in cuoio e ottone. Cuscino volante per lo schienale in fiocco acrilico in pelle o tessuto da esterno.

*Outdoor armchair, base structure in curved marine plywood covered with teak containing a seat cushion in polyurethane foam in different densities, upholstered in fabric or leather for outdoor use. Curved backrest made of brass and stainless steel structure, woven with natural linen rope and solid teak rods. Decorative coat of arms on the armrests with leather and brass tassels. Loose cushion for the back in acrylic flakes, in leather or outdoor fabric.*

Pouf outdoor, struttura di base in multistrati marino curvato rivestito teak contenente un cuscino di seduta in poliuretano espanso in diverse densità, imbottito in tessuto o pelle da esterno.

*Outdoor pouffe, base structure in curved marine plywood covered with teak containing a seat cushion in polyurethane foam in different densities, upholstered in fabric or leather for outdoor use.*

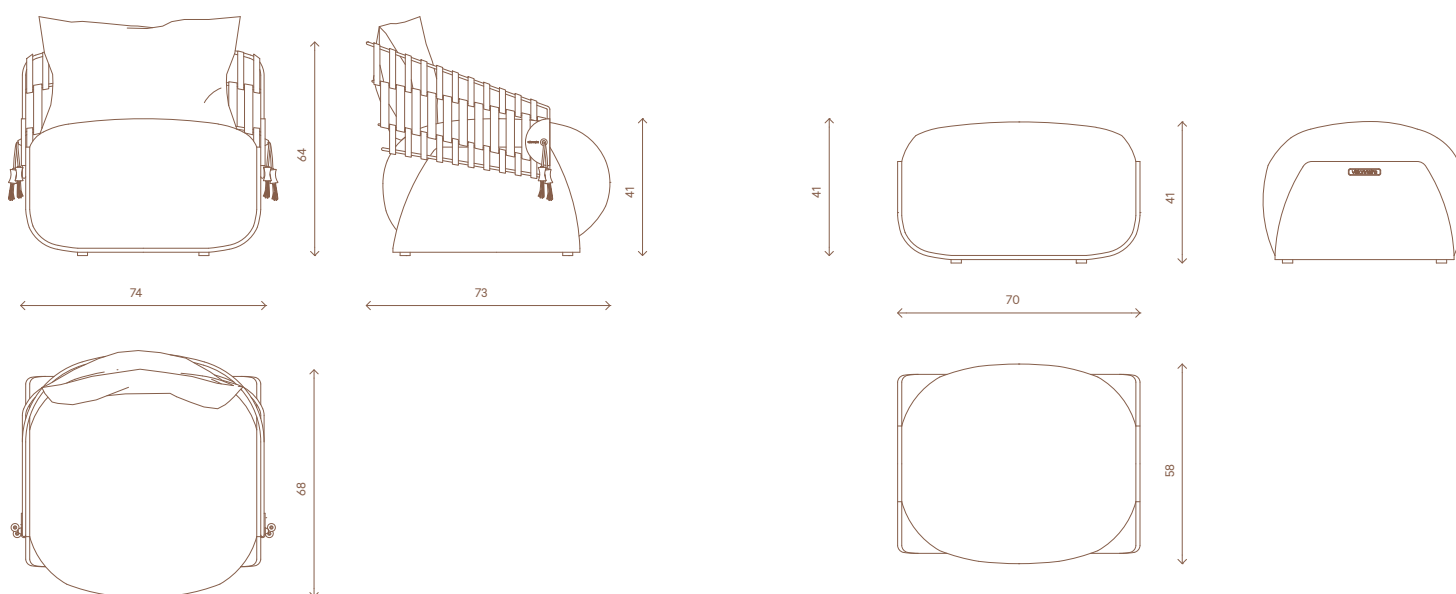

# KENAZ

## Tavolino basso Low table

Design  
Steve Leung

Stelo in fusione di alluminio satinato sagomato a forma di chiocciola, sottotop in legno laccato lucido e top in marmo o semiprezioso a incasso. Stelo disponibile in finitura satinata oro, bronzo o argento.

*Base in snail shaped satinized aluminium cast. Under top in polish lacquered wood and top in marble or semiprecious stone. The base is also available in mat gold, bronze or silver colours.*

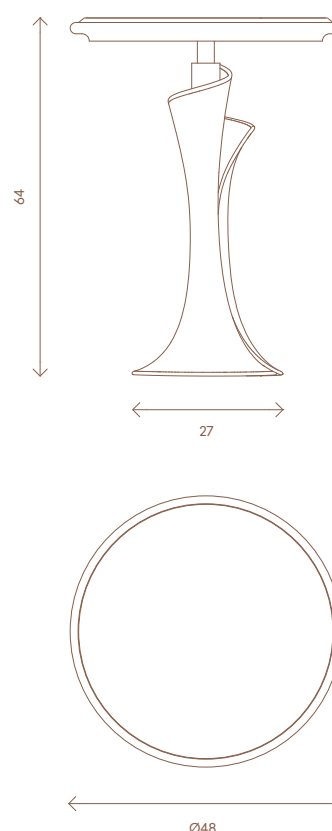

# KERWAN

Tavolo da pranzo  
*Dining table*

Design  
Alessandro La Spada

Tavolo da pranzo, top in lastra di marmo con bordo bisellato in negativo e sottotop in legno laccato. Basamento in acciaio inox lucido curvato su tre lati. Le superfici esterne concave del basamento sono realizzate in marmo curvato e lucidato. Le parti in acciaio sono disponibili nella selezione finiture metalliche. Disponibile anche nella versione in essenza con top e superfici concave in legno rivestito nei materiali della selezione essenze.

*Dining table, top in marble with bevelled edge and under board in lacquered wood. Polished and curved stainless steel base with concave external surfaces made of curved and polished marble. Metal parts available in the metal finishing selection. Also available in the veneer version with top and concave wooden surfaces coated in the materials of the veneer selection finishings.*

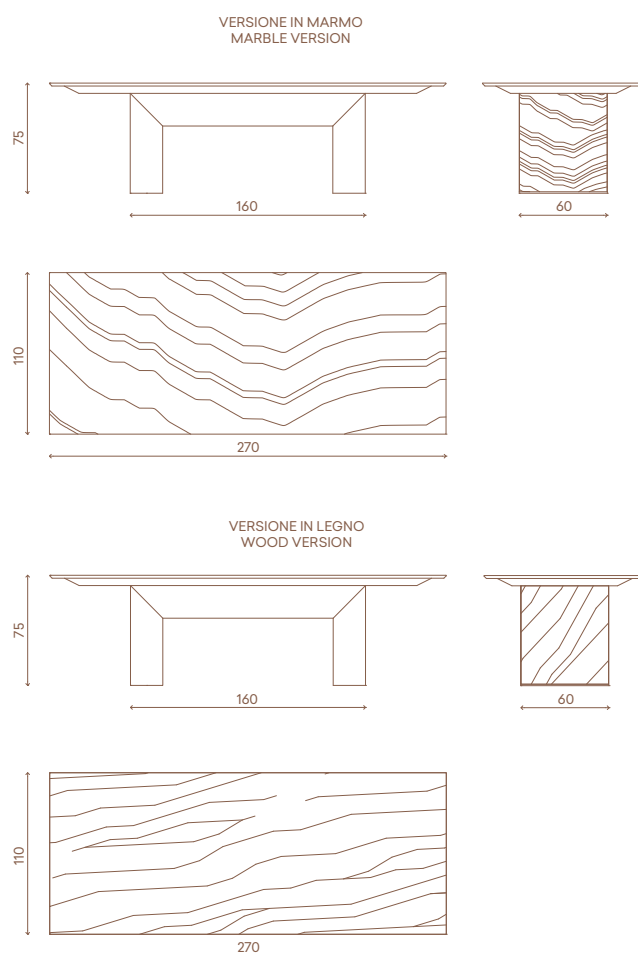

# KOBOL

Accessori bagno  
*Accessories*

Design  
Alessandro La Spada

Linea di accessori in ceramica rigata con dettagli in acciaio inox e ottone satinato, composta da bicchiere quadrato, dispenser sapone, contenitore rettangolare con coperchio e con griglia.

*Line of accessories in striped ceramic with details in stainless steel and satin brass, composed of square box, soap dispenser, rectangular container with lid and with grill.*

SCATOLA MULTIUSO  
MULTIPURPOSE BOX

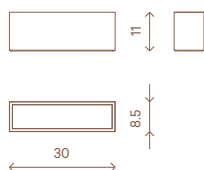

SCATOLA SINGOLA  
SINGLE BOX

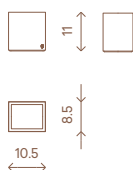

COVER GRANDE  
COVER "BIG"

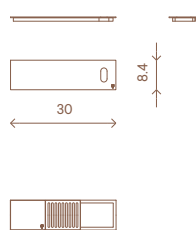

COVER PICCOLA  
COVER "SMALL"

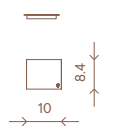

COVER SAPONE  
SOAP COVER

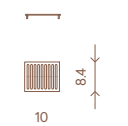

CONTENITORE SAPONE  
SOAP DISPENSER

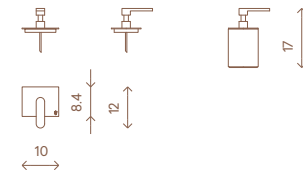

# KOBOL

Specchio  
*Mirror*

Design  
Alessandro La Spada

Specchio a posizionamento verticale con bordo molato e schienale in legno nero. Tre elementi decorativi in ottone satinato lungo il perimetro.

*Vertical mirror with ground edge and black wood back. Three decorative elements in satin brass along the perimeter.*

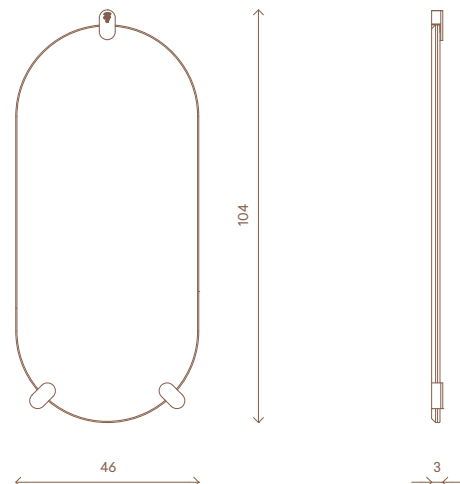



# KOBOL

## Consolle lavabo singolo Console with single washbasin

Design  
Alessandro La Spada

Consolle da toilette con lavabo singolo, mobile in legno con un cassetto provvisto di alzata laterale e posteriore in legno massello scolpito in bassorilievo con lavorazione "canneté", internamente rivestita in acciaio inox satinato. Top in marmo sciolto con parte posteriore rialzata a supporto della rubinetteria. I rubinetti ed erogatore dell'acqua sono realizzati in ottone massiccio cromato. Lavabo in ceramica smaltata con esterno bianco oppure smaltato oro o platino, provvisto di piatto copri scarico in ceramica. Struttura portante in acciaio inox satinato, provvista di ripiano porta salviette in vetro o marmo. Predisposto per fissaggio a parete. Le parti in legno sono disponibili anche in finitura laccata lucida. Le parti in metallo sono disponibili nella selezione finiture metalliche. Compatibile con linea accessori bagno Kobol.

*Console with a single washbasin, wooden cabinet with one drawer with side and back in solid wood carved in bas-relief with "canneté" processing, internally covered in satin stainless steel. Boxed marble top with raised rear part to support the taps. The faucets and the knobs are made of solid chromed brass. Glazed ceramic washbasin with white, gold or platinum enamelled exterior, provided with ceramic drain plate. Structure in brushed stainless steel, equipped with glass or marble towel shelf. Prepared for wall mounting. Wooden parts are also available in polished lacquered finish. Metal parts available in the metal finishing selection. Compatible with Kobol bathroom accessories line.*

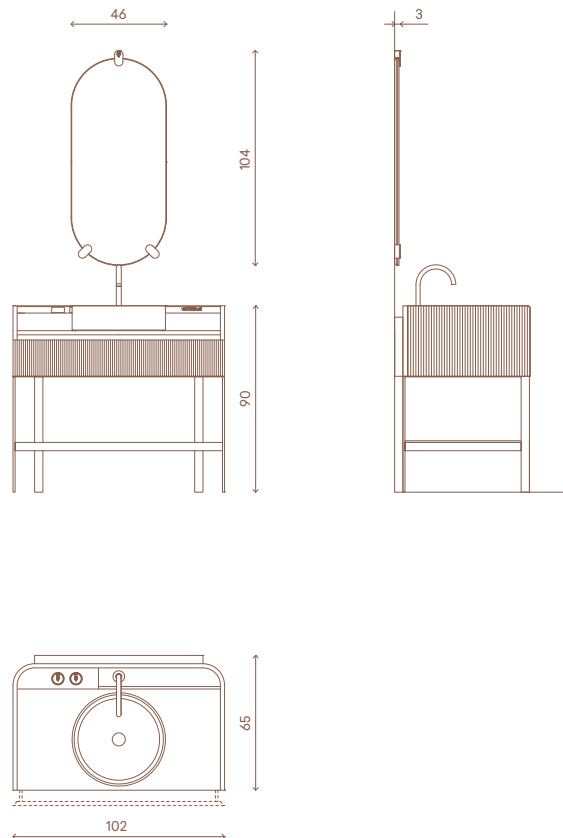

# KOBOL

## Consolle lavabo doppio Console with two washbasins

Design  
Alessandro La Spada

Consolle da toilette con due lavabi, mobile in legno con due cassetti provvisti di alzata laterale e posteriore in legno massello scolpito in bassorilievo con lavorazione "canneté", internamente rivestita in acciaio inox satinato. Top in marmo sciolto con parte posteriore rialzata a supporto della rubinetteria. I rubinetti ed erogatore dell'acqua sono realizzati in ottone massiccio cromato. Lavabo in ceramica smaltata con esterno bianco oppure smaltato oro o platino, provvisto di piatto copri scarico in ceramica. Struttura portante in acciaio inox satinato, provvista di ripiano porta salviette in vetro o marmo. Predisposto per fissaggio a parete. Le parti in legno sono disponibili anche in finitura laccata lucida. Le parti in metallo sono disponibili nella selezione finiture metalliche. Compatibile con linea accessori bagno Kobol.

*Console with two washbasins, wooden cabinet with two drawers with side and back in solid wood carved in bas-relief with "canneté" processing, internally covered in satin stainless steel. Boxed marble top with raised rear part to support the taps. The faucets and the knobs are made of solid chromed brass. Glazed ceramic washbasin with white, gold or platinum enamelled exterior, provided with ceramic drain plate. Structure in brushed stainless steel, equipped with glass or marble towel shelf. Prepared for wall mounting. Wooden parts are also available in polished lacquered finish. Metal parts available in the metal finishing selection. Compatible with Kobol bathroom accessories line.*

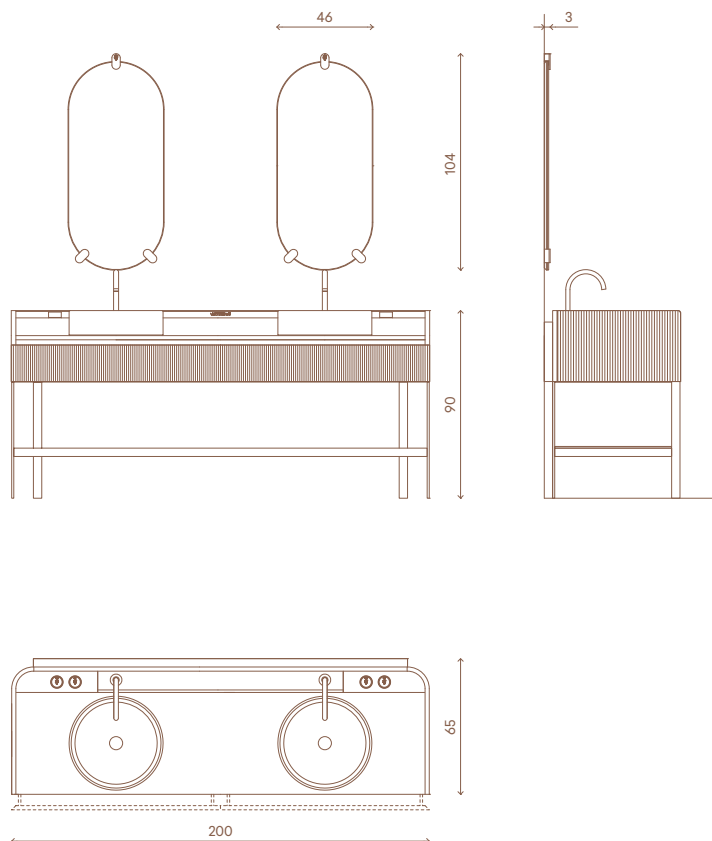

# KOBOL

Portasciugamani  
*Towel hanger*

Design  
Alessandro La Spada

Portasciugamani in acciaio inox satinato con portaoggetti in marmo.

*Satin stainless steel towel rail with marble storage rack.*

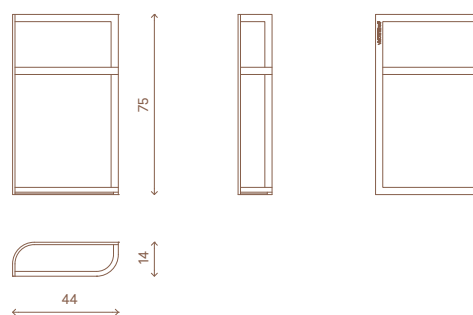

# KUIPER

Tappeto  
*Carpet*

Design  
La Conca

Tappeto taftato a mano in bamboo silk e lana con lavorazione carving manuale. Backing in cotone.

*Hand-tufted carpet in bamboo silk and wool with carving work. Cotton backing.*

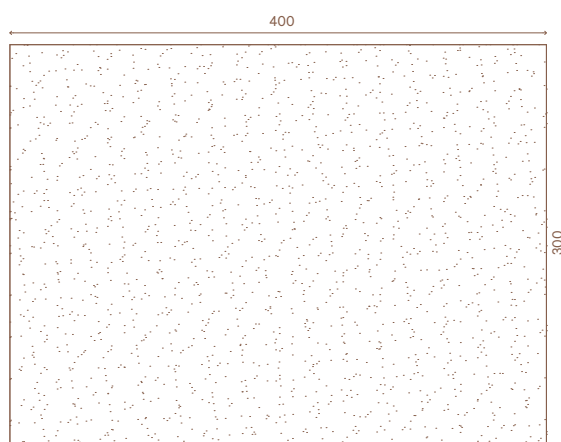

# KYNES

Lampada da tavolo  
*Table lamp*

Design  
Alessandro La Spada

Lampada da tavolo con basamento in marmo con due facce in acciaio inox satinato. Paralume in tessuto di raso stampato in digitale con grafica geometrica oppure in seta nera con interno bianco. Portalampada E27 max 60W. Disponibile in due misure. Le parti in acciaio sono disponibili nella selezione finiture metalliche satiniate.

*Table lamp with base in marble with two sides in satinized stainless steel. Lampshade in digital printed satin with geometric graphic or in black silk, with white interior. Bulb E27 max 60W. Available in two sizes. Metal parts available in the satinized metal finishing selection.*

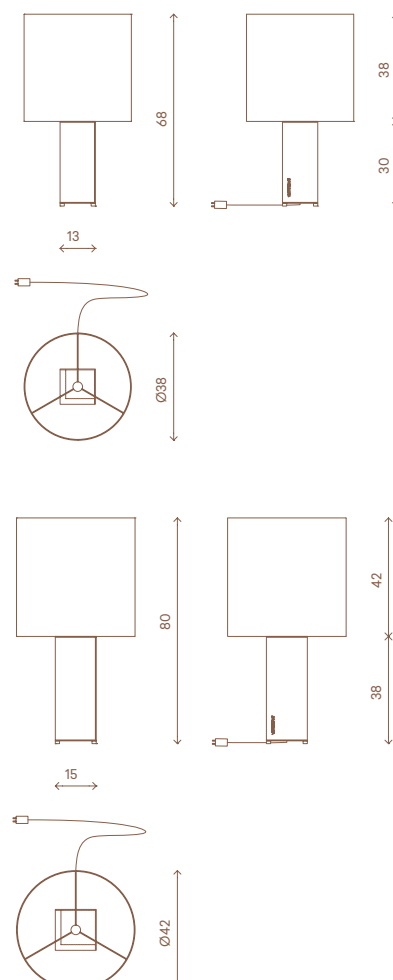

# LEGEND QUILTED

Poltrona  
Armchair

Design  
Fabio Bonfà

Struttura in legno massello e multistrati con molleggio a cinghie elastiche, imbottitura in poliuretano a densità differenziate. Rivestimento in pelle o tessuto. Retro schienale trapuntato. Piedi posteriori rivestiti in pelle o tessuto. Base e piedi anteriori in acciaio inox satinato sono disponibili nella selezione finiture metalliche.

*Structure in solid wood and plywood with elastic straps, padding in polyurethane with different densities. Upholstered in leather or fabric. Quilted backrest. Rear feet upholstered in leather or fabric. Base and front feet in satinized stainless steel available in the metal finishing selection.*

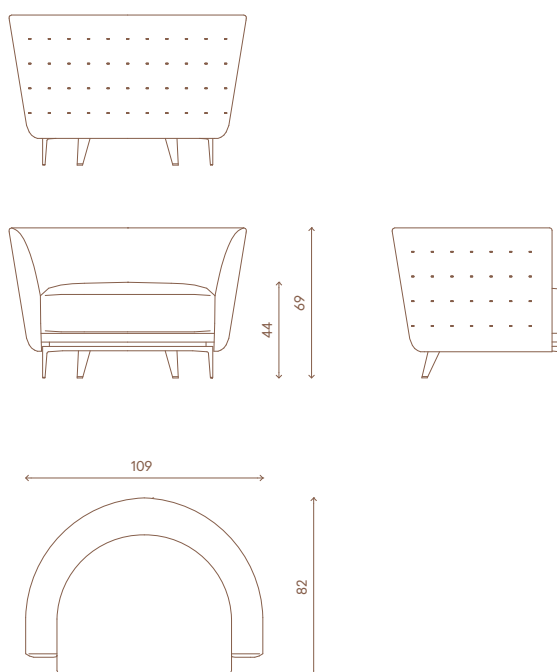

# LYDIA

Lampada da tavolo  
Table lamp

Design  
Giuseppe Viganò

Stelo a cuneo in massello di marmo sagomato e lucidato, base circolare in metallo e marmo, paralume a cupola in acciaio satinato con diffusore opalino, illuminazione a fluorescenza 40W. Versioni in metallo cromo, oro o bronzo.

*Wedge stem in shaped and polished solid marble, circular base in marble and metal, lampshade in brushed stainless steel with opal diffuser, fluorescent lighting 40W. Metal versions in chrome, gold or bronze.*

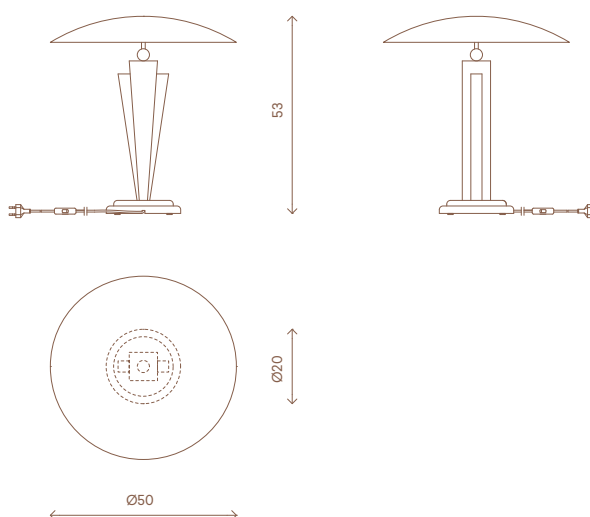

# MADDY

Lampada a sospensione  
Suspension lamp

Design  
Alessandro La Spada

Lampada a sospensione in marmo lavorato da massello e lucidato a mano, con ghiera in ottone rigato e cavo di supporto in acciaio integrato nel cavo di alimentazione. Portalampe GU10 max 40W.

*Changing lamp in marble obtained from solid marble and hand-polished, with ring in striped brass and steel support cable integrated in the power cord. Bulb GU10 max 40W.*

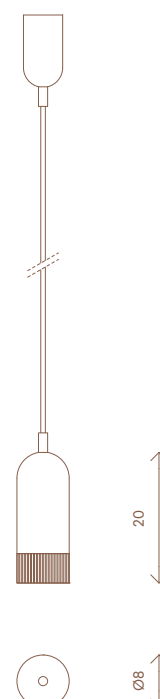

# MARTY

Consolle  
Console

Design  
Marco Piva

Consolle in vetro composta da due basamenti rivestiti in specchio bronzo con superficie cannettato in rilievo. Top in cristallo fumé sp.8 mm scatola tramite saldatura UV. Ulteriori top di finitura in acciaio inox satinato in corrispondenza delle basi. Le parti in metallo sono disponibili nella selezione finiture metalliche satinato.

*Glass console composed of two bases covered in bronze mirror with embossed surface in relief. Smoked crystal top th.8 mm boxed by UV bonding. Additional finishing tops in brushed stainless steel at the bases. The metal parts are available in the metal satinized finishing selection.*

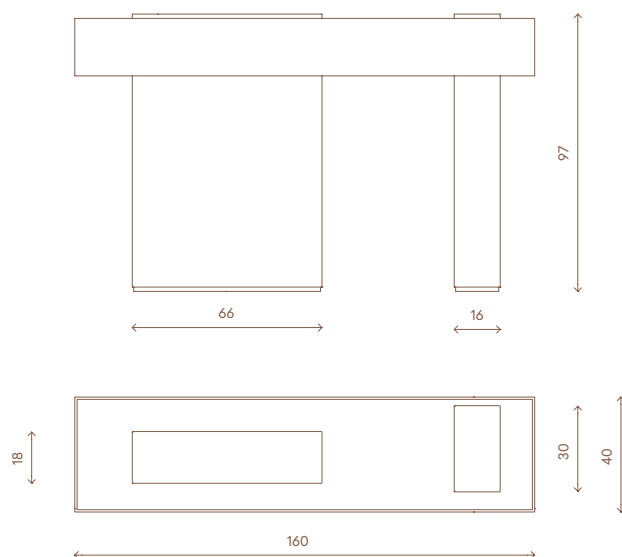

# MARTY

Tavolo basso  
Low table

Design  
Marco Piva

Tavolo basso composto da tre basamenti rivestiti in marmo e acciaio inox satinato. Top in cristallo fumé sp.8 mm scatola tramite saldatura UV. Ulteriori top di finitura in marmo e acciaio inox satinato a materiali alterni in corrispondenza delle basi. Le parti in metallo sono disponibili nella selezione finiture metalliche satinato.

*Coffee table composed of three bases covered in marble and satin stainless steel. Smoked crystal top th.8 mm boxed by UV bonding. Additional finishing tops in marble and stainless steel with alternating materials at the bases. The metal parts are available in the metal satinized finishing selection.*

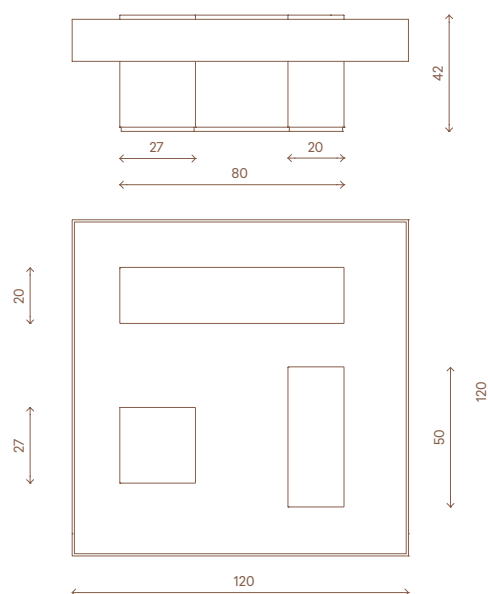

# MARVEL

Tappeto  
Carpet

Design  
Alessandro La Spada

Tappeto taftato a mano 100% in Bamboo Silk, disegno a motivo marmoreo, a diverse tonalità. Gli angoli smussati ospitano quattro inserti in ottone satinato con logo Visionnaire inciso in bassorilievo. Backing in cotone.

*Hand-tufted carpet, 100% Bamboo Silk. Marble-like pattern in different shades. Rounded corners with four inserts in satinized brass with Visionnaire logo engraved in bas-relief. Backing in cotton.*

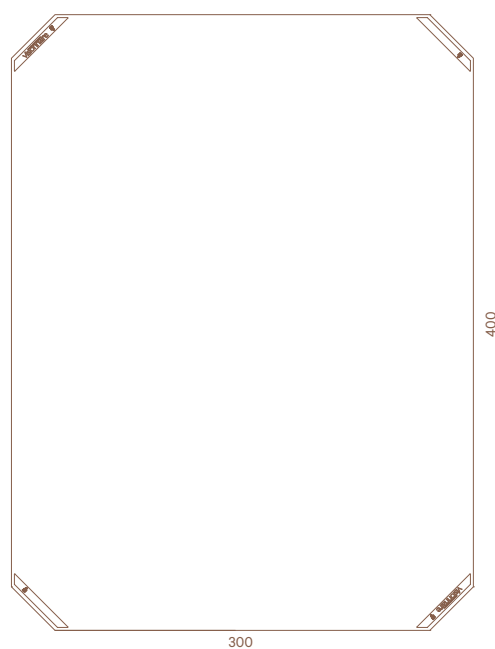

# MEDUSA

Plafoniera  
Ceiling Lamp

Design  
Philippe Montels

Lampadario a plafoniera composto da sfere in vetro coperte da un drappo di maglia in acciaio inox o bronzo. Altezza delle singole sfere regolabile. Piastra a soffitto in acciaio inox. Portalampane G9 max 40W cad.

*Ceiling light made of glass spheres covered by a chain mesh in natural or bronze stainless steel. Adjustable height for each single sphere. Ceiling plate in stainless steel. Bulb G9 max 40W each.*

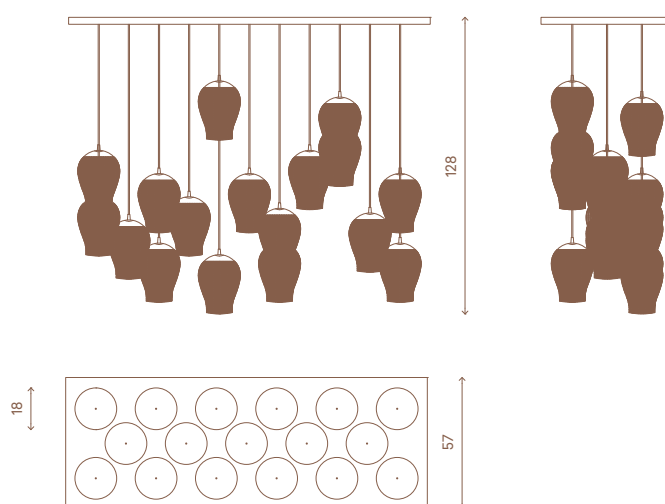

# MIKA

Poltroncina  
Armchair

Design  
Giuseppe Viganò

Poltrona tappezzata in pelle o tessuto, con schienale curvo a doppio elemento con cuciture ribattute. Scocca interna in legno massello e multistrati, dotata di molleggio a cinghie elastiche. Seduta in poliuretano, memory foam® e piuma. Cuscini volanti in piuma. Base in legno curvo, rivestita in acciaio inox satinato con meccanismo girevole auto-raddrizzante. Le parti in metallo sono disponibili nella selezione finiture metalliche.

*Upholstered armchair in leather or fabric, with twin-element curved backrest with rivested seams. Inner shell in solid wood and plywood, equipped with elastic belts springing. Seat in polyurethane, memory foam® and feather. Loose cushions in feather. Base in curved wood, covered in satin stainless steel with self-adjusting rotating mechanism. The metal parts are available in the metal finishing selection.*

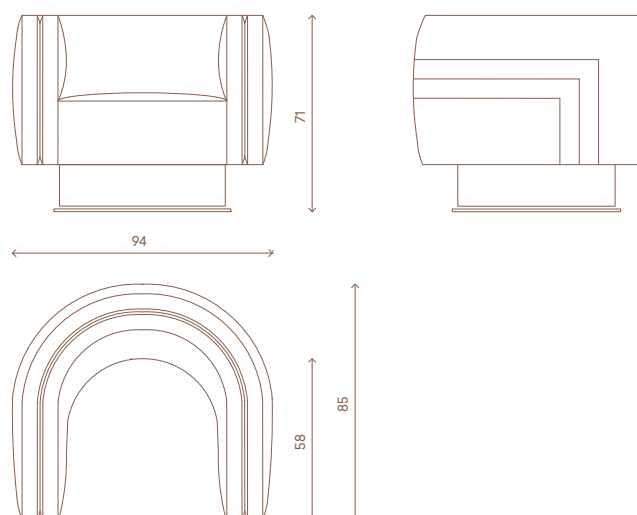

# MILO

Specchiera  
Mirror

Design  
Roberto Lazzeroni

Specchiera in tre sezioni cromatiche con parti in specchio naturale, rosa e azzurro. Cornice in acciaio inox satinato separata dallo specchio da quattro elementi in ottone. Fondo in legno nero.

*Mirror in three chromatic sections with parts in natural, pink and blue mirror. Satinized stainless steel frame separated from the mirror by four brass elements. Black wooden back.*

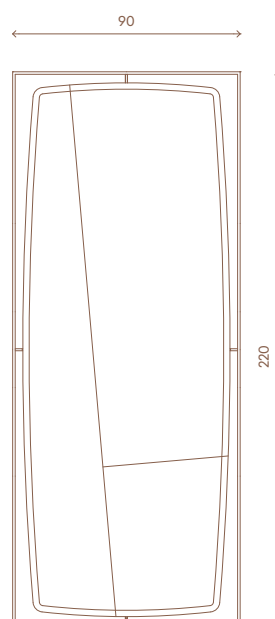

# MINSTREL

Tavolino  
Low table

Design  
Alessandro La Spada

Tavolino con corpo centrale in legno rivestito in essenza, disponibile nelle finiture selezione essenze. Base in acciaio inox satinato con logo Visionnaire, disponibile nella selezione finiture metalliche satiniate.

*Low table with central part in wood covered in veneer, available in the veneer selection finishings. Base in satinized stainless steel with Visionnaire logo, available in the satinized metal finishing selection.*

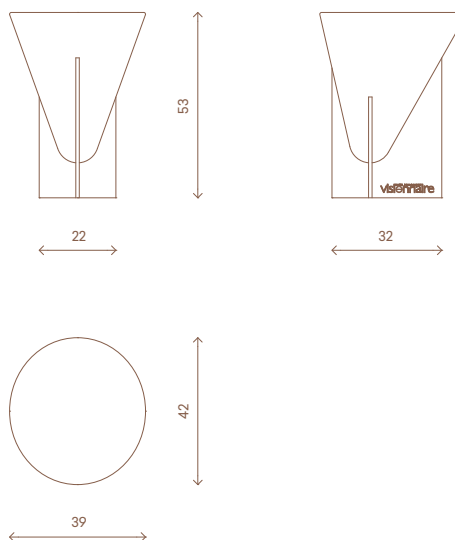

# NOMOS

Cassettiera  
Chest of drawers

Design  
Roberto Lazzeroni

Cassettiera a 6 cassetti con corpo centrale semi-ellittico in legno curvato su tutti i lati, superficie esterna con profili a rilievo, finitura laccato lucido. Top in marmo inserito in una cornice sagomata in legno massello di rovere con finitura nera a poro aperto. Base conica in legno nero e profilo inferiore in metallo satinato. Interno cassetti in essenza rovere nero e interno in microfibra nera. Disponibile nella versione "Wall" con schienale piatto.

*Chest of drawers with 6 drawers with semi-elliptical central body in curved wood on all sides, external surface with raised profiles, glossy lacquered finish. Marble top inserted in a molded frame in solid Oak wood with black open-pore finish. Conical base in black wood and lower profile in satin metal. Drawers interiors in black oak and black microfibre inside. Also available in the "Wall" version with flat back.*

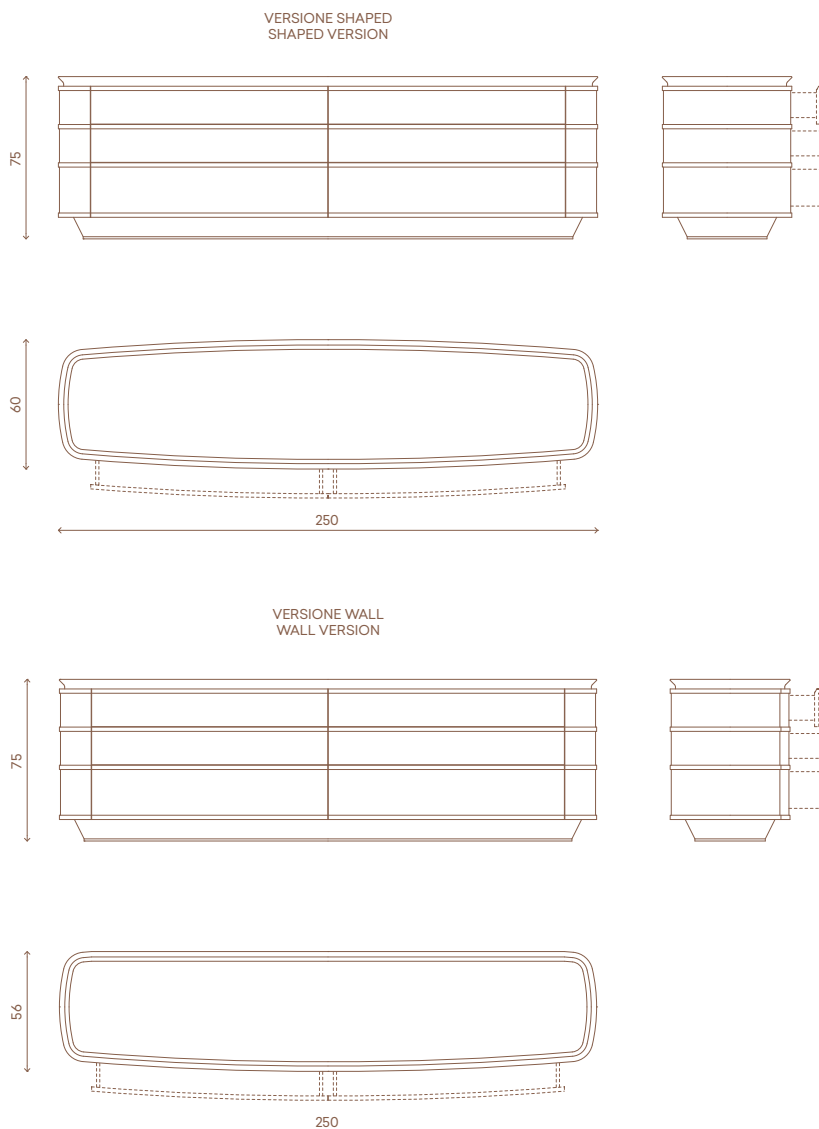

# NOMOS

Comodino  
Bedside table

Design  
Roberto Lazzeroni

Comodino con 2 cassetti con corpo centrale semi-ellittico in legno curvato su tutti i lati, superficie esterna con profili a rilievo, finitura laccato lucido o rivestito in pelle. Top in marmo inserito in una cornice sagomata in legno massello di rovere con finitura nera a poro aperto. Base conica in legno nero e profilo inferiore in metallo satinato. Interno cassetti in essenza rovere nero e interno in microfibra nera.

*Bedside table with 2 drawers with semi-elliptical central body in curved wood on all sides, external surface with raised profiles, glossy lacquered finish or covered in leather. Marble top inserted in a molded frame in solid Oak wood with black open-pore finish. Conical base in black wood and lower profile in satin metal. Drawers interiors in black oak and black microfibre inside.*

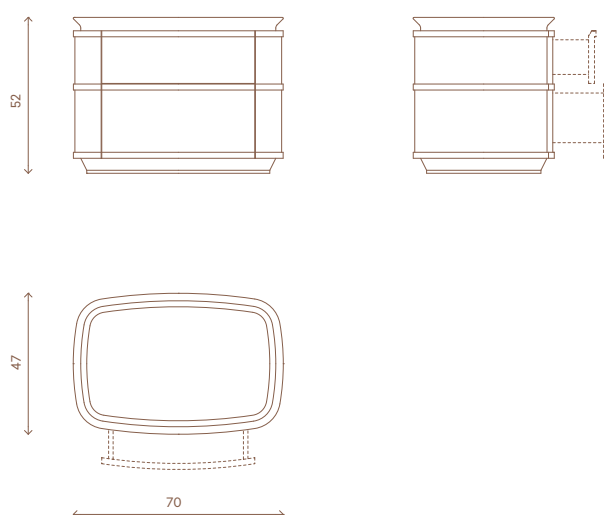

# NOMOS

Madia  
Cabinet

Design  
Roberto Lazzeroni

Mobile alto con 4 ante, corpo centrale semi-ellittico in legno curvato su tutti i lati, superficie esterna con profili a rilievo, finitura laccato lucido. Top in marmo inserito in una cornice sagomata in legno massello di rovere con finitura nera a poro aperto. Base conica in legno nero e profilo inferiore in metallo satinato. Interno mobile provvisto di ripiani e cassetti, finito in radica di eucalipto con finitura a poro aperto e schienali a specchio fumè. Cassetti rivestiti in cuoio con interno in microfibra. Disponibile con illuminazione interna a LED. Disponibile nella versione "Wall" con schienale piatto.

*Cabinet with 4 doors, semi-elliptical central body in curved wood on all sides, external surface with raised profiles, glossy lacquered finish. Marble top inserted in a molded frame in solid Oak wood with black open-pore finish. Conical base in black wood and lower profile in satin metal. Interiors with shelves and drawers, finished in eucalyptus root with open pore finish and smoked mirror backs. Drawers covered in leather with microfibre lining. Available with internal LED lighting. Also available in the "Wall" version with flat back.*

VERSIONE SHAPED  
SHAPED VERSION

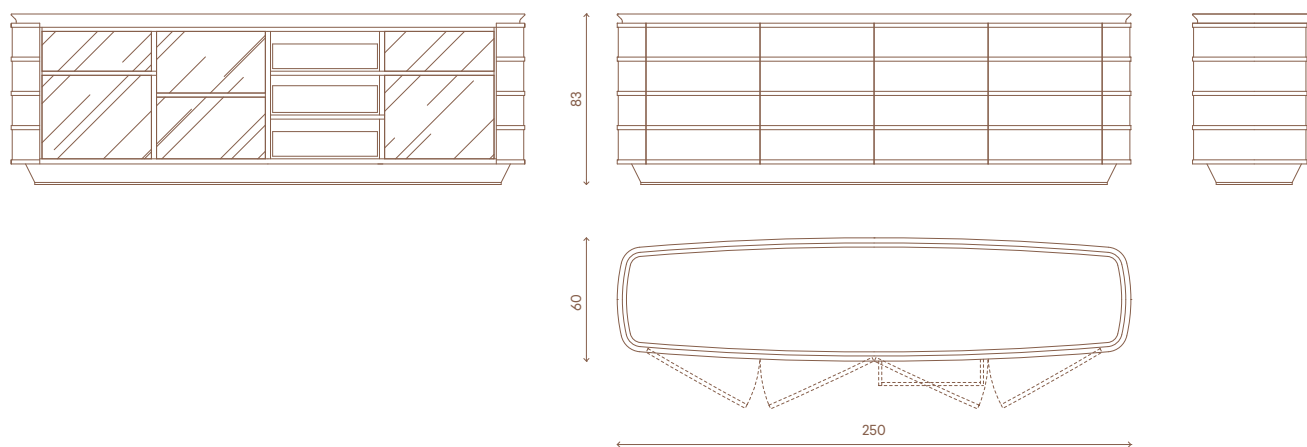

VERSIONE WALL  
WALL VERSION

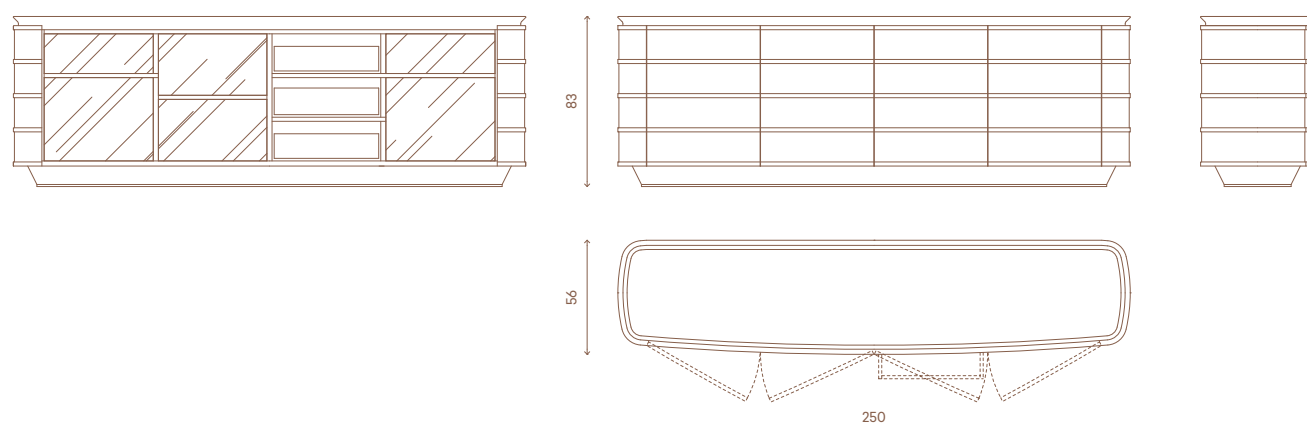

# NOMOS

## Mobile bar Bar cabinet

Design  
Roberto Lazzeroni

Mobile bar con 4 ante, corpo centrale semi-ellittico in legno curvato su tutti i lati, superficie esterna con profili a rilievo, finitura laccato lucido. Top in marmo inserito in una cornice sagomata in legno massello di rovere con finitura nera a poro aperto. Base conica in legno nero e profilo inferiore in metallo satinato. Le due ante laterali si aprono sui fianchi del mobile. Interno mobile provvisto di ripiani ed un cassetto, finito in radica di eucalipto con finitura a poro aperto e schienali a specchio fumè. Cassetto centrale rivestito in cuoio con interno in microfibra. Disponibile con illuminazione interna a LED.

Bar cabinet with 4 doors, semi-elliptical central body in curved wood on all sides, external surface with raised profiles, glossy lacquered finish. Marble top inserted in a molded frame in solid Oak wood with black open-pore finish. Conical base in black wood and lower profile in satin metal. The two side doors open on the sides of the cabinet. Interiors with shelves and drawers, finished in eucalyptus root with open pore finish and smoked mirror backs. Drawer covered in leather with microfibre lining. Available with internal LED lighting.

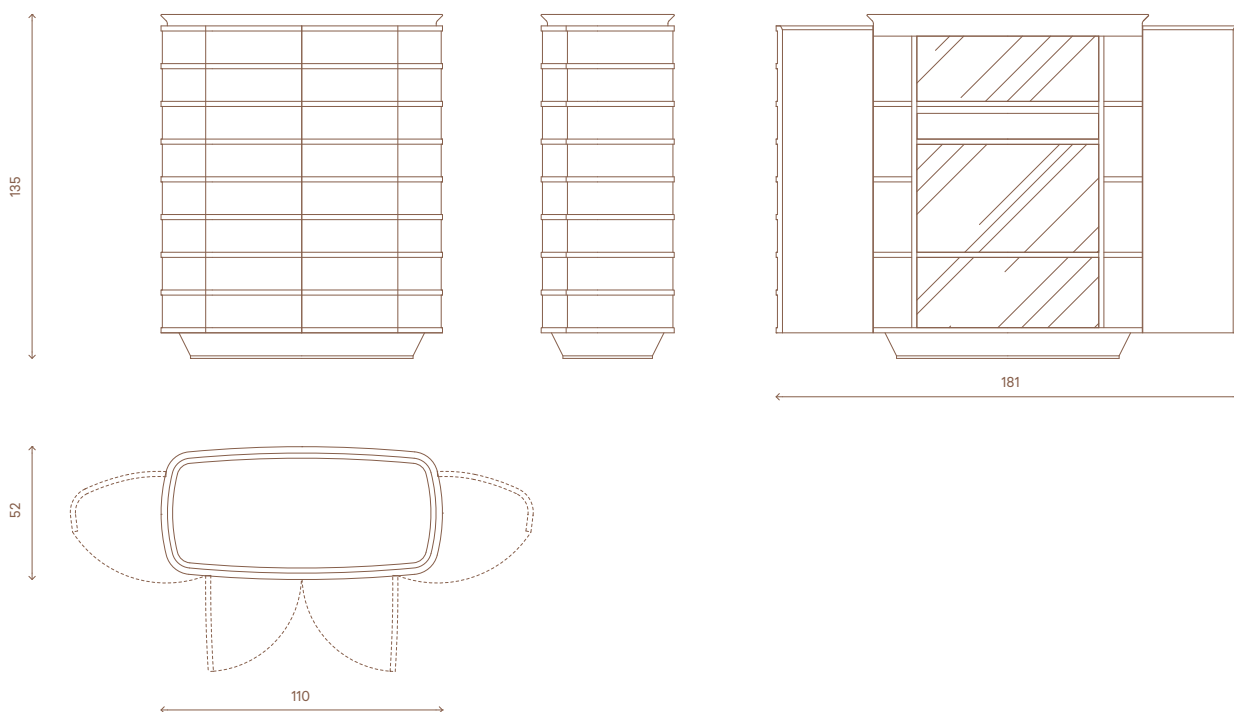

# OBERTO

## Tavolo basso Low table

Design  
Samuele Mazza

Struttura portante realizzata in manao scortecciato e laccato con legature in cuoio e fascette metalliche finitura inox lucido con incisione stemma araldico Visionnaire. Top in marmo o in vetro retro laccato. Sconsigliato l'uso in ambienti completamente esposti alle intemperie.

Main structure made in stripped and lacquered manao wood with bindings in cuoio leather and metal clips in shiny stainless steel with Visionnaire engraved coat of arms. Top in marble or in back-lacquered glass. Not recommended for use in environments completely exposed to the elements.

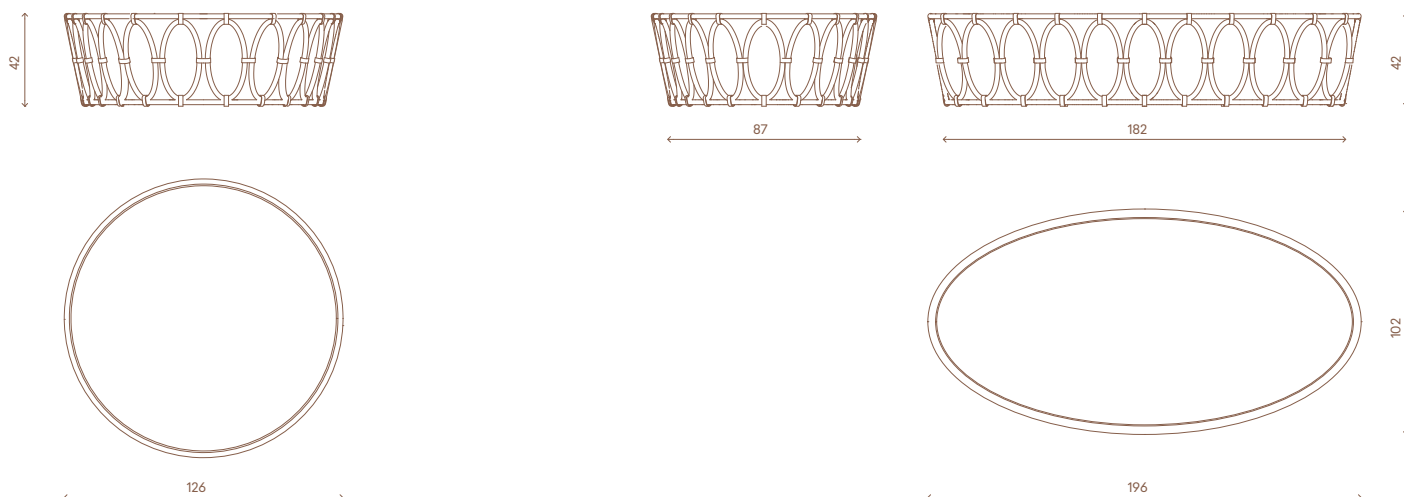



# OMEGA

Lampada da tavolo  
Table lamp

Design  
Fabio Bonfà

Lampada da tavolo con diffusore in cristallo molato a mano ad alto spessore, incorniciato da un anello in acciaio contenente una sorgente luminosa a LED da 9W a luce calda dimmerabile. L'anello è sostenuto da una coppia di steli in ottone connessi con una base circolare in marmo. Le parti metalliche sono disponibili nella selezione finiture metalliche.

*Table lamp with diffuser in hand-cut crystal of high thickness, framed by a steel ring containing a 9W LED light source with warm dimmable light. The ring is supported by a pair of brass stems connected to a circular marble base. Metal parts available in the metal finishing selection.*

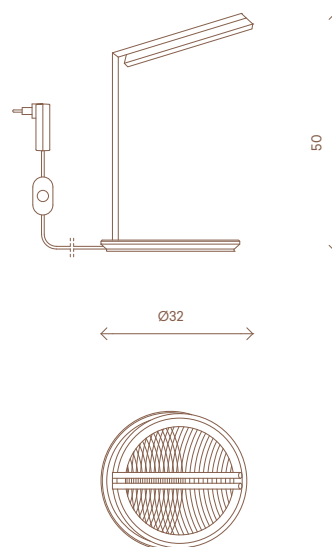

# OPERA

Tavolo da pranzo  
Dining table

Design  
Alessandro La Spada

Struttura in legno con top e base rivestita in essenza o laccata, basamento a pianta circolare sfalsata con lavorazione cannettata, profili decorativi e base in acciaio inox satinato con logo Visionnaire inciso. Sottotop in alluminio verniciato. Top accessorato da tre fregi metallici sul bordo e meccanismo circolare a cuscinetto rotante "Lazy Susan" a filo top, indipendente ed estraibile. Le parti in legno sono disponibili nelle finiture selezione essenze; gli elementi metallici sono disponibili nella selezione finiture metalliche satiniate.

*Structure in wood with top and base upholstered in veneer or lacquered, staggered base with cannetté decoration, decorative profiles and base in satinized stainless steel with engraved Visionnaire logo. Undertop in painted aluminium. Top decorated with 3 metal friezes on the edge and turning "Lazy Susan" built in the top, removable. Wooden parts available in the veneer selection finishings; metal parts available in the satinized metal finishing selection.*

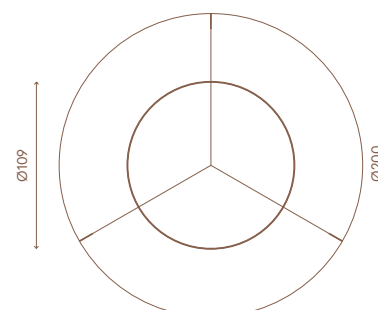
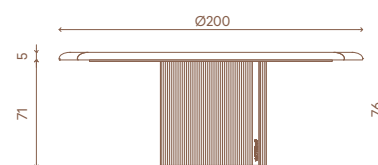
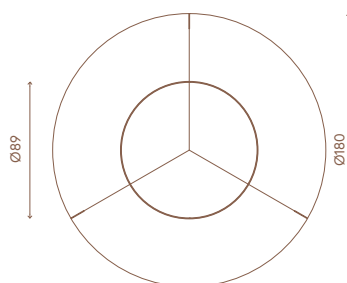
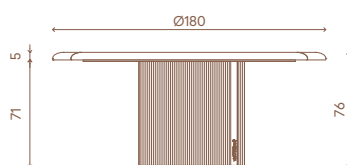
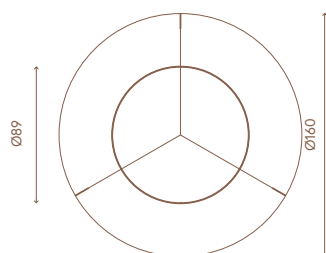
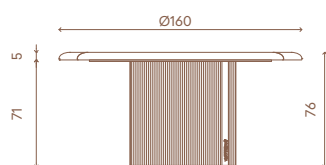

# PARKER

Mobile basso  
Low unit

Design  
Fabio Bonfà

Mobile basso a quattro ante e due cassetti.  
Struttura in MDF rivestita in essenza con inserti in acciaio inox satinato incastonati nel legno. Ante in legno scolpito in bassorilievo con disegno a rombi, top in marmo. Base con piedi in acciaio inox satinato, Interno laccato opaco, schienale laccato opaco, in opzione disponibile in essenza. Le parti in legno sono disponibili nelle finiture opache B.180, B.181, B.182, C.001. Le parti metalliche sono disponibili nella selezione finiture metalliche satiniate.

*Low cabinet with four doors and two drawers.  
Structure in MDF covered in wood with inserts in satin stainless steel embedded in the wood. Wooden doors carved in low relief with diamond pattern, marble top. Base with feet in brushed stainless steel, matt lacquered interior, matt lacquered back, optional available veneered. The wooden parts are available in matt finishes B.180, B.181, B.182, C.001. Metal parts available in the satinized metal finishing selection.*

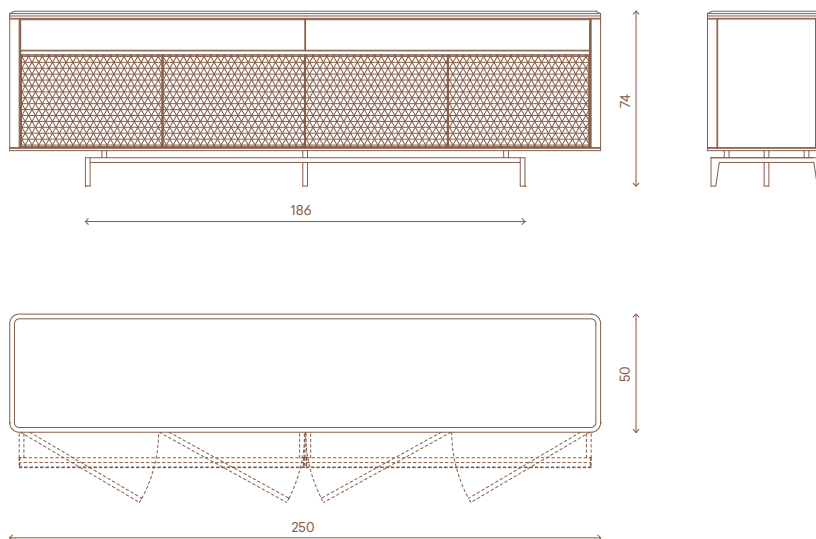

# POLIDORO

Specchiera  
Mirror

Design  
Alessandro La Spada

Specchiera con cornice in marmo inserita in un telaio portante in tubolare di acciaio inox, la cornice è composta da pannelli in due tipologie di marmo con inserti in acciaio satinato; specchio bisellato. Le parti metalliche sono disponibili nella selezione finiture metalliche satiniate.

*Mirror with marble frame inserted in a stainless steel tubular frame, the frame is composed of panels in two types of marble with satinized steel inserts; bevelled mirror. Metal parts available in the satinized metal finishing selection.*

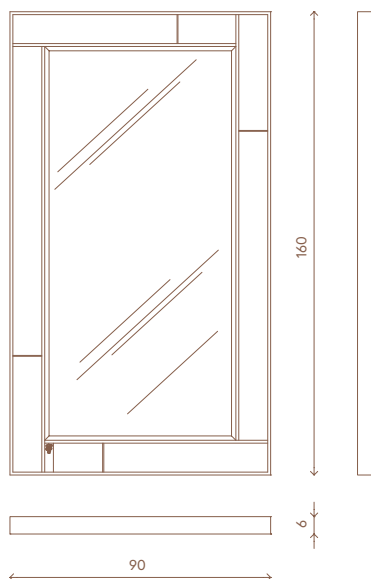

# POMPEI

Tappeto da esterno  
Outdoor carpet

Design  
La Conca

Tappeto taftato a mano in polipropilene con lavorazione carving manuale lungo il disegno. Backing in cotone.

*Hand-tufted carpet in polypropylene with carving work. Cotton backing.*

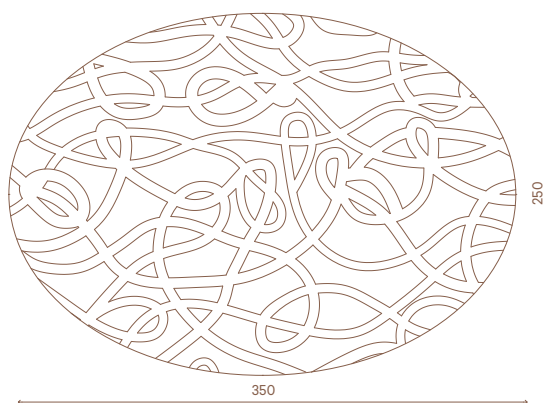

# RAIDHO

Tavolo da pranzo  
Dining table

Design  
Steve Leung

Top in marmo e ametista intarsiato con disegno composto da Mistery White, Nero Marquina, Ametista Viola e profilo di acciaio inox sp.3mm finitura cromo. Cornice del piano in acciaio inox con decoro geometrico ottenuto con tre diverse lavorazioni a mano di lucidatura e satinatura. Sottotop in legno tornito, laccato lucido 100 gloss (colori RAL). Basamento composto da una colonna conica su base sagomata in metallo cromato. Stelo portante e zavorra sotto la base in ferro verniciato. Sono disponibili combinazioni diverse. Cornice top solo finitura cromo. Base disponibile in finitura oro, bronzo oppure nickel nero. Lazy Susan in marmo con costa lavorata e sistema a cuscinetto rotante.

Marble and amethyst inlaid top with design in Mistery White, Nero Marquina, Purple Amethyst and 3mm stainless steel profile chrome finishing. Top frame in stainless steel with geometric decoration obtained through different handmade procedures of polishing and brushing. Under top of turned lacquered polished 100 gloss wood (RAL colours). Base composed by a conical column on a shaped chromed metal base. Central support and ballast under base in painted iron. Several combinations are possible. Top profile in chromed finishing. Base metal parts are available in golden, bronze and black nickel finishing. Lazy Susan in marble with safety edge and rotating weight holder system.

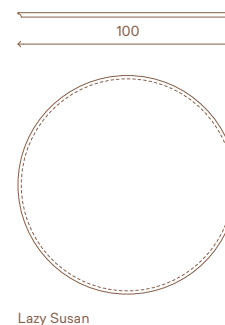
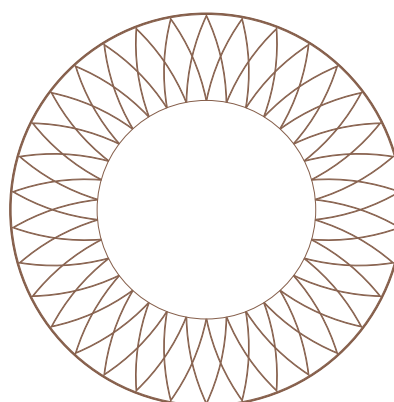
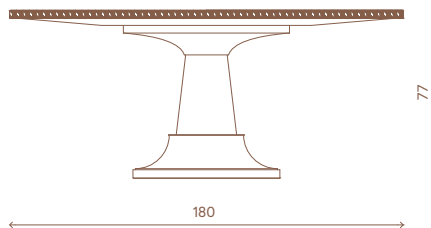

# RAWDON

Mobile basso, Cassettiera  
Low cabinet, Chest of drawers

Design  
La Conca

Mobile a doppia profondità con 4 ante oppure 4 cassetti ad apertura push-pull con finitura laccata lucida o rivestita in essenza. Interno laccato opaco (colori RAL), fianchi e top rivestiti in pelle. Cornice perimetrale incassata rivestita in specchio (naturale/bronzo/fumé) con effetto "labirinto". Profili frontali in acciaio inox lucido oppure in finitura laccata oro, bronzo o nickel nero. Le parti in legno sono disponibili nelle finiture selezione essenze.

Unit with double depth with 4 doors or 4 drawers and push-pull opening. The doors and drawers can be lacquered and polished or in veneered wood. Mat lacquered inside (RAL colours), top and laterals upholstered in leather. Perimetral built-in frame covered with "labyrinth effect" mirror (natural/bronze/fume). Frontal outline in polished stainless steel or in lacquered gold, bronze or black nickel. Wooden parts are available with veneer selection finishings.

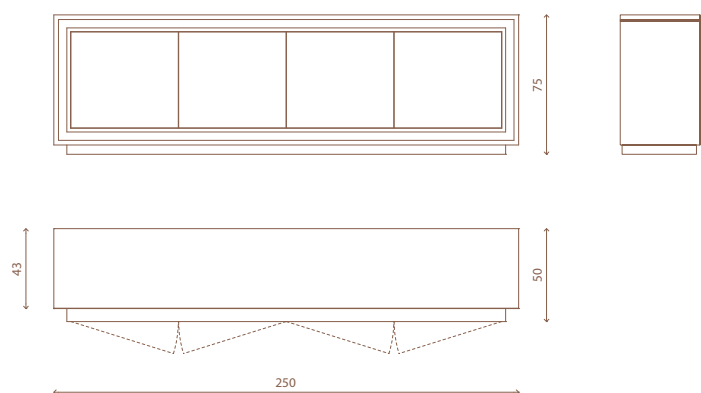
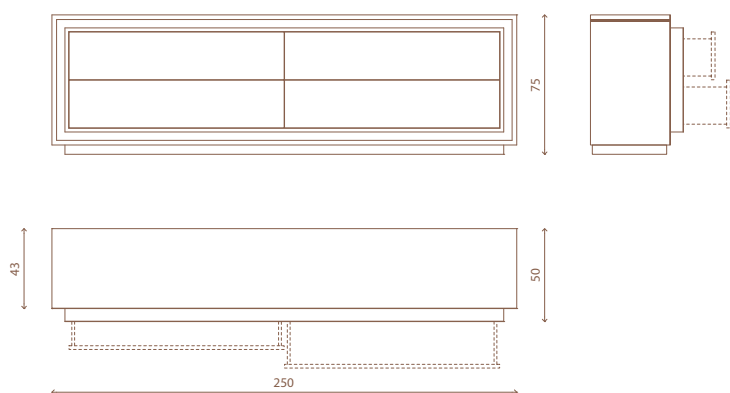

# RAWDON

Mobile trucco  
Make-up desk

Design  
La Conca

Struttura in multistrati e MDF rivestita interamente in pelle, interno cassetto laccato opaco a colori RAL, cornice perimetrale frontale incassata rivestita in specchio (naturale/ bronzo/fumé). Retro del mobile laccato opaco, cornici frontali in acciaio inox satinato con logo Visionnaire inciso. Sottomano in legno laccato o rivestito in essenza con finitura lucida. Specchiera superiore con profilatura perimetrale in acciaio inox satinato, specchio con bordo retroilluminato a LED, diponibile con retro laccato opaco oppure rivestito in pelle. Le parti in acciaio sono disponibili nella selezione finiture metalliche satiniate. Il sottomano è disponibile nelle finiture selezione essenze.

Structure in plywood and MDF fully covered in leather, internal drawer in mat lacquer (RAL colours), front built-in perimetral frame in mirror (natural/bronze/smoked). Rear back in mat lacquer, front frames in satinized stainless steel with laser Visionnaire logo. Desk pad in lacquered wood or veneered with shiny finishing. Upper mirror with perimetral profile in satinized stainless steel, mirror with back-lightened LED edge, available with rear part in mat lacquer or covered in leather. Metal parts available in the satinized metal finishing selection. The desk pad is available in the veneer finishing selection.

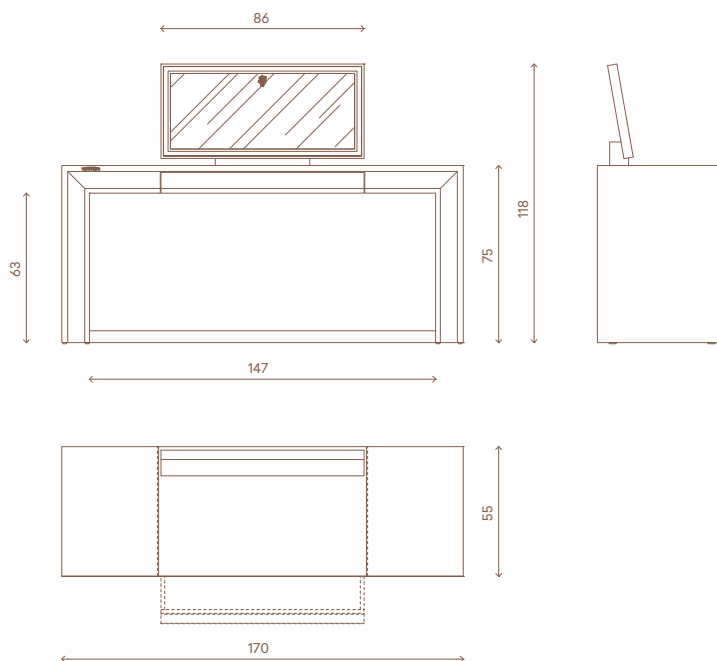

# REGIS

Tappeto  
Carpet

Design  
La Conca

Tappeto taftato a mano in bamboo silk e lana New Zealand con lavorazione carving manuale. Backing in cotone.

Hand-tufted carpet in bamboo silk and New Zealand wool with carving work. Cotton backing.



# REMY-17

Tappeto  
Carpet

Design  
Alessandro La Spada

Tappeto taftato a mano 100% Bamboo Silk, disegno a motivo geometrico tono su tono con lavorazione in bassorilievo. Un angolo ospita un inserto in ottone satinato con logo Visionnaire inciso in bassorilievo. Backing in cotone.

Hand-tufted carpet. 100% bamboo silk. Tone-ontone geometrical pattern with bas relief work. A corner contains an insert in satinized brass with Visionnaire logo engraved in bas-relief. Backing in cotton.

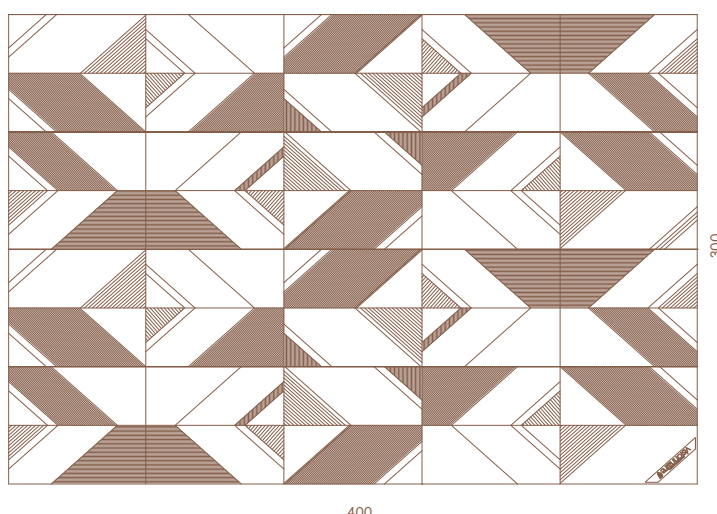

# RÊVERIE

Letto  
Bed

Design  
Roberto Lazzeroni

Letto imbottito in pelle o tessuto con testata alta divisa in due sezioni orizzontali a diversa inclinazione. La parte esterna può essere rivestita in contrasto con la parte interna, divise da un filetto in pelle. Sommier imbottito con giroletto inclinato verso l'interno e basamento in legno laccato lucido con angolari decorativi in ottone satinato. Struttura interna in masselli e multistrati di legno, rete a doghe in legno massello. Supporti rete/materasso regolabili in altezza. Le parti in metallo sono disponibili nella selezione finiture metalliche.

*Upholstered bed in leather or fabric with high head divided into two horizontal sections with different inclination. The external part can be covered in contrast with the inner part, divided by a leather thread. Padded sommier with inwardly inclined bed frame; polished lacquered wooden base with decorative satin brass corners. Internal structure in solid and multilayer wood, solid wood slatted base. Height adjustable slats/mattress supports. Metal parts available in the metal finishing selection.*

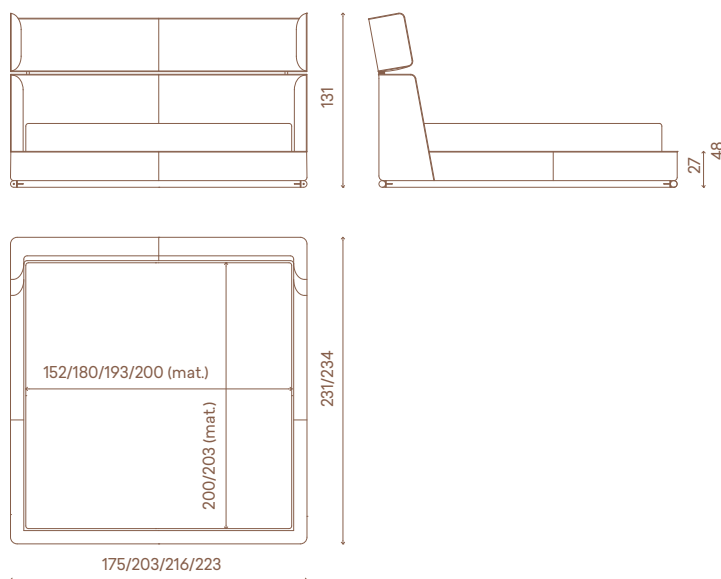

# RIPLEY

Letto  
Bed

Design  
Fabio Bonfà

Letto imbottito con testata trapuntata in pelle o tessuto, incorniciata da un profilo in legno rivestito in pelle o tessuto rifinito con un profilo in ottone. Fianchi della testata incassati nella cornice rivestiti in pelle o tessuto intrecciati, leggermente imbottiti. Disponibile con luce di cortesia a LED sui fianchi della testata con interruttori a sfioramento. Sommier in pelle o tessuto intarsiato con profili in ottone sul perimetro del giroletto. Struttura interna in masselli e multistrati di legno, rete a doghe in legno massello. Supporti rete e materasso regolabili in altezza.

*Upholstered bed with quilted headboard in leather or fabric, framed by a wooden profile covered in leather or fabric with a brass profile. Headboard sides embedded in the frame covered in leather or woven, slightly padded. Available with LED courtesy light on the sides of the head with touch switches. Sommier in leather or fabric inlaid with brass profiles around the bed frame. Internal structure in solid and multilayer wood, solid wood slatted base. Height adjustable slats/mattress supports.*

VERSIONE LARGE  
LARGE VERSION

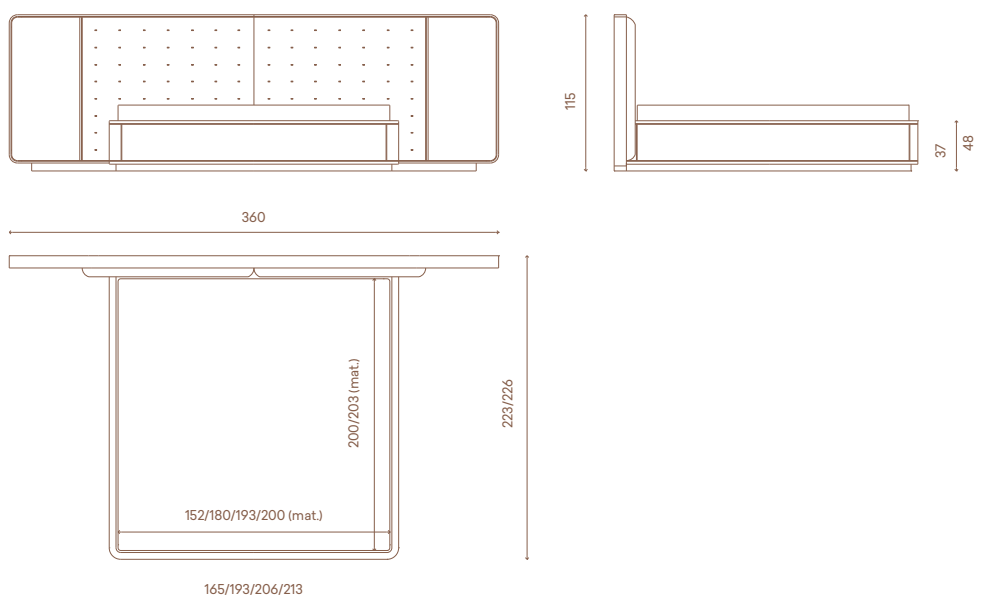

VERSIONE REGULAR  
REGULAR VERSION

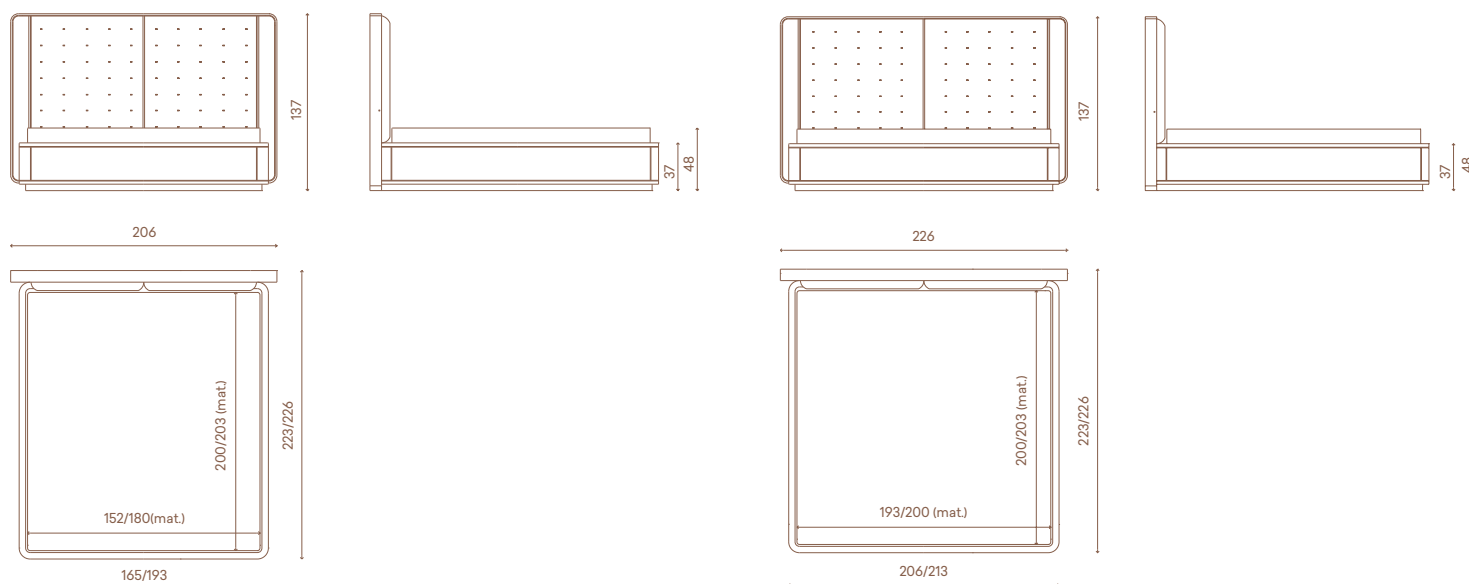

## RUPERT

Tavolo basso  
*Low table*

Design  
Roberto Lazzeroni

Tavolino basso ovale con top in fibra di legno lavorata dal pieno in forma organica con finitura laccata 100 gloss. Vano porta oggetti ricavato nel piano superiore. La parte inferiore del top, di sagoma eccentrica, confluisce in una base conica in marmo massiccio, scavato da unico blocco. Basetta di appoggio in acciaio satinato.

*Oval low table with top in wood fiber graven organic form with 100 gloss lacquered finish. Object compartment in the top. The lower part, of eccentric shape, flows into a conical base in solid marble, milled from a single block. Support base in brushed steel.*

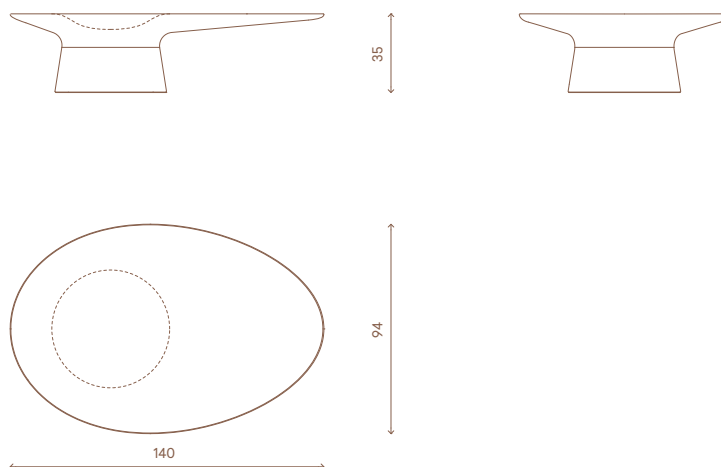

## RYLAN

Tavolo basso  
*Low table*

Design  
Mauro Lipparini

Tavolo basso ovale con basamento obliquo in legno rivestito in acciaio inox satinato. Top obliquo girevole in legno laccato lucido a colori RAL. Il top può ruotare di 360° con fermi in due posizioni (aperto/chiuso). Le parti in acciaio sono disponibili nella selezione finiture metalliche

*Oval coffee table with wooden oblique stand covered in satin stainless steel. Swivel oblique top in glossy lacquered wood (available in RAL colours). The top can rotate 360° with stops in two positions (open/closed). Metal parts available in the metal finishing selection.*

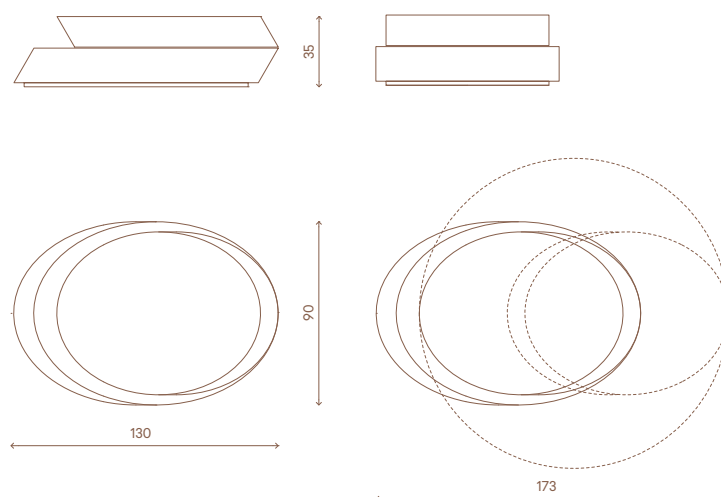

# SERENDIPITY

Mobile bar  
Bar cabinet

Design  
Alessandro La Spada

Struttura in multistrati e MDF, vani interni in nobilitato ad alta resistenza, con gole e zoccolo di base in acciaio inox satinato. Rivestimento frontale e laterale in marmo con lavorazione in bassorilievo ed inserti in acciaio inox. Top in marmo con profilo perimetrale in acciaio inox, piano di lavoro in acciaio inox satinato, ante esternamente rivestite in acciaio inox con doppia finitura lucido/satinato con motivo geometrico, pannello interno laccato. Zoccolo in multistrati marino rivestito in acciaio inox satinato. Accessori disponibili su richiesta: lavello in acciaio inox saldato a filo piano di lavoro, rubinetteria in acciaio inox con bocchetta orientabile, frigorifero sottotop. Le parti in metallo, tranne il piano di lavoro e le ante, sono disponibili nella selezione finiture metalliche satinato.

Structure in plywood and MDF, internal compartments in high-resistance ennobled wood, with grooves and base in satinized stainless steel. Front and sides covered in marble with bas-relief engraving and inserts in stainless steel. Top in marble with perimetral profile in stainless steel, working top in satinized stainless steel doors externally covered in stainless steel with shiny/satinized double finishing and geometric pattern, lacquered internal panel. Plinth in marine plywood covered in satinized stainless steel. Accessories available upon request: sink in satinized stainless steel flush with the worktop, taps in stainless steel with adjustable water outlet, fridge under top. Metal parts available in the satinized metal finishing selection.

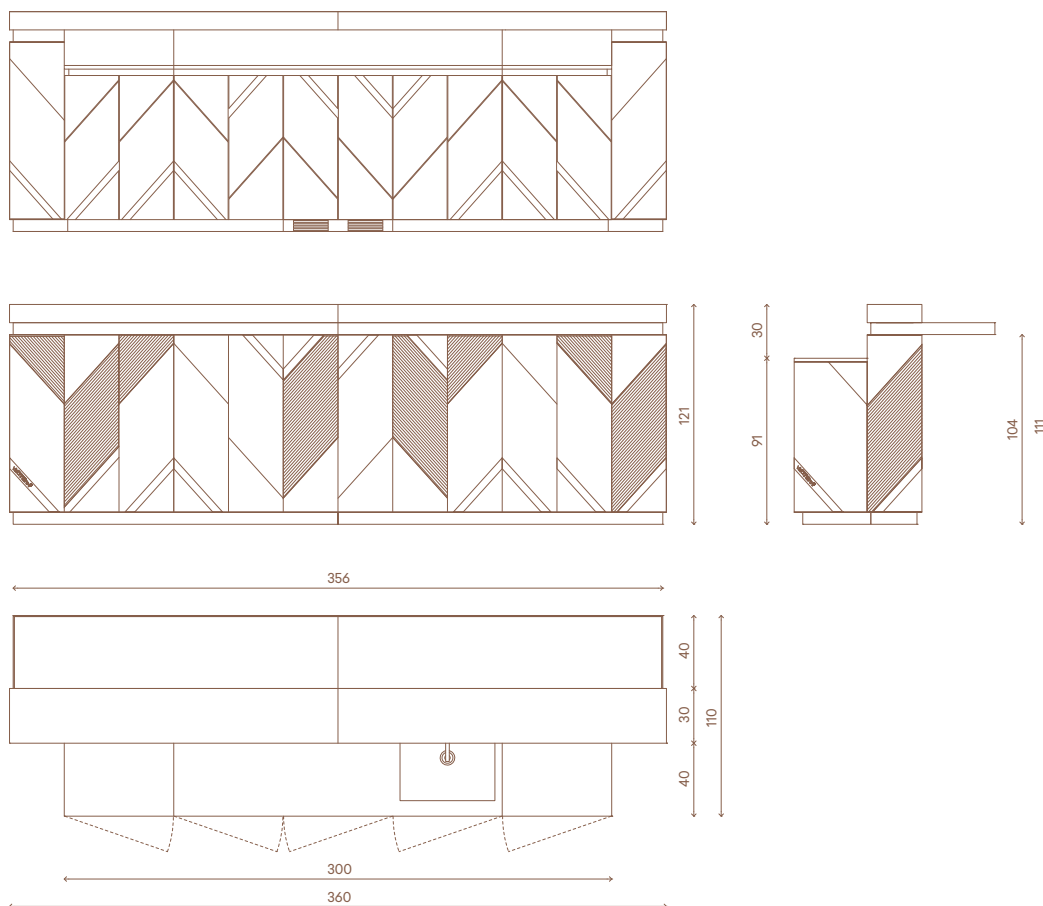

# SHAILA

Lampada da tavolo  
Table Lamp

Design  
Philippe Montels

Lampada da tavolo con base in acciaio cromato decorato con maglia in scaglie di alluminio naturale o champagne con illuminazione interna (due portalampada G9 max 40W). Paralume ellittico in seta nera con un portalampada E27 max 60W. Le parti in metallo sono disponibili nella selezione finiture metalliche.

Table lamp in chromed steel decorated with natural or champagne aluminium plates with internal lighting (2 G9 lampholders max 25W). Elliptical lampshade in black silk with one E27 lampholder max 60W. Metal parts available in the metal finishing selection.

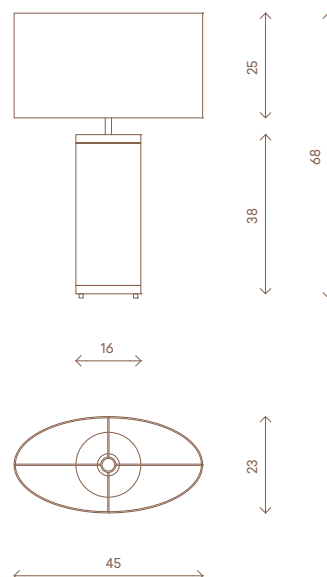

# SKIBA

Comodino  
*Bedside table*

Design  
Mauro Lipparini

Comodino tappezzato in pelle o tessuto con un cassetto e vano inferiore a giorno, struttura curva in multistrati leggermente imbottita, cassetto dotato di guide smorzate, interno laccato opaco e frontalino rivestito. Top e ripiano inferiore in specchio bronzo o fumé. Base curva in MDF rivestita in acciaio inox satinato. Parti metalliche disponibili anche lacca oro, champagne, bronzo, Siena, nickel nero, canna di fucile.

*Bedside table upholstered in leather or fabric with drawer and open lower shelf, slightly padded curved structure in plywood, drawer with damped runners, internal part matt lacquered and upholstered front part. Top and lower shelf in bronze or smoke mirror. Curved base in MDF, coated in satinized stainless steel. Metal parts available lacquered in gold, champagne, bronze, Siena, black nickel and gunmetal finishing.*

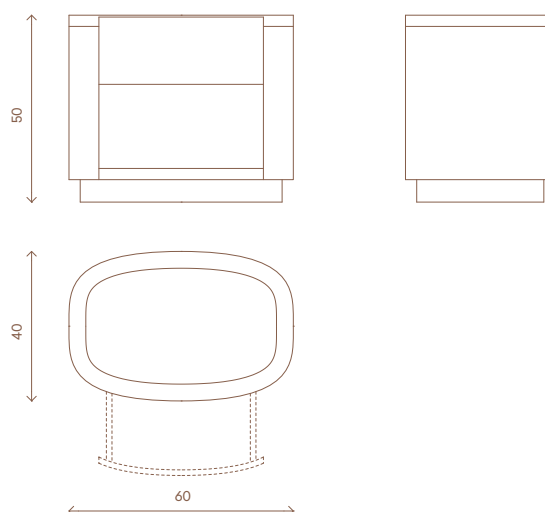

# SOWILO

Tavolo basso  
*Low table*

Design  
Steve Leung

Base a forma organica in resina nautica con finitura in vernice metallica (bronzo, oro, manganese, piombo) lucida, top in marmo a incasso e cornice in acciaio inox lucidato. Zoccolo in acciaio inox lucidato oppure oro, bronzo o nickel nero.

*Organic shape base in nautical resin finished with metallic paint, polished in golden, bronze, manganese or lead tones. Top in marble and frame in chromed polished stainless steel. Polished stainless steel plinth available also in gold, bronze or black nickel finishing.*

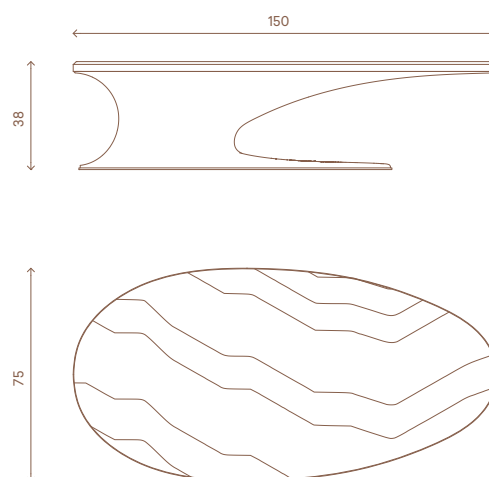

# SPEYER

Libreria  
*Bookshelf*

Design  
Alessandro La Spada - Samuele Mazza

Struttura portante in pannello multistrati e listelli in legno di abete. Fianchi, top e fronte rivestiti in vetro specchio bisellato, spessore mm 6. Rivestimento interno e di fondo in vetro specchio spessore mm 4.

*Support structure in plywood panels and fir wood strips. Sides, top and front covered in mirrored bevelled glass, thickness 6 mm. Internal and bottom covering in mirrored glass thickness 4 mm.*

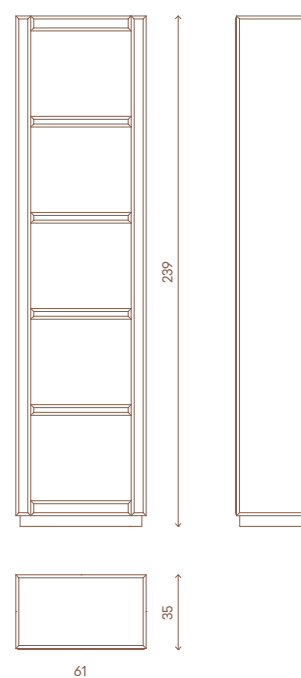



# STILO

Lampada da tavolo  
*Table lamp*

Design  
Alessandro La Spada

Struttura in ottone rigato con tagli obliqui e finitura bicolore lucida o satinata, paralume in tessuto stampato con disegno geometrico o seta nera, portalampade E27 max 60W. Le parti metalliche sono disponibili nella selezione finiture metalliche satinata.

*Structure in striped brass with oblique cut and shiny or satinized bicolour finishing, lampshade in printed fabric with geometric pattern or black silk, 1 bulb E27 max 60W. Metal parts available in the satinized metal finishing selection.*

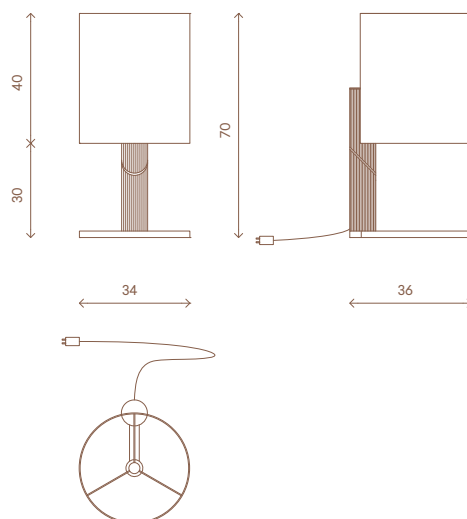

# STILO

Piantana  
*Floor lamp*

Design  
Alessandro La Spada

Struttura in ottone rigato con tagli obliqui e finitura bicolore lucida o satinata, paralume in tessuto stampato con disegno geometrico o seta nera, portalampade E27 max 60W.

*Structure in striped brass with oblique cut and shiny or satinized bicolour finishing, lampshade in printed fabric with geometric pattern or black silk, 1 bulb E27 max 60W.*

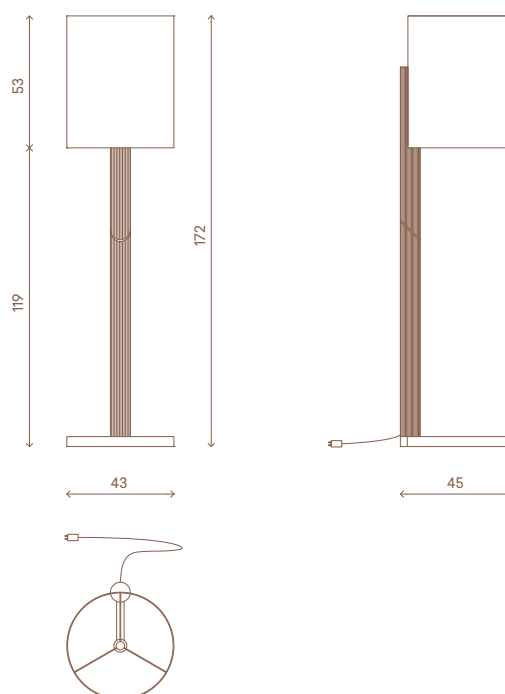

# STINGER

Tavolo basso  
*Low table*

Design  
Alessandro La Spada

Struttura portante in legno con rivestimento laterale in acciaio inox satinato. Base in legno cannetto, top in legno disponibile nella selezione essenze.

Opzione: gli elementi metallici sono disponibili satinati nella selezione finiture metalliche.

*Main structure in wood with side covered in satinized stainless steel. Base in cannetè wood, wood top available with veneer selection finishes. Option: metal parts available in the finishes included in the metal finishing selection.*

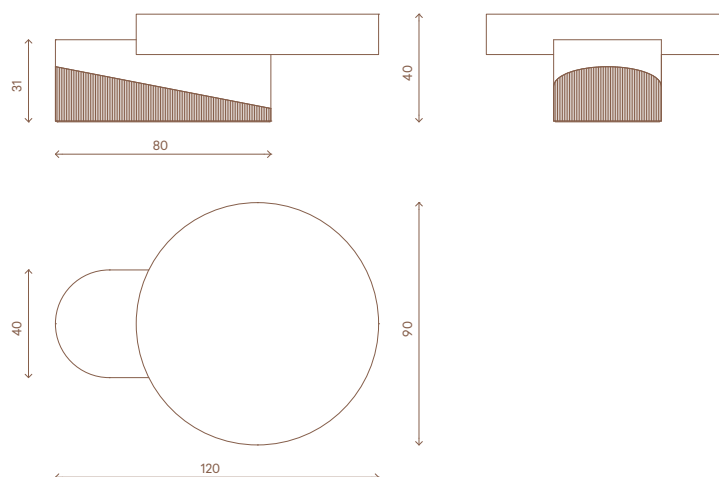

# STINGER

Tavolino  
Small table

Design  
Alessandro La Spada

Struttura portante in legno con rivestimento laterale in acciaio inox satinato e pelle, base in pelle con trapuntatura cannettata. Top con rivestimento in pelle. Opzione: gli elementi metallici sono disponibili satinati nella selezione finiture metalliche.

*Main structure in wood with side covered in satinized stainless steel and leather, base in leather with cannetè quilting. Top covered in leather. Option: metal parts available in the finishes included in the metal finishing selection.*

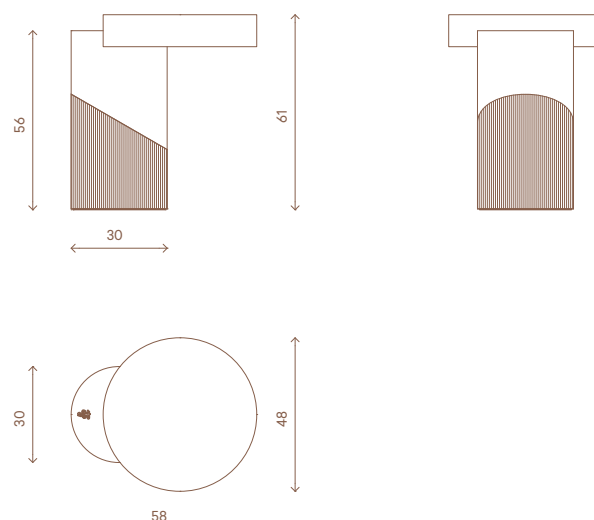

# SYLAR

Lampadario / Plafoniera  
Chandelier / Ceiling lamp

Design  
La Conca

Lampadario/plafoniera ovale in maglia di cristallo tessuta a mano formato da cinque drappi cascanti, incrociati a diverse altezze. Struttura portante in acciaio inox satinato, impianto a 20 luci G9, max 40W cad. Disponibile con impianto audio Bluetooth a 2 vie High-fidelity, potenza max 800W.

*Oval chandelier/ceiling lamp made of five crystal mesh hanging drapes, crossed at different heights. Support structure in brushed stainless steel, 20 G9 light system, max 40W each. Available with High-fidelity 2-way Bluetooth audio system, max power 800W.*

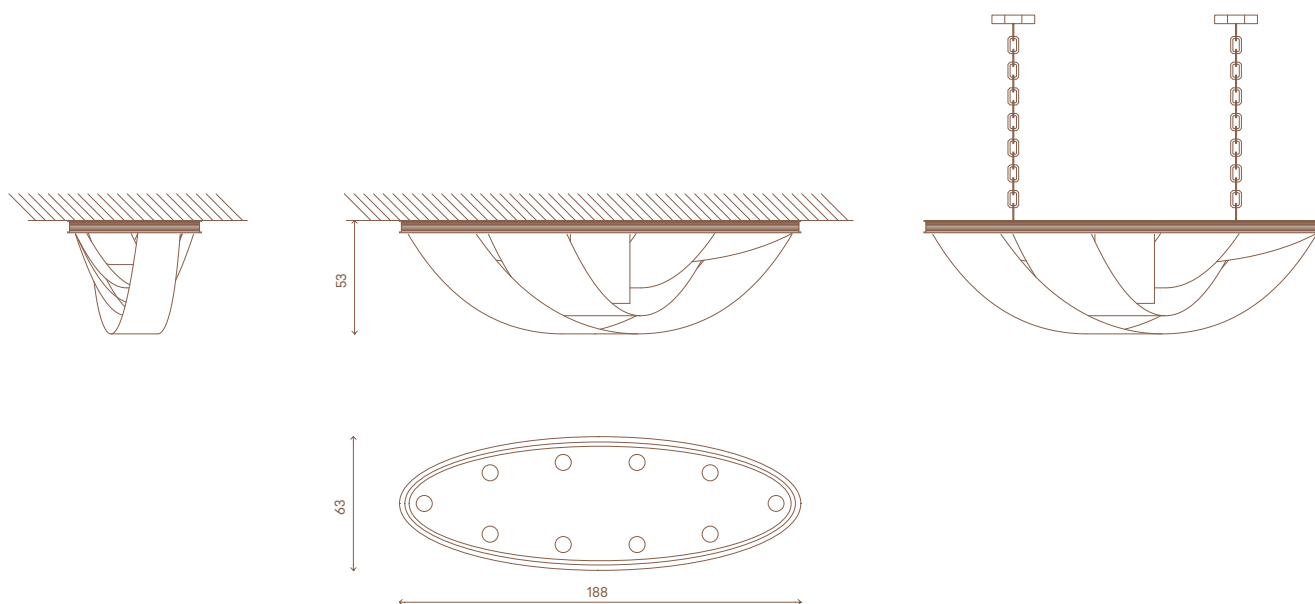

# TAGORA

Tappeto  
Carpet

Design  
La Conca

Tappeto taftato a mano in bamboo silk e lana New Zealand con lavorazione carving manuale. Backing in cotone.

*Hand-tufted carpet in bamboo silk and New Zealand wool with carving work. Cotton backing.*

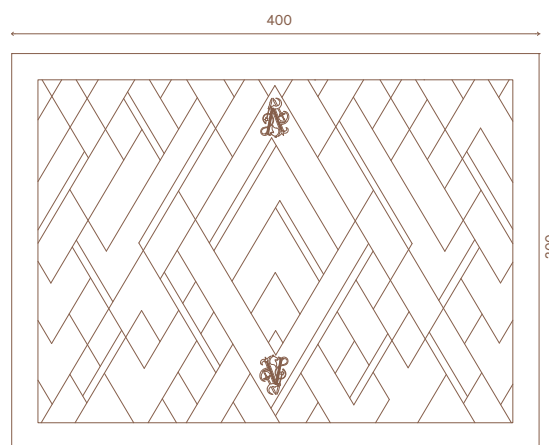

# TANYA

Poltroncina  
Armchair

Design  
Roberto Lazzeroni

Poltroncina monoscocca in poliuretano stampato a freddo con scocca interna in metallo. Rivestimento in pelle o tessuto; la parte esterna può essere rivestita in contrasto con la parte interna, divisa da un filetto in pelle, tappezzeria rifinita sul retro con cucitura manuale. Gambe costituite da una singola struttura in fusione di alluminio, con finitura antracite perlato e piedini in acciaio inox, disponibili nella selezione finiture metalliche.

*Armchair in cold-cured PU Foam molding with internal metal shell. Upholstery in leather or fabric; the external part can be covered in contrast with the internal part, divided by a leather thread, upholstery finished on the back with manual stitching. Legs in aluminium cast, with pearl anthracite matt finish and stainless steel feet, available in the metal finishing selection.*

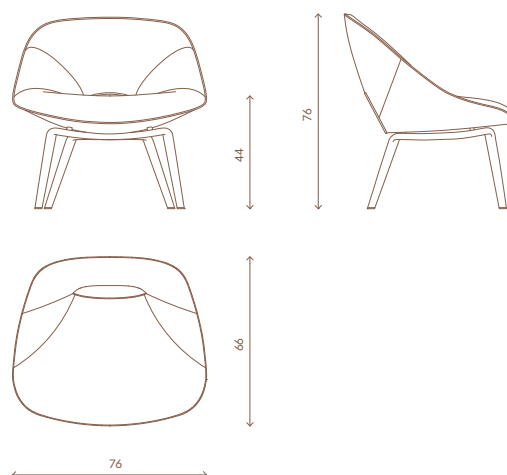

# TANYA

Sedia  
Chair

Design  
Roberto Lazzeroni

Poltroncina monoscocca in poliuretano stampato a freddo con scocca interna in metallo. Rivestimento in pelle o tessuto; la parte esterna può essere rivestita in contrasto con la parte interna, divisa da un filetto in pelle. Gambe costituite da una singola struttura in fusione di alluminio, con finitura antracite perlato opaco e piedini in acciaio inox, disponibili nella selezione finiture metalliche.

*Armchair in cold-cured PU Foam molding with internal metal shell. Upholstery in leather or fabric; the external part can be covered in contrast with the internal part, divided by a leather thread. Legs in aluminium cast, with pearl anthracite matt finish and stainless steel feet, available in the metal finishing selection.*

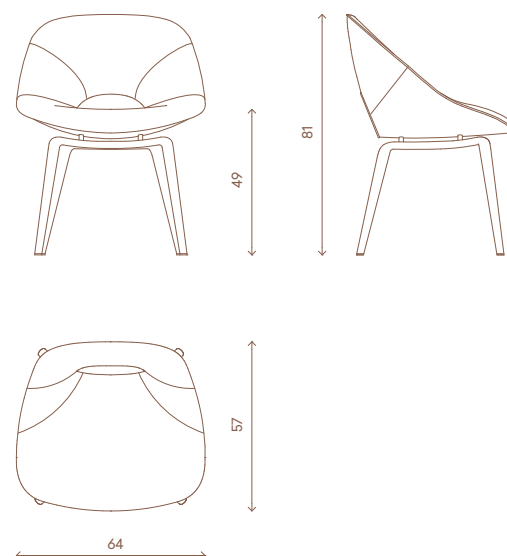

# TAREG

Specchio  
Mirror

Design  
Armando Bruno

Specchio in marmo e vetro accostati a filo, cornice in acciaio satinato. Porzione di marmo intarsiato Arabescato Vagli o Nero Marquina. Il sistema di attacco prevede diverse possibilità di orientamento. Le parti in acciaio sono disponibili nella selezione finiture metalliche satinato.

*Mirror in marble and glass, frame in thin satinized stainless steel. Portion of inlaid marble Arabescato Vagli or Nero Marquina. The attachment system provides various possibilities of orientation. Metal parts available in the satinized metal finishing selection.*

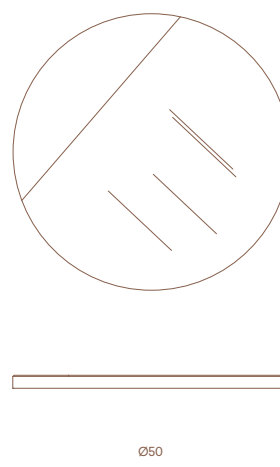

# TAYLOR DUAL

Divano, divano componibile  
Sofa, modular sofa

Design  
Giuseppe Viganò

Divano tappezzato in pelle o tessuto, con schienale e braccioli a doppio elemento con cuciture ribattute. Scocca interna in legno massello e multistrati, dotata di molleggio a cinghie elastiche. Cuscini di seduta in poliuretano, memory foam® e piuma. Cuscini di schienale e cuscini volanti in poliuretano e piuma. Scocca di seduta con base rigida e cuscini in appoggio. Base in legno rivestita in acciaio inox satinato. Le parti in metallo sono disponibili nella selezione finiture metalliche satinato. Gli elementi componibili offrono diverse possibilità di configurazione integrando gli elementi imbottiti Taylor con gli elementi in legno Agorà nella funzione di tavolini laterali o centrali.

*Upholstered sofa in leather or fabric with twin-element back and arms with riveted seams. Internal shell in solid wood and plywood, equipped with elastic belts springing. Seat cushions in polyurethane, memory foam® and feather. Back cushions and loose cushions in polyurethane and feather. Seat shell made of cushions on base. Wooden base covered in satin stainless steel. The metal parts are available in the satinized metal finishing selection. The modular elements offer different configuration possibilities by integrating the Taylor upholstered modular elements with Agorà wooden elements in the function of side or central tables.*

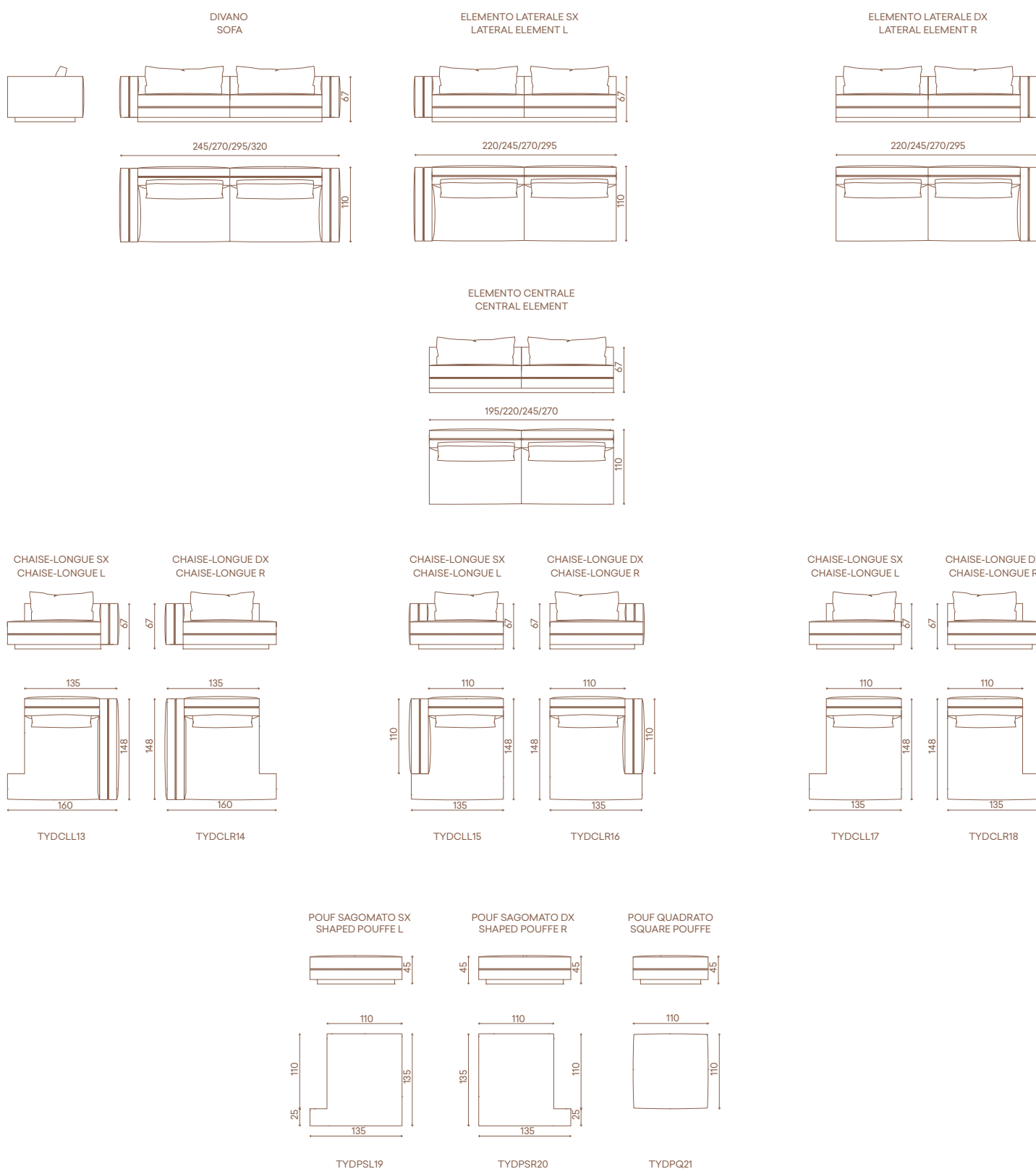

# TAYLOR STILL

Divano, divano componibile  
Sofa, modular sofa

Design  
Giuseppe Viganò

Divano tappezzato in pelle o tessuto, con schienale e braccioli a doppio elemento con cuciture ribattute. Scocca interna in legno massello e multistrati, dotata di molleggio a cinghie elastiche. Cuscini di seduta in poliuretano, memory foam® e piuma. Cuscini di schienale e cuscini volanti in poliuretano e piuma. Scocca di seduta a singolo elemento. Base in legno rivestita in acciaio inox satinato. Le parti in metallo sono disponibili nella selezione finiture metalliche. Gli elementi componibili offrono diverse possibilità di configurazione integrando gli elementi imbottiti Taylor con gli elementi in legno Agorà nella funzione di tavolini laterali o centrali.

*Upholstered sofa in leather or fabric with twin-element back and arms with riveted seams. Internal shell in solid wood and plywood, equipped with elastic belts springing. Seat cushions in polyurethane, memory foam® and feather. Back cushions and loose cushions in polyurethane and feather. Seat shell in one piece integrated with the structure. Wooden base covered in satin stainless steel. The metal parts are available in the metal finishing selection. The modular elements offer different configuration possibilities by integrating the Taylor upholstered modular elements with Agorà wooden elements in the function of side or central tables.*

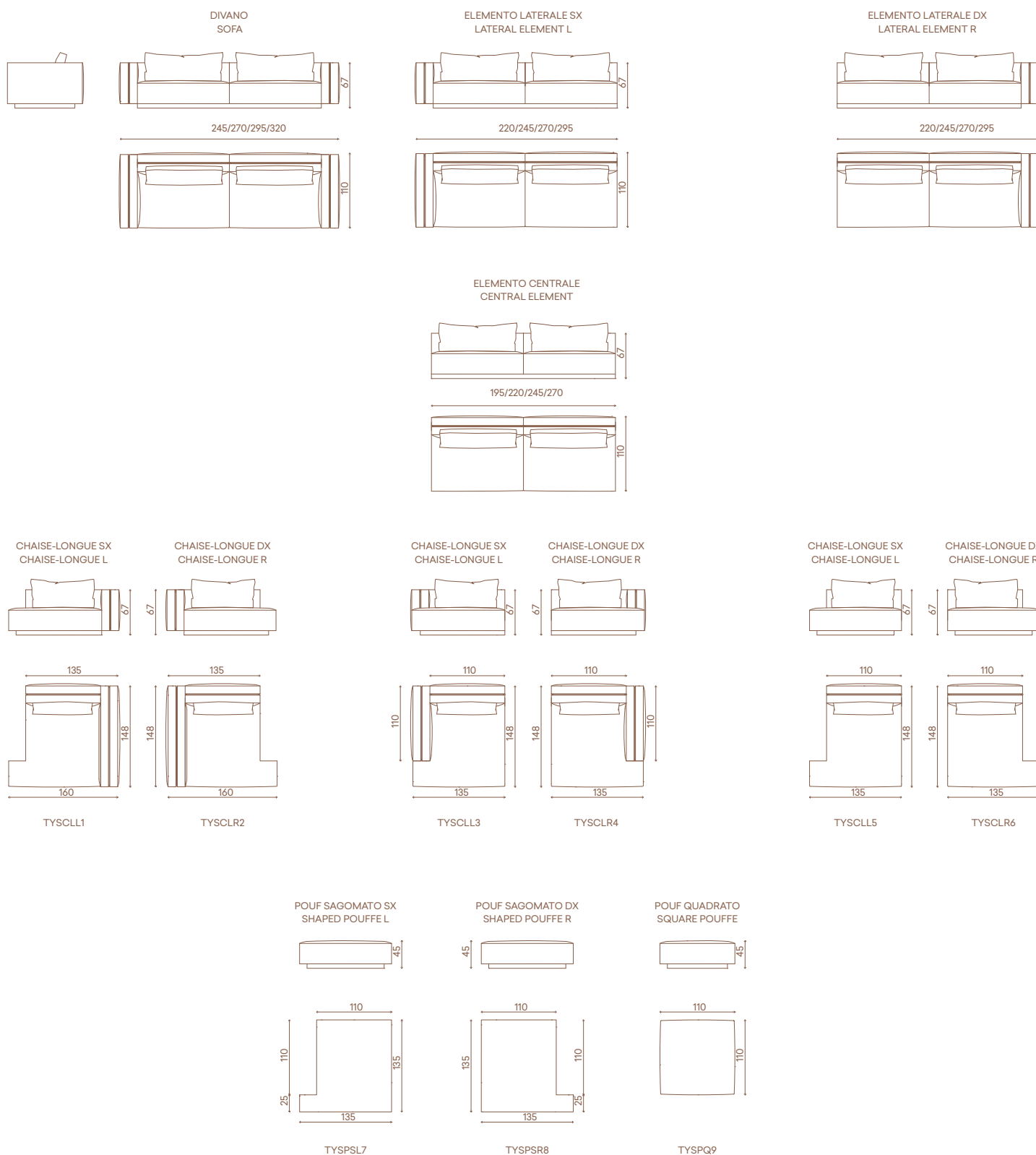

# TYRION

Tappeto  
Carpet

Design  
La Conca

Tappeto taftato a mano in bamboo silk e lana New Zealand con lavorazione carving manuale. Backing in cotone.

*Hand-tufted carpet in bamboo silk and New Zealand wool with carving work. Cotton backing.*

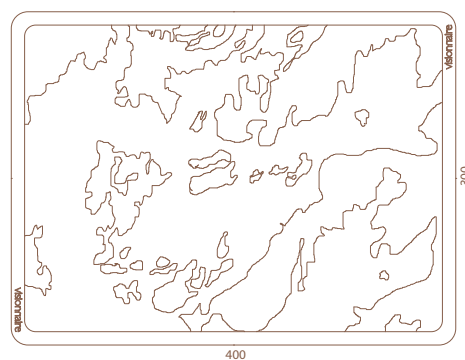

# TEA PARTY

Consolle  
Console

Design  
Alessandro La Spada

Struttura portante in acciaio inox satinato, top in doghe di legno massello tinto nelle finiture "MAS", piatto decorativo concavo in marmo Carrara lavorato a incastro. Nelle doghe sono incastonate due targhette satiniate con logo Visionnaire. Gli elementi metallici sono disponibili nella selezione finiture metalliche satiniate.

*Main structure in satinized stainless steel, top in solid wood stripes, concave decorative plate in marble, with interlocking manufacture. Two satinized plates with Visionnaire logo are embedded in the wood stripes. Metal parts available in the satinized metal finishing selection.*

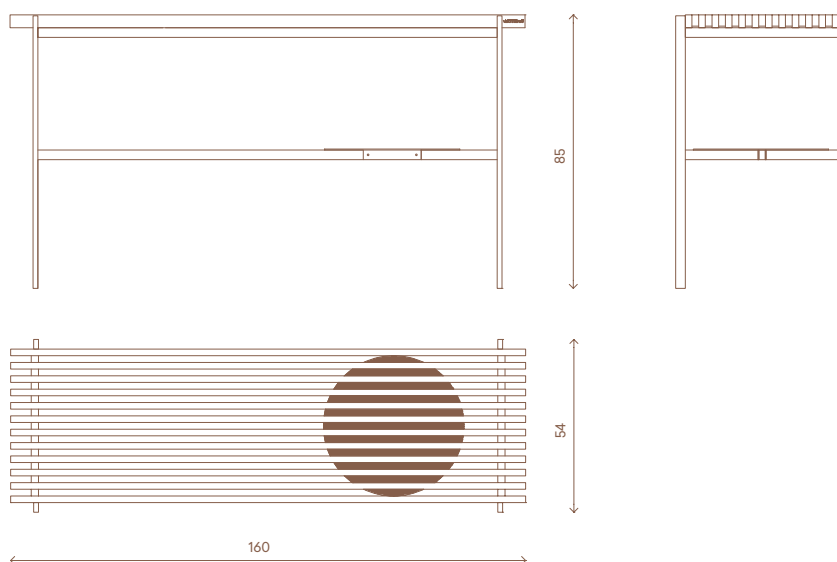

# THAMOS

Mobile con ante  
Cabinet

Design  
Alessandro La Spada

Mobile contenitore con quattro ante, struttura in legno con fianchi concavi, top e ante in essenza con finitura manuale lucida 100 gloss. Cornice interna di fianchi e top in acciaio inox lucido curvato verso l'interno. Gli interni del mobile sono laccati in tinta RAL con finitura opaca, con cassetti interni parzialmente a vista anche con ante chiuse. Disponibile con illuminazione interna a LED sotto-top. Le parti in metallo sono disponibili nella selezione finiture metalliche, le parti in legno sono disponibili nelle finiture selezione essenze.

*Cabinet with four doors, wooden frame with concave sides, veneered top and doors with 100 gloss handmade finishing. Internal frame of sides and top in polished stainless steel bent inwards. Interiors laquered in RAL colour with a matte finish, with visible internal drawers even with closed doors. Available with inside LED light under the top. Metal parts available in the metal finishing selection, wooden parts available in the veneer selection finishings.*

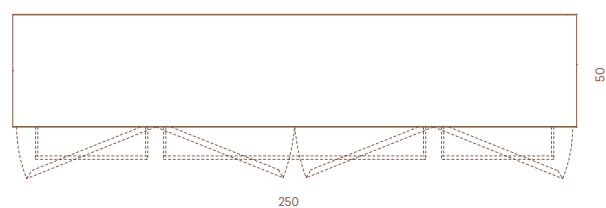
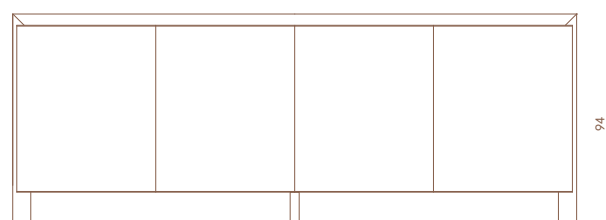

# WESTLEY

## Mobile trucco Make-up desk

Design  
Steve Leung

Mobile trucco costituito da una cassettera e top in cristallo da 16 mm. Struttura in legno multistrati e MDF con frontali cassetti rivestiti in essenza e interni laccati (colori RAL). Top e fianco esterno della cassettera rivestiti in pelle intrecciata con bordi lisci. Zoccolo e bordature cassetti in acciaio inox satinato. Top in vetro temperato (extra chiaro/bronzo/fumé), gamba in legno rivestita in pelle con puntalini in acciaio inox satinato. I frontali dei cassetti ed il rivestimento lato interno sono disponibili nelle finiture selezione essenze. Le parti in metallo sono disponibili nella selezione finiture metalliche satinato. In abbinamento a specchiera luminosa WESTLEY.

Vanity unit with drawer unit and top in crystal 16 mm. Structure in plywood and MDF with front drawers covered in veneer and lacquered internal parts (RAL colours). Top and external side of the drawer unit covered with woven leather with smooth edges. Plinth and drawers borders in satinized stainless steel. Top in tempered glass (extra clear/bronze/smoked), wooden leg covered in leather with tips in satinized stainless steel. The available finishes for the front drawers and the internal side are included in the veneer selection finishings. Metal parts available in the satinized metal finishing selection. In combination with WESTLEY mirror with lighting.

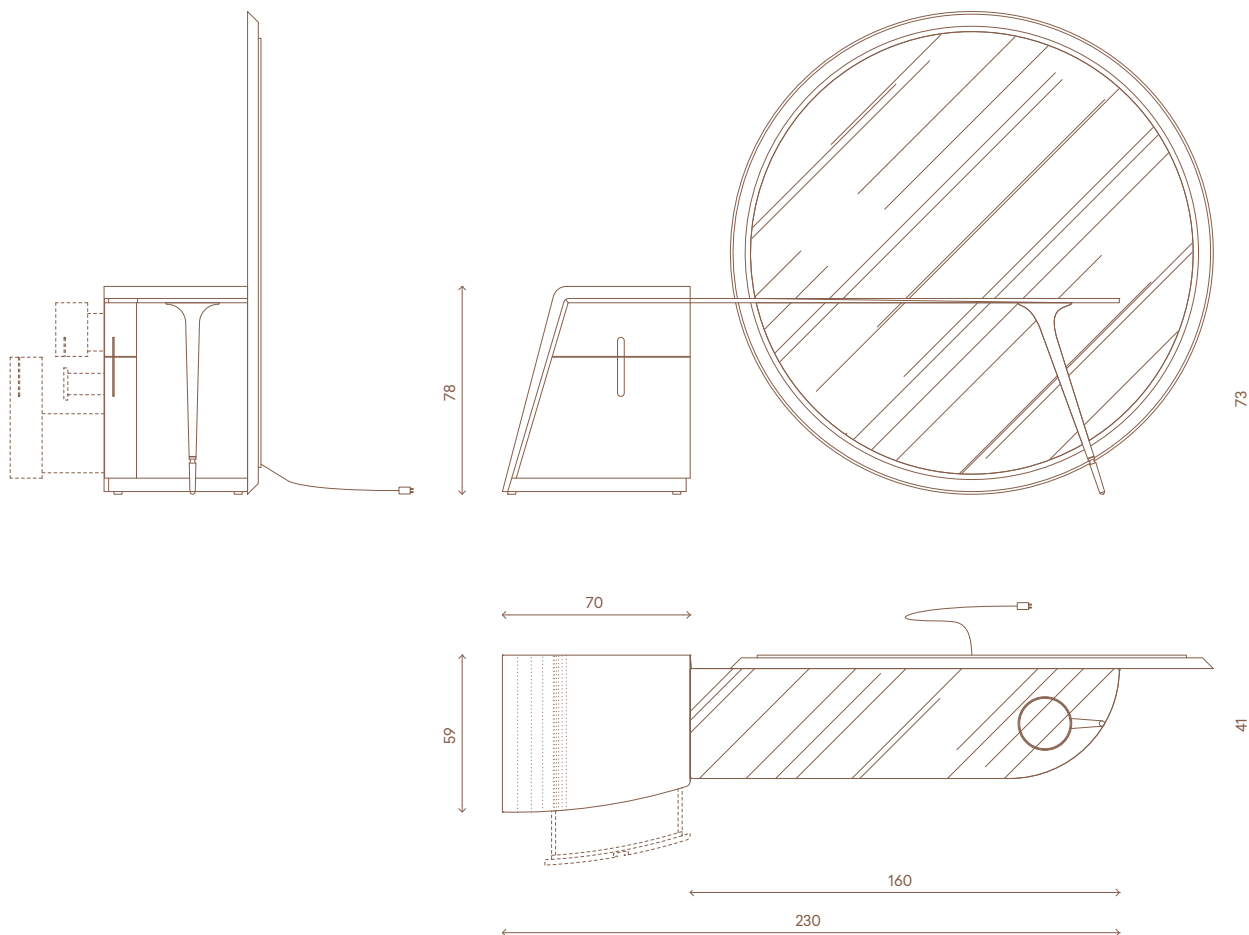

# WESTLEY

## Specchio Mirror

Design  
Steve Leung

Cornice in acciaio inox satinato con bordo conico. Illuminazione perimetrale a luci LED con accensione a sfioramento. Le parti in metallo sono disponibili nella selezione finiture metalliche satinato.

Frame in satinized stainless steel with conical border. LED lighting on perimeter with touch sensor. Metal parts available in the satinized metal finishing selection.

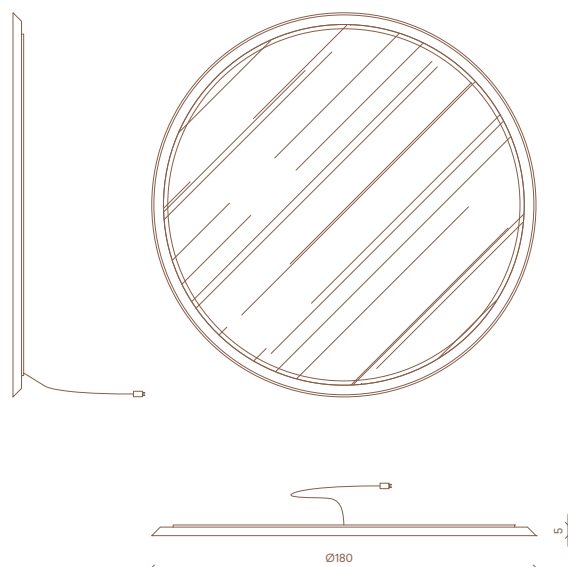

# WUNJO

**Poltrona**  
**Armchair**

**Design**  
Steve Leung

Struttura in legno multistrato e massello, imbottitura in poliuretano espanso a densità differenziate, Memory Foam® e fibra acrilica, tappezzeria di schienale con disegno a losanghe trapuntate. Cuscino reggi-reni in piuma, piedi anteriori in alluminio tornito finitura cromo oppure oro o bronzo, posteriori rivestiti in pelle o tessuto. Opzione: inserto decorativo nel bracciolo in pietra semipreziosa o in radica/essenza

Structure in plywood and in solid wood, polyurethane foam in different densities Memory Foam® and acrylic fibre padding, backrest upholstery with captonné rhombus pattern and seat cushion with light quilting. Back cushion in goose down, front feet in turned aluminium in chromed/golden/bronzed finishing and rear feet covered with fabric or leather. Option: decorative insert in the armrest in semi-precious stone or briar wood/veneer

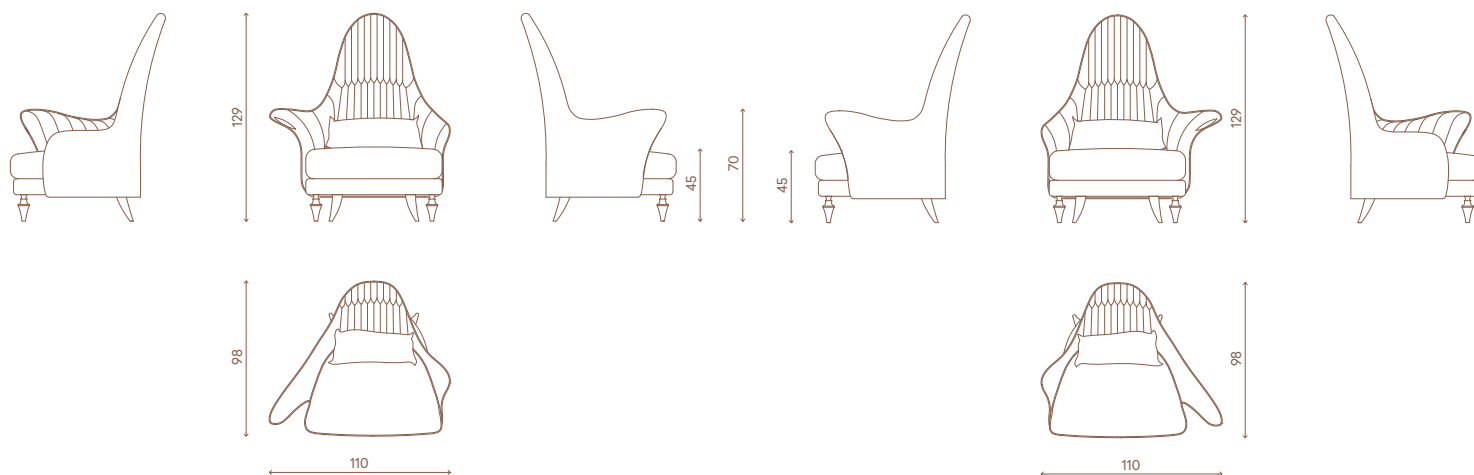

# XAVIER MASTER&BOARD

**Divano, divano componibile**  
**Sofa, modular sofa**

**Design**  
Mauro Lipparini

Divano tappezzato in pelle o tessuto, con base a piattaforma e schienale e braccioli trapezoidali imbottiti. scocca interna in legno massello e multistrati di pioppo e faggio. Cuscini di seduta in poliuretano, memory foam® e piuma. Cuscini di schienale con lavorazione "chevron" in poliuretano e piuma. Disponibile anche con bracciolo e schienale in versione "board" in legno rivestito in pelle, tessuto o pelle intrecciata; elementi strutturali e decorativi in ottone massiccio satinato con placche incise con logo Visionnaire. Cuscini schienale in diverse misure in poliuretano e piuma. Gli elementi laterali "board" sono disponibili anche con piattaforma estesa "extension" sotto il bracciolo di +40 cm.

Upholstered leather or fabric sofa, with platform base and backrest and trapezoidal upholstered armrests. inner shell in solid wood and poplar and beech plywood. Seat cushions in polyurethane, memory foam® and feather. Back cushions with "chevron" processing in polyurethane and feather. Also available with armrest and backrest in the "board" version in wood upholstered in leather, fabric or woven leather; structural and decorative elements in solid satin brass with engraved plaques with Visionnaire logo. Backrest cushions in different sizes in polyurethane and feather. The side "board" elements are also available with optional "extension" platform under the armrest of +40 cm.

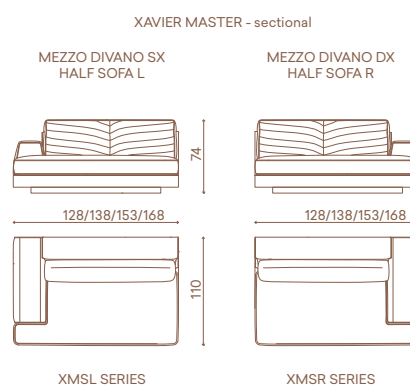
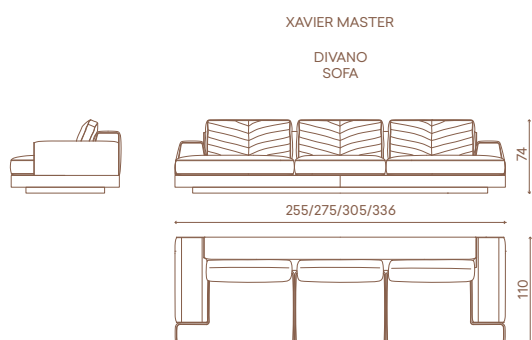



ELEMENTO LATERALE SX  
LATERAL ELEMENT L

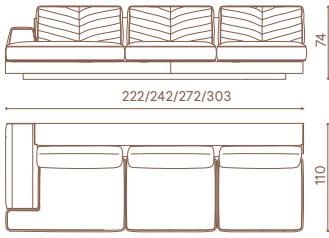

XMSL SERIES

ELEMENTO LATERALE DX  
LATERAL ELEMENT R

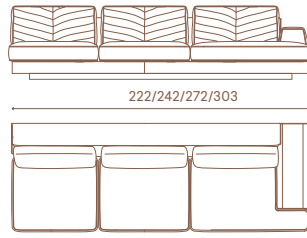

XMSR SERIES

DORMEUSE SX  
DORMEUSE L

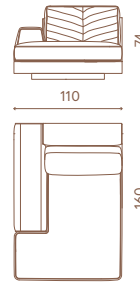

XMSDL48

DORMEUSE DX  
DORMEUSE R

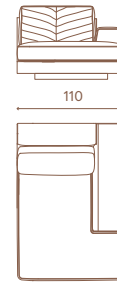

XMSDR49

ELEMENT ANGOLARE  
CORNER ELEMENT

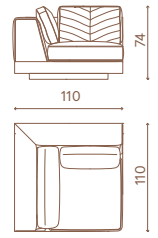

XMSA26

XAVIER BOARD - sectional

MEZZO DIVANO SX  
HALF SOFA L

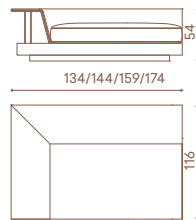

XBDL SERIES

MEZZO DIVANO DX  
HALF SOFA R

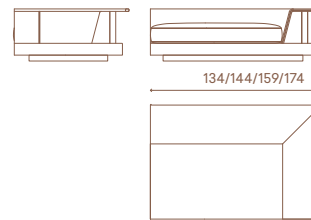

XBDR SERIES

ELEMENTO LATERALE SX  
LATERAL ELEMENT L

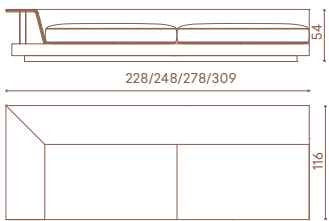

XBSLL SERIES

ELEMENTO LATERALE DX  
LATERAL ELEMENT R

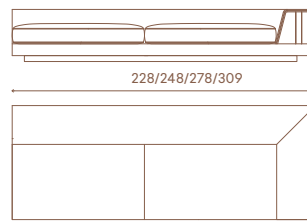

XBSLR SERIES

DORMEUSE SX  
DORMEUSE L

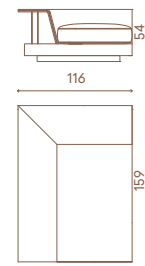

XBDDL30

DORMEUSE DX  
DORMEUSE R

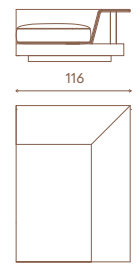

XBDDR31

XAVIER BOARD  
sectional with extension

ELEMENTO LATERALE SX  
LATERAL ELEMENT L

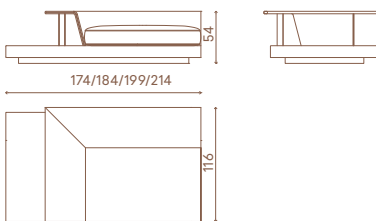

XBDEXL SERIES

ELEMENTO LATERALE DX  
LATERAL ELEMENT R

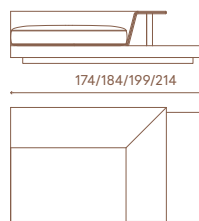

XBDEXR SERIES

ELEMENTO LATERALE SX  
LATERAL ELEMENT L

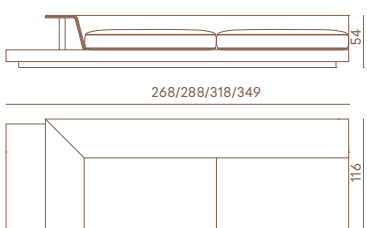

XBSEXL SERIES

ELEMENTO LATERALE DX  
LATERAL ELEMENT R

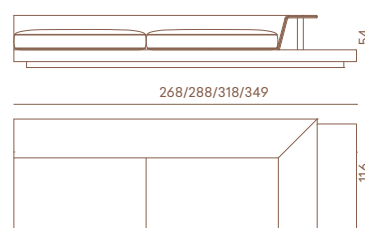

XBSEXR SERIES

CUSCINI VOLANTI  
LOOSE CUSHIONS

30x30

40x40



45x45

48x48



53x53



---

# AGGREGATO N10

Design  
CaCO<sub>3</sub>

Malta, ferro.

*Mortar, iron frame.*



---

# ALVEOLIZZAZIONE N7

Design  
CaCO<sub>3</sub>

Gesso e malta su popolit.

*Plaster and mortar on popolit.*



---

# ARBOR

Design  
Michele Astolfi

Opera su fondo in plexi con lavorazione di cristalli Swarovski.

*Plexiglass base with Swarovski crystals processing.*



---

# BAMBÙ

Design  
Michele Astolfi

Opera su fondo in plexi con lavorazione in vetro artistico.

*Plexiglass base with artistic glass.*

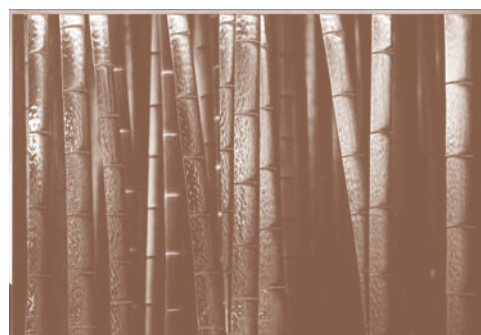

---

# BEETLE/A-B-C-D-E-F

Design  
Michele Astolfi

Opera su fondo in plexi con lavorazione in legno fossile Abonos™ e cristalli Swarovski.

*Plexiglass base with fossil wood Abonos™ inserts and Swarovski crystals processing.*



---

# BIRCHES

**Design**  
Michele Astolfi

Opera su fondo in plexi con lavorazione in vetro.

*Plexiglass base with glass processing.*



---

# CATTEDRALE N41

**Design**  
CaCO3

Vetro cattedrale (verde), ossido minerale e malta, ferro.

*Glass (green), mineral oxide and mortar, iron frame.*



---

# CATTEDRALE/N57-58-59

**Design**  
CaCO3

Vetro cattedrale (bordeaux), ossido minerale e malta, ferro.

Vetro cattedrale (grigio), ossido minerale e malta, ferro.

Vetro cattedrale (rosa), ossido minerale e malta, ferro.

*Glass (bordeaux), mineral oxide and mortar, iron frame.*

*Glass (gray), mineral oxide and mortar, iron frame.*

*Glass (pink), mineral oxide and mortar, iron frame.*

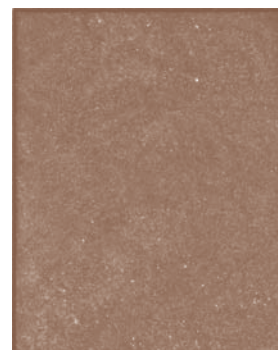

---

# DANAUS

**Design**  
Michele Astolfi

Opera su fondo in plexi con lavorazione in legno fossile Abonos™, madreperla e vetro artistico.

*Plexiglass base with fossil wood Abonos™, mother of pearl inserts and artistic glass.*



---

# FLAMINGOS

**Design**  
Michele Astolfi

Opera su fondo in plexi con lavorazione in vetro artistico e cristalli Swarovski.

*Plexiglass base with artistic glass and Swarovski crystals processing.*



---

# KALLIMA

Design  
Michele Astolfi

Opera su fondo in plexi con lavorazione in legno fossile Abonos™ e vetro artistico.

*Plexiglass base with fossil wood Abonos™ inserts and artistic glass.*



---

# KOI CARP

Design  
Michele Astolfi

Opera su fondo in plexi con lavorazione in vetro artistico e cristalli Swarovski.

*Plexiglass base with artistic glass and Swarovski crystals processing.*



---

# MOVIMENTO N21

Design  
CaCO3

Calcare nero, ossido minerale e malta, ferro.

*Black limestone, mineral oxide and mortar, iron frame.*

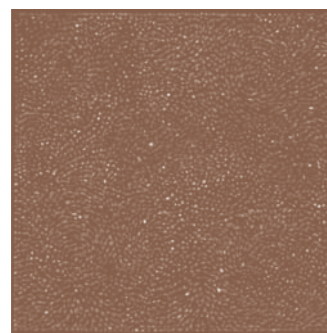

---

# MOVIMENTO N108

Design  
CaCO3

Pasta di vetro con foglia d'oro bianco, ossido minerale e malta, ferro.

*Glass paste with white golden leaf, mortar, mineral oxide, iron frame.*

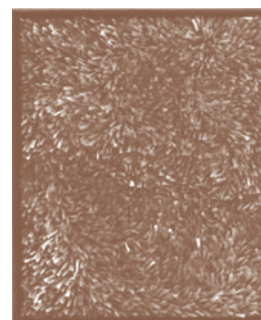

---

# MOVIMENTO N132

Design  
CaCO3

Pasta di vetro, ossido minerale e malta.

*Glass paste, mineral oxide and mortar.*

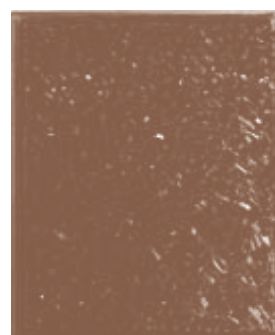

---

## SENZA TITOLO - UNTITLED

**Design**  
Gianni Asdrubali

Lastra in gres dipinta a mano.  
Disponibile in colore nero (Ral 9005) o blu (Ral 5008).

*Hand painted porcelain slab.  
Available in black (Ral 9005) or blue color (Ral 5008).*

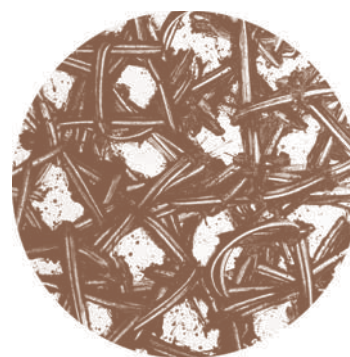

---

## SENZA TITOLO - UNTITLED

**Design**  
Maurizio Cannavacciuolo

Lastra in gres con decoro digitale e intervento dipinto a mano  
in oro zecchino in terza cottura.

*Porcelain slab with digital decoration and hand-painted  
in pure gold in third ring.*



---

## SOFFIO N15

**Design**  
CaCO3

Calcare, malta e stucco, ferro.

*Limestone, mortar and stucco, iron frame.*



---

## SOFFIO N16

**Design**  
CaCO3

Pasta di vetro con foglia d'oro bianco e malta, ferro.

*Glass paste with white golden leaf, mineral oxide and mortar, iron frame.*



---

## SOFFIO N20

**Design**  
CaCO3

Glass, mineral oxide and mortar, iron frame.

*Glass (gray), mineral oxide and mortar, iron frame.*

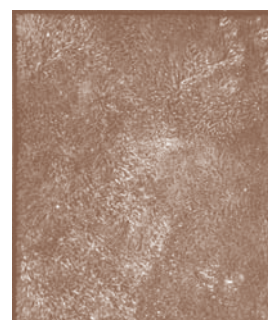

---

# ABSTRACT, CLAN, PAISLEY, TARTAN, TWEED, PLAID

Plaid  
*Plaid*

Design  
La Conca

Mezzero a doppia stampa con bordo in ecopelle,  
tessuto 50% Alpaca, 50% Lana, peso 620 gr. ml.

*Double printed "mezzero" with ecoleather edge,  
50% Alpaca, 50% Wool fabric, weight 620 gr. ml.*

**ABSTRACT** cm 243x135,  
**CLAN** cm 240x150,  
**PAISLEY** cm 250x148,  
**TARTAN** cm 230x140,  
**TWEED** cm 250x150.

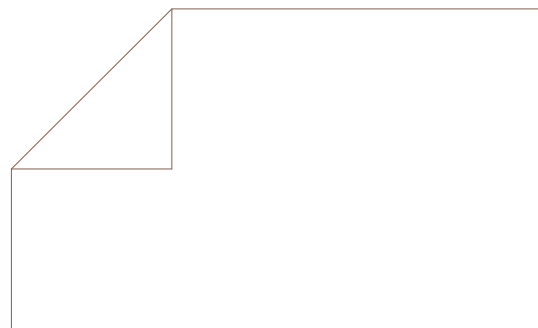

---

## AIRONI

Vaso Veronese  
*Vase Veronese*

Design  
La Conca

Vaso fatto a mano smaltato opaco colore tortora con soggetti artistici  
"aironi" smaltati argento.

*Vase in matt tortora enamelled with silver enamelled herons.*

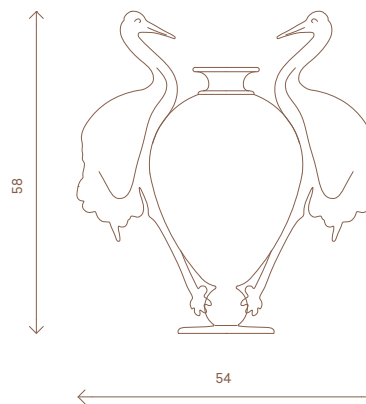

---

## ALI DISCHIUSE

Vaso Veronese  
*Vase Veronese*

Design  
La Conca

Vaso fatto a mano smaltato madreperla con soggetti artistici "ali" smaltate  
argento.

*Vase in mother of pearl enamelled with silver enamelled wings.*

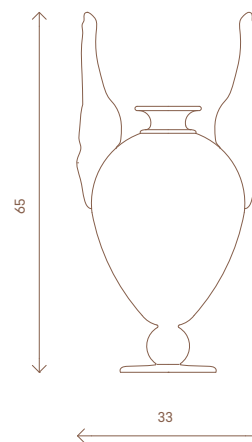

---

## ANAEL

Scrigno  
*Chest*

Design  
La Conca

Vaso fatto a mano smaltato madreperla con soggetti artistici "ali" smaltate  
argento.

*Vase in polished army green with golden enamelled handles and silver  
enamelled sculpture.*

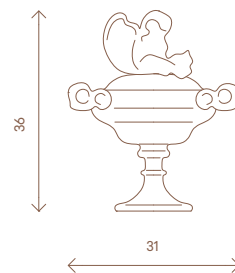

# CHERON

Set di posate  
Cutlery set

Design  
La Conca

Set di posate nere in acciaio inox con punzonatura stemma araldico Visionnaire.

*Stainless steel cutlery with punching Visionnaire coat of arms and silver enamelled sculpture.*

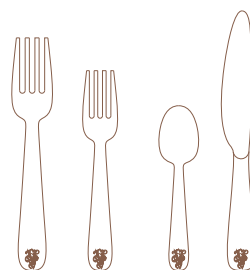

# HORNY

Vaso porta-candela  
Candle-holder vase

Design  
La Conca

Vaso porta-candela fatto a mano, smaltato lucido colore blu scuro con scultura in platino. Peso della cera Kg. 1,6.

*Vase and cover in polished dark blue, sculpture in platinum. Scented wax, weight Kg. 1,60.*

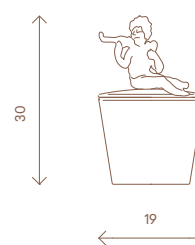

# MEZZARO GLAM

Glam plaid  
Glam plaid

Design  
La Conca

Mezzero in tessuto jacquard 70% lana vergine, 15% seta, 15% modal, peso 320 gr.

*"Mezzero" in jacquard fabric 70% virgin wool, 15% silk, 15% modal, weight 320 gr.*

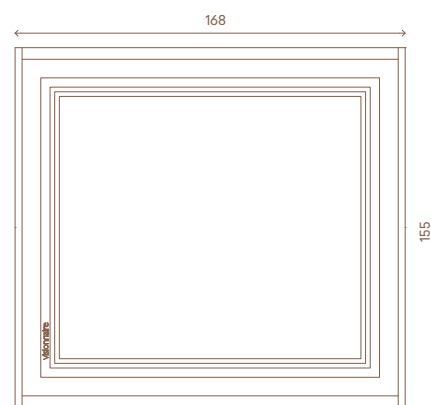

# MORAX

Vaso porta-candela  
Candle-holder vase

Design  
La Conca

Vaso porta-candela fatto a mano, smaltato lucido nickel nero con scultura nickel nero e dettagli oro. Peso della cera Kg. 1,6.

*Vase and cover in polished black nickel, sculpture in black nickel with golden details. Scented wax, weight Kg. 1,60.*

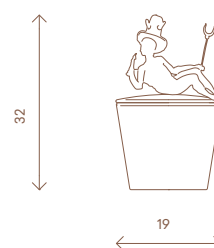

---

# OPHIDIA

Scrigno  
Chest

Design  
La Conca

Scrigno smaltato grigio/blu con soggetto artistico satinato opaco tortora.

*Vase in enamelled blue/grey with satinized matt tortora enamelled sculpture.*

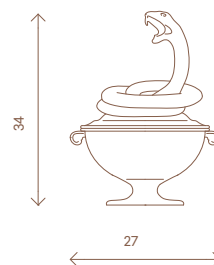

---

# RAGUEL

Scrigno  
Chest

Design  
La Conca

Scrigno smaltato argento con soggetto artistico smaltato oro.

*Vase in silver enamelled with matt golden enamelled sculpture and profiles.*

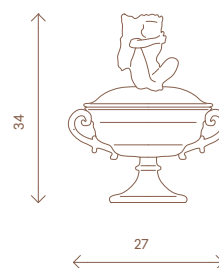

---

# REVEL

Vaso porta-candela  
Candle-holder vase

Design  
La Conca

Vaso porta-candela fatto a mano, smaltato madreperla verde con scultura argento. Peso della cera Kg. 1,6.

*Vase and cover in polished green mother-of-pearl with sculpture in silver. Scented wax, weight Kg. 1,60.*

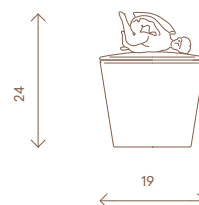

---

# SERPENTE

Scultura  
Sculpture

Design  
La Conca

Scultura in ceramica nickel nera.

*Black nikel ceramic.*

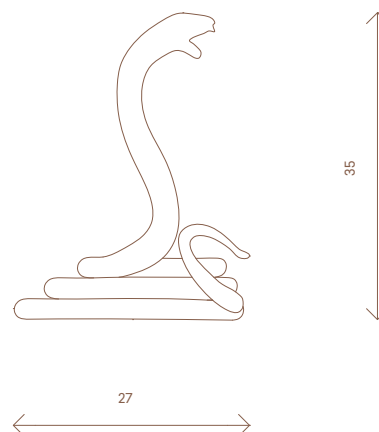



# TARTARUGA

Vaso Veronese  
Vase Veronese

Design  
La Conca

Vaso fatto a mano smaltato opaco colore verde militare con soggetto artistico "tartaruga" smaltato argento.

*Vase in matt army green enamelled with silver enamelled turtle.*

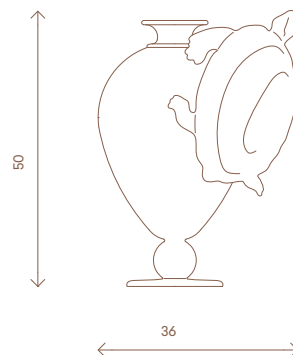

# UMBERTO

Piatto  
Plate

Design  
La Conca

Piatto grande e piccolo, disponibili nei colori grigio marmorizzato o verde marmorizzato, con inserto charm.

*Plates available in marmored grey or marmored green colour, with charms application.*

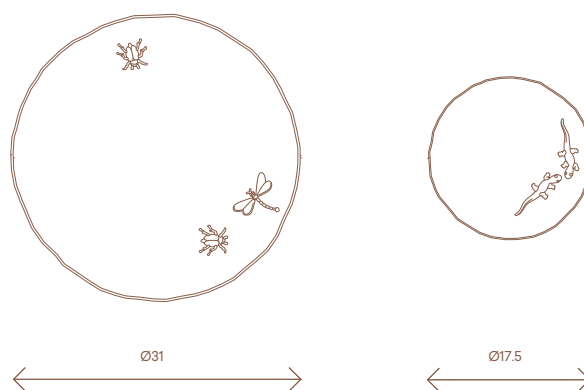

# UMBERTO

Segnaposto  
Placeholder

Design  
La Conca

Segnaposto, disponibile con inserto charm ape o libellula.

*Placeholder with charms application. Availble with bee charm or dragonfly charm.*

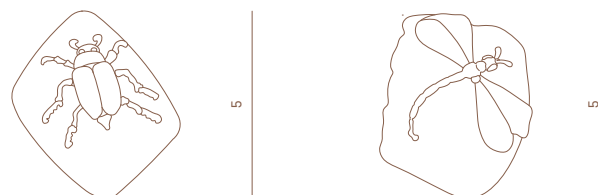

# URIEL

Scrigno  
Chest

Design  
La Conca

Scrigno smaltato rame con maniglie e soggetto artistico smaltato argento.

*Vase in matt copper enamelled with silver enamelled handles and sculpture.*

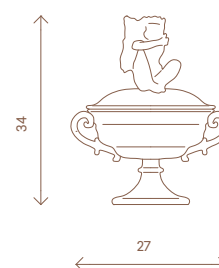

Produced by  
©IPE SRL  
ALL RIGHTS RESERVED

*Visionnaire Logo, catalogue and advertising images are sole propriety of IPE srl, henceforth any use of the logo or adaptation of images is strictly forbidden without IPE srl prior approval; nonetheless, in any case the images must be used in such a way that there is no reasonable doubt that those belong to IPE srl and refer to IPE srl products.  
No part of this publication can be reproduced or transmitted in any form or by any means, both electronic or mechanical, including photocopying and recording, or via any information storage and retrieval system, without written permission of the publisher.*

Print Made in Italy, July 2018 by Euroteam

Art Director:  
Eleonore Cavalli

Photo credits:  
Max Zambelli

Styling:  
Beatrice Rossetti Studio

Graphic Design:  
Alessandro Costariol

Thanks to:  
Alessio Sarri, Bosa, Budri, Chung T-Jong, Decormarmi, Gianpaolo Venier, Isaac Monte', Katriina Nuutinen, Matteo Pugliese, Michela Cattai, Lucia Massari courtesy Swing Design Gallery, Venini.

Tutti i colori dei rivestimenti, pelli e tessuti, delle lacche, dei vetri, dei marmi e dei tappeti non possono essere considerati come riferimento colore. Le misure dei prodotti possono subire delle modifiche rispetto alle indicazioni del catalogo.

*All colors of leather or fabric's covers, lacquered wood, mirrors, marbles and carpets can't be considered as color references.  
The dimensions of products are subject to change according to the instructions of the catalog.*

I.P.E. S.r.l.  
Via Mattei 1 – 40069 Zola Predosa (Bo) Italy  
tel. +39 051 6186311 – fax +39 051 6186310  
[www.ipe-cavalli.it](http://www.ipe-cavalli.it)  
[www.visionnaire-home.it](http://www.visionnaire-home.it)  
[ipe@ipe.it](mailto:ipe@ipe.it)





HOME PHILOSOPHY  
visionnaire

THE ORIGINAL.  
CONCEIVED AND CRAFTED IN ITALY.